

V1.3-2026-06-08

# Residential All-In-One Energy Storage System

## ESA 5-30kW

GW5.1-BAT-D-G20

GW8.3-BAT-D-G20

GW5.1-BAT-D-G21

GW8.3-BAT-D-G21

GW6.0-BAT-D-G20

GW9.0-BAT-D-G20

## Solutions Manual

**GOODWE**

# Copyright Statement

## Copyright Statement

**Copyright© GoodWe Technologies Co., Ltd. 2026. All rights reserved.**

Without the authorization of GoodWe Technologies Co., Ltd., no part of this manual may be reproduced, distributed, or uploaded to third-party platforms such as public networks in any form.

## **Trademark Authorization**

**GOODWE** and other GOODWE trademarks used in this manual are owned by GoodWe Technologies Co., Ltd. All other trademarks or registered trademarks mentioned in this manual belong to their respective owners.

## **NOTICE**

Due to product version upgrades or other reasons, the content of this document is updated periodically. Unless otherwise agreed, the content of this document cannot replace the safety precautions on the product label. All descriptions in the document are for guidance only.

# About This Manual

## Overview

This document primarily introduces the product information, installation wiring, configuration and commissioning, troubleshooting, and maintenance content for the energy storage system composed of inverters, Battery system, and smart meters. Please read this manual carefully before installing and using the product to understand the product safety information and familiarize yourself with the product's functions and features. The document may be updated periodically; please obtain the latest version of the materials and more product information from the official website.



## Applicable Model

The energy storage system includes the following products:

Product Type	Product Information	Description
Inverter	GW5K-ETA-G20 GW6K-ETA-G20 GW8K-ETA-G20 GW9.999K-ETA-G20 GW10K-ETA-G20 GW12K-ETA-G20 GW15K-ETA-G20 GW20K-ETA-G20 GW25K-ETA-G20 GW29.999K-ETA-G20 GW30K-ETA-G20 GW5K-BTA-G20 GW6K-BTA-G20 GW8K-BTA-G20 GW9.999K-BTA-G20 GW10K-BTA-G20 GW12K-BTA-G20 GW15K-BTA-G20 GW20K-BTA-G20 GW25K-BTA-G20 GW29.999K-BTA-G20 GW30K-BTA-G20	Nominal output power: 5kW-30kW
Battery system	GW5.1-BAT-D-G20 GW5.1-BAT-D-G21	Rated energy 5.12kWh
	GW8.3-BAT-D-G20 GW8.3-BAT-D-G21	Rated energy 8.32kWh
	GW6.0-BAT-D-G20	Rated energy 6kWh

Product Type	Product Information	Description
	GW9.0-BAT-D-G20	Rated energy 9kWh
Meter	GMK330 GM330	Monitoring module in the energy storage system, capable of detecting operational voltage, current, and other information within the system.
smart dongle	WiFi/LAN Kit-20	Uploads system operational information to the monitoring platform via WiFi or LAN signals.
	4G Kit-G20	Uploads system operational information to the monitoring platform via 4G.

## Symbol Definition

 <b>DANGER</b>
Indicates a highly potential danger that, if not avoided, will result in death or serious injury.
 <b>WARNING</b>
Indicates a moderately potential danger that, if not avoided, may result in death or serious injury.
 <b>CAUTION</b>
Indicates a low potential danger that, if not avoided, may result in moderate or minor injury.
<b>NOTICE</b>
Emphasizes and supplements the content, and may also provide tips or tricks for optimizing product use, helping you solve a problem or save your time.

## Table of Contents

1 Safety Precautions	10
1.1 General Safety	10
1.2 personnel requirements	11
1.3 System Safety	12
1.3.1 PV String Safety	14
1.3.2 Inverter Safety	15
1.3.3 Battery Safety	16
1.3.4 Smart Meter Safety	19
1.4 Safety Symbols and Certification Marks	19
1.5 EU Declaration of Conformity	21
1.5.1 Equipment with Wireless Communication Modules	21
1.5.2 Equipment without Wireless Communication Modules (Except Battery)	21
1.5.3 Battery	22
2 System Introduction	23
2.1 System Overview	23
2.2 Product Overview	39
2.2.1 Residential All-in-one System	39
2.2.2 Smart Meter	46
2.2.3 Smart Dongle	47
2.3 Supported Grid Types	48
2.4 System Working Mode	48

2.5 Features	58
3 Check and Storage	63
3.1 Check Before Receiving	63
3.2 deliverables	63
3.2.1 Inverter Deliverables	63
3.2.2 Batteries Deliverables	67
3.2.2.1 Expansion Cluster Base Deliverables	68
3.2.2.2 Floor-Mounted Standoff Bracket	70
3.2.3 Smart Meter Deliverables GM330&GMK330	70
3.2.3.1 Accessory List	70
3.3 Storage	71
4 Installation	74
4.1 Installation Requirements	74
4.1.1 Installation Environment Requirements	74
4.1.2 Installation Space Requirements	76
4.1.3 Tool Requirements	78
4.2 Equipment Handling	80
4.3 Installing the Equipment	81
4.4 Installing the Smart Meter	86
5 System Wirings	88
5.1 System Wiring Electrical Block Diagram	89
5.2 Detailed System Wiring Diagram	93

5.2.1 Detailed System Wiring Diagram for Single Inverter.....	97
5.2.2 Detailed System Wiring Diagram for Parallel System.....	106
5.3 Preparing Materials.....	110
5.3.1 Preparing Breakers.....	111
5.3.2 Preparing Cables.....	114
5.4 Connecting the PE cable.....	118
5.5 Connecting the PV Cable.....	119
5.6 Connecting the Battery Cable.....	121
5.7 Connecting the AC Cable.....	123
5.8 Connecting the Meter Cable.....	125
5.9 Connecting the Inverter Communication Cable.....	128
6 System Commissioning.....	133
6.1 Check Before Power ON.....	133
6.2 Power ON.....	133
6.3 Installing the Protective Cover.....	137
6.4 Indicators.....	137
6.4.1 Inverter Indicators.....	137
6.4.2 Battery Indicators.....	140
6.4.3 Smart Meter Indicators GM330&GMK330.....	141
6.4.3.1 Indicator Description.....	141
6.4.4 Smart Dongle Indicator.....	142
7 System Commissioning & Plant Monitoring.....	145

7.1 Setting Inverter Parameters via App	145
7.1.1 Downloading and Installing SEMS+ App	145
7.2 Plant Monitoring via SEMS+ WEB	146
8 Maintenance	147
8.1 Power OFF the System	147
8.2 Removing the Equipment	149
8.3 Disposing of the Equipment	150
8.4 Routine Maintenance	150
8.5 fault	153
8.5.1 Viewing Fault/Alarms Information	153
8.5.2 Fault Information and Troubleshooting	154
8.5.2.1 Inverter Fault	156
8.5.2.1.1 Troubleshooting (Fault Code F01-F40)	156
8.5.2.1.2 Troubleshooting (Fault Code F41-F80)	173
8.5.2.1.3 Troubleshooting (Fault Code F81-F121)	182
8.5.2.1.4 Troubleshooting (Fault Code F122-F163)	192
8.5.2.1.5 Troubleshooting by Fault Symptom	201
8.5.2.2 Battery Fault	219
9 technical parameter	241
9.1 Inverter Parameters	241
9.2 Battery Technical Data	294
9.3 Smart Meter Technical Data	298

9.3.1 GM330	298
9.3.2 GMK330	300
9.4 Smart Dongle Technical Data	301
9.4.1 WiFi/LAN Kit-20	301
9.4.2 4G Kit-G20	302
10 Appendix	304
10.1 FAQ	304
10.1.1 How to conduct auxiliary detection for smart meters/CT?	304
10.1.2 How to Upgrade the Device Version	304
10.2 Explanation of Terms	305
10.3 Battery SN Code Meaning	306
11 Contact Information	308

# 1 Safety Precautions

The safety precautions information contained in this document must always be followed when operating the device.

## WARNING

The device has been strictly designed and tested in accordance with safety regulations, but as an electrical device, before performing any operations on the device, relevant safety instructions must be followed. Improper operation may lead to serious injury or property damage.

## 1.1 General Safety

### NOTICE

- Due to product version upgrades or other reasons, the document content will be updated periodically. Unless otherwise agreed, the document content cannot replace the safety precautions on product labels. All descriptions in the document are for guidance only.
- Please read this document carefully before installing the device to understand the product and precautions.
- All operations of the device must be performed by professional and qualified electrical technicians who are familiar with the relevant standards and safety regulations at the project location.
- When operating the device, use insulated tools and wear personal protective equipment to ensure personal safety. When handling electronic components, wear anti-static gloves, anti-static wrist straps, anti-static clothing, etc., to protect the device from electrostatic damage.
- Unauthorized disassembly or modification may cause device damage, and such damage is not covered by the warranty.
- Device damage or personal injury caused by not installing, using, or configuring the device according to the requirements of this document or the corresponding user manual is beyond the manufacturer's liability. For more product warranty information, please obtain it through the official website:  
<https://en.goodwe.com/warrantyrelated.html>.

## 1.2 personnel requirements

## NOTICE

To ensure safety, compliance, and efficiency throughout the entire process of equipment transportation, Installation, wiring, operation, and maintenance, operations must be performed by qualified personnel.

1. Qualified personnel include:
  - Personnel who have mastered knowledge of equipment working principles, system structure, risks and hazards, and have received professional operation training or possess extensive practical experience.
  - Personnel who have received relevant technical and safety training, possess certain operational experience, are aware of potential dangers specific tasks may pose to themselves, and can take protective measures to minimize risks to themselves and others.
  - Qualified electrical technicians meeting the regulatory requirements of the country/region.
  - Personnel holding a degree in electrical engineering/an advanced diploma in electrical discipline or equivalent/possessing professional qualifications in the electrical field, with at least 2/3/4 years of experience in testing and supervision work using electrical equipment safety standards.
2. Personnel involved in special tasks such as electrical work, work at heights, and special equipment operation must hold valid qualification certificates as required by the equipment's location.
3. Medium-voltage equipment operation must be performed by certified high-voltage electricians.
4. Equipment and component replacement is only permitted to be performed by authorized personnel.

## 1.3 System Safety



- Before performing electrical connections, disconnect all upstream switches of the device to ensure it is powered off. Working on live circuits is strictly prohibited, as it may lead to hazards such as electric shock.
- To prevent personal injury or equipment damage caused by working on live circuits, a circuit breaker must be added to the voltage input side of the device.
- All operations including transportation, storage, installation, operation, use, and maintenance must comply with applicable laws, regulations, standards, and specifications.
- The specifications of cables and components used for electrical connections must comply with local laws, regulations, standards, and specifications.
- Use the cable connectors provided in the package to connect the device cables. If other models of connectors are used, any resulting equipment damage is not within the manufacturer's liability.
- Ensure all cables of the device are correctly connected, securely fastened, and free from looseness. Improper wiring may cause poor contact or damage the equipment.
- The equipment's protective grounding wire must be firmly connected.
- To protect the equipment and its components from damage during transportation, ensure that transport personnel are professionally trained. Record the operation steps during transportation and keep the equipment balanced to avoid dropping.
- The equipment is heavy. Assign personnel according to the equipment's weight to prevent it from exceeding the human lifting capacity and causing injury from falling.
- Ensure the equipment is placed stably and not tilted. Equipment tipping over may cause equipment damage and personal injury.

 **WARNING**

- During equipment installation, avoid having the terminals bear weight, as this may cause terminal damage.
- If the cable is subjected to excessive tension, it may lead to poor connections. When wiring, leave a certain length of cable slack before connecting it to the equipment's terminal ports.
- Cables of the same type should be bundled together. Different types of cables should be routed at least 30mm apart and must not be intertwined or cross-routed.
- Using cables in high-temperature environments may cause insulation aging and damage. Maintain a distance of at least 30mm between cables and heat-generating components or the periphery of heat source areas.

### **1.3.1 PV String Safety**

## WARNING

- Ensure the component frame and mounting system are properly grounded.
- After connecting the DC cables, ensure the cable connections are tight and secure with no looseness. Improper wiring may cause poor contact or high impedance, and damage the inverter.
- Use a multimeter to measure the positive and negative poles of the DC cables to ensure correct polarity, with no reverse connection; and that the voltage is within the permissible range.
- Use a multimeter to measure the DC cables to ensure correct polarity, with no reverse connection; the voltage should be lower than the maximum DC input voltage. Damage caused by reverse connection and overvoltage is not covered by the equipment manufacturer's warranty.
- The PV string output does not support grounding. Before connecting the PV string to the inverter, ensure the minimum insulation resistance to ground of the PV string meets the minimum insulation resistance requirement ( $R = \text{Max. Input Voltage (V)} / 30\text{mA}$ ).
- Do not connect the same PV string to multiple inverters, as this may damage the inverters.
- The PV modules used with the inverter must comply with IEC 61730 Class A standards.
- When the PV string input voltage or input current is high, it may cause the inverter output power to derate.

### 1.3.2 Inverter Safety

## WARNING

- Ensure the voltage and frequency at the grid connection point comply with the inverter's grid-connection specifications.
- It is recommended to install protective devices such as circuit breakers or fuses on the AC side of the inverter. The rating of the protective device must be greater than 1.25 times the maximum AC output current of the inverter.
- If the inverter triggers an arc fault alarm less than 5 times within 24 hours, the alarm can be cleared automatically. After the 5th arc fault alarm, the inverter will shut down for protection. The inverter can resume normal operation only after the fault is cleared.
- If a battery is not configured in the photovoltaic system, it is not recommended to use the BACK-UP function, as it may cause a system power outage risk.
- Grid voltage and frequency fluctuations may cause the inverter output power to derate.

### 1.3.3 Battery Safety

## DANGER

- Before operating any devices in the system, ensure that the devices are powered off to avoid the risk of electric shock. During device operation, strictly adhere to all safety precautions in this manual and the safety labels on the devices.
- Do not disassemble, modify, or repair the battery without official authorization from the device manufacturer. Otherwise, it may cause electric shock or device damage, and any losses incurred are beyond the manufacturer's liability.
- Do not impact, pull, drag, squeeze, or step on the device, and do not place the battery in fire, as the battery may explode.
- Do not place the battery in high-temperature environments. Ensure there are no heat sources near the battery and that it is not exposed to direct sunlight. If the ambient temperature exceeds 60°C, it may cause a fire.
- Do not use the battery if it has obvious defects, cracks, damage, or other conditions. Battery damage may lead to electrolyte leakage.
- Do not move the battery system while it is operating. If battery replacement or addition is needed, contact the after-sales service center.
- Battery short circuits may cause personal injury. The instantaneous high current from a short circuit can release a large amount of energy, which may lead to a fire.
- To protect the battery pack and its components from damage during transportation, ensure that transport personnel are professionally trained. Record the operating steps during transportation and keep the device balanced to avoid dropping.
- The battery device is heavy. Assign personnel according to the device's weight to prevent it from exceeding the weight range that can be manually handled, which could cause injury to personnel.

 **WARNING**

- Battery current may be affected by factors such as temperature, Humidity, weather conditions, etc., which may cause current limiting and affect load capacity.
- If the battery cannot start, contact the after-sales service center as soon as possible. Otherwise, the battery may be permanently damaged.
- Regularly inspect and maintain the battery according to its maintenance requirements.
- Ensure that the battery system is not damaged during transportation and storage. Ensure that the device is placed stably and not tilted, as tipping may cause device damage and personal injury.

### Emergency Response Measures

- Battery electrolyte leakage  
If a battery module leaks electrolyte, avoid contact with the leaking liquid or gas. Electrolyte is corrosive and contact may cause skin irritation and chemical burns. If accidental contact with the leaked substance occurs, take the following actions:
  - inhalation: Evacuate from the contaminated area and seek medical help immediately.
  - Eye contact: Rinse with clean water for at least 15 minutes and seek medical help immediately.
  - Skin contact: Wash the affected area thoroughly with soap and water and seek medical help immediately.
  - Ingestion: Induce vomiting and seek medical assistance immediately.
- Fire
  - When the battery temperature exceeds 150°C, there is a risk of fire. A battery fire may release toxic and harmful gases.
  - To prevent fire, ensure carbon dioxide or water fire extinguishing equipment is available near the device.
  - When extinguishing a fire, do not use ABC dry powder fire extinguishers. Firefighters must wear protective clothing and self-contained breathing apparatus.
- Battery triggers fire protection  
For batteries equipped with optional fire protection functionality, after the fire protection function is triggered, perform the following actions:
  - Immediately cut off the main power switch to ensure no current flows through the battery system.

- Conduct a preliminary visual inspection of the battery for any damage, deformation, leakage, or unusual odor. Check the battery casing, connectors, and cables.
- Use a temperature sensor to detect the battery and its ambient temperature to ensure there is no risk of overheating.
- Isolate and label the damaged battery, and dispose of it properly according to local regulations.

### 1.3.4 Smart Meter Safety



#### WARNING











If the grid voltage fluctuation exceeds 265V, long-term overvoltage operation may cause damage to the meter. It is recommended to add a fuse with a rated current of 0.5A on the voltage input side of the meter to protect it.







## 1.4 Safety Symbols and Certification Marks

#### DANGER

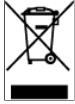
- After equipment installation, labels and warning signs on the enclosure must remain clearly visible. Do not cover, alter, or damage them.
- The following enclosure warning label descriptions are for reference only. Please refer to the actual labels used on the equipment.

No.	Symbol	Meaning
1		Potential hazard exists during equipment operation. Please take protective measures when operating the equipment.
2		High voltage hazard. High voltage is present during equipment operation. Please ensure the equipment is powered off before performing any operations.

No.	Symbol	Meaning
3		The inverter surface is at high temperature. Do not touch during operation to avoid burns.
4		Use the equipment properly. There is a risk of explosion under extreme conditions.
5		Battery contains flammable materials. Beware of fire.
6		The equipment contains corrosive electrolyte. Avoid contact with leaked electrolyte or volatile gases.
7		Delayed discharge. After powering off the equipment, please wait 5 minutes for it to discharge completely.
8		Keep the equipment away from open flames or ignition sources.
9		Keep the equipment out of reach of children.
10		Do not extinguish with water.
11		Please read the product manual carefully before operating the equipment.
12		Personal protective equipment must be worn during installation, operation, and maintenance.

No.	Symbol	Meaning
13		This equipment must not be disposed of as household waste. Please dispose of it according to local laws and regulations, or return it to the manufacturer.
14		Grounding point.
15		Recycling symbol.
16		CE certification mark.
17		TUV mark.
18		RCM mark.

## 1.5 EU Declaration of Conformity

### 1.5.1 Equipment with Wireless Communication Modules

Equipment with wireless communication modules sold in the European market must comply with the following directives:

- Radio Equipment Directive 2014/53/EU (RED)
- Restrictions of Hazardous Substances Directive 2011/65/EU and (EU) 2015/863 (RoHS)
- Waste Electrical and Electronic Equipment 2012/19/EU
- Registration, Evaluation, Authorization and Restriction of Chemicals (EC) No 1907/2006 (REACH)

### 1.5.2 Equipment without Wireless Communication Modules (Except Battery)

Equipment without wireless communication modules that can be sold in the European market meets the requirements of the following directives:

- Electromagnetic compatibility Directive 2014/30/EU (EMC)
- Electrical Apparatus Low Voltage Directive 2014/35/EU (LVD)
- Restrictions of Hazardous Substances Directive 2011/65/EU and (EU) 2015/863 (RoHS)
- Waste Electrical and Electronic Equipment 2012/19/EU
- Registration, Evaluation, Authorization and Restriction of Chemicals (EC) No 1907/2006 (REACH)

### **1.5.3 Battery**

The Battery sold in the European market complies with the following directives:

- Electromagnetic compatibility Directive 2014/30/EU (EMC)
- Electrical Apparatus Low Voltage Directive 2014/35/EU (LVD)
- Restrictions of Hazardous Substances Directive 2011/65/EU and (EU) 2015/863 (RoHS)\*<sup>1</sup>
- Regulation (EU) 2023/1542 Article 12 - Safety of stationary battery energy storage systems
- Regulation (EU) 2023/1542 Article 10 - Performance and durability requirements for rechargeable industrial batteries, LMT batteries and electric vehicle batteries
- Regulation (EU) 2023/1542 Article 14 - Information on the state of health and expected lifetime of batteries
- Waste Electrical and Electronic Equipment 2012/19/EU
- Registration, Evaluation, Authorization and Restriction of Chemicals (EC) No 1907/2006 (REACH)

Our Battery products comply with the hazardous substance restriction requirements stipulated by this act.

More EU Declaration of Conformity can be obtained from [Official Website](#) Acquisition.

# 2 System Introduction

## 2.1 System Overview

The Household Storage Integrated Unit solution integrates devices such as inverters, batteries, smart meters, and smart communication sticks. In a photovoltaic system, it converts solar energy into electricity to meet household power demands. The energy IoT devices in the system control power-consuming devices by identifying the overall power situation in the system, thereby achieving intelligent management of power for load usage, storage to batteries, or output to the grid, etc.

### WARNING

- The energy storage system is not suitable for connecting to devices that rely on stable power supply, such as life-sustaining medical equipment. Please ensure that system power failure will not cause personal injury.
- If the residential storage all-in-one unit is in a high-temperature environment or under BMS current limiting conditions, it may cause the battery charging power to be limited, leading to excessively high system voltage triggering overvoltage protection.
- The inverter only supports GoodWe brand batteries specified in this manual. If no battery is connected, it can only operate in grid-tied mode and must be installed on the base provided with the package.
- In microgrid scenarios, it is recommended that the PV open-circuit voltage of the residential storage all-in-one unit be  $< 0.85 * PV$  maximum input voltage to avoid system overvoltage triggering overvoltage protection under harsh operating conditions.
- In microgrid scenarios, please ensure the over-frequency power reduction point of the grid-tied inverter matches that of the residential storage all-in-one unit.
- If output power limiting is required for the grid-tied inverter, please connect a separate meter or CT device.
- Please ensure the over-frequency power reduction curve of the grid-tied inverter is set as follows:
  - Set the endpoint power to 0% P<sub>n</sub>
  - Set the response delay time to 0, and disable the hysteresis function
- In a system where the inverter operates completely off-grid, if the battery

## WARNING

experiences prolonged periods of low sunlight or rainy weather without timely recharging, it may lead to over-discharge, causing battery performance degradation or damage. To ensure long-term stable system operation, avoid completely draining the battery. Recommended measures are as follows:

- When operating off-grid, set a minimum SOC protection threshold. It is recommended to set the off-grid battery SOC lower limit to 30%.
- When the SOC approaches the protection threshold, the system will automatically enter load limiting or protection mode.
- If there are multiple consecutive days of insufficient sunlight and the battery SOC is too low, promptly replenish the battery using an external energy source (such as a generator or grid-assisted charging).
- Regularly check the battery status to ensure it remains within a safe operating range.
- It is recommended to perform a full charge and discharge cycle on the battery every six months to calibrate SOC accuracy.
- Due to product version upgrades or other reasons, document content is updated periodically. For the compatibility relationship between inverters and IoT products, please refer to:  
[https://en.goodwe.com/Ftp/EN/Downloads/User%20Manual/GW\\_Compatibility-list-of-GoodWe-inverters-and-IoT-products-EN.pdf](https://en.goodwe.com/Ftp/EN/Downloads/User%20Manual/GW_Compatibility-list-of-GoodWe-inverters-and-IoT-products-EN.pdf)
- For detailed networking and wiring schemes for each scenario, please refer to:  
[5.2.Detailed System Wiring Diagram\(Page 93\)](#).

When the energy storage system is in off-grid state, it can normally supply the following loads:

### BACK-UP Port Off-Grid Load Capacity Specification

Inverter Model	GW5K-ETA-G20 GW6K-ETA-G20 GW8K-ETA-G20 GW9.999K-ETA-G20 GW10K-ETA-G20 GW12K-ETA-G20 GW15K-ETA-G20 GW20K-ETA-G20 GW5K-BTA-G20 GW6K-BTA-G20 GW8K-BTA-G20 GW9.999K-BTA-G20 GW10K-BTA-G20 GW12K-BTA-G20 GW15K-BTA-G20 GW20K-BTA-G20	GW25K-ETA-G20 GW29.999K-ETA-G20 GW30K-ETA-G20 GW25K-BTA-G20 GW29.999K-BTA-G20 GW30K-BTA-G20		
Load Type	Single-Phase	Three-Phase	Single-Phase	Three-Phase
Single Inductive Load Rated Power (kVA)	1.1	3.3	2.2	6.6
Total Rated Power of Multiple Inductive Loads (kVA)	$0.4 \cdot P_n / 3$	$0.4 \cdot P_n$	$0.4 \cdot P_n / 3$	$0.4 \cdot P_n$
Capacitive Load (kVA)	$0.33 \cdot P_n / 3$	$0.33 \cdot P_n$	$0.33 \cdot P_n / 3$	$0.33 \cdot P_n$
Half-Wave Load (kW)	2	-	3	-

## BACK-UP Port Off-Grid Load Capacity Specification

### Note:

- $P_n$ : Inverter rated output power.
- Half-wave load: Some old or non-EMC compliant household appliances (e.g., hair dryers, small heaters using half-wave rectification).
- If the total power of multiple inductive loads calculated based on the rated power is less than the rated power of a single inductive load, then Total Rated Power of Multiple Inductive Loads = Single Inductive Load Rated Power.
- If inductive loads are to be used, it is recommended to use them with a frequency converter.
- For 2 or more units in parallel, the allowed total inductive load rated power = Single Inductive Load Rated Power \* Number of Parallel Units \* 80%.

### General Scenario

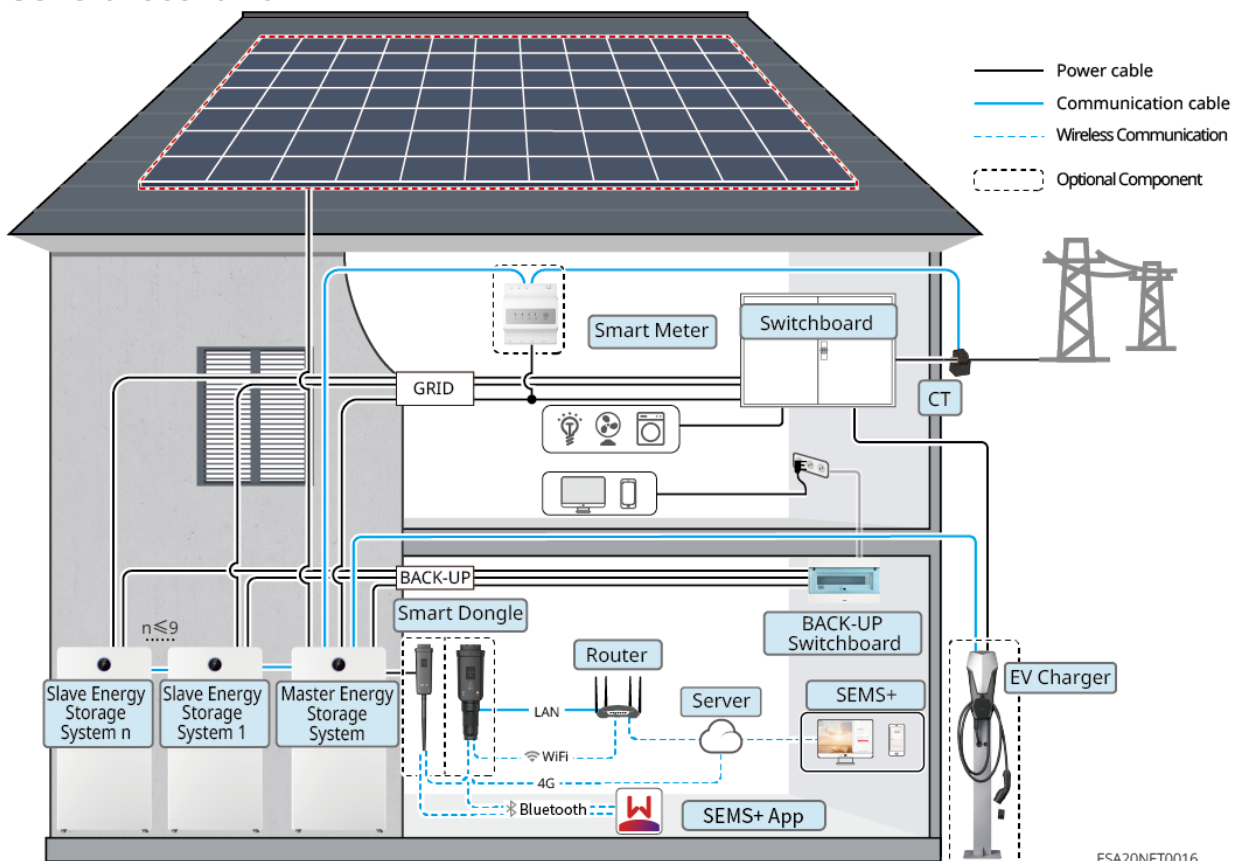

Device Type	model	Description
hybrid inverter	GW5K-ETA-G20 GW6K-ETA-G20 GW8K-ETA-G20 GW9.999K-ETA-G20 GW10K-ETA-G20 GW12K-ETA-G20 GW15K-ETA-G20 GW20K-ETA-G20 GW25K-ETA-G20 GW29.999K-ETA-G20 GW30K-ETA-G20 GW5K-BTA-G20 GW6K-BTA-G20 GW8K-BTA-G20 GW9.999K-BTA-G20 GW10K-BTA-G20 GW12K-BTA-G20 GW15K-BTA-G20 GW20K-BTA-G20 GW25K-BTA-G20 GW29.999K-BTA-G20 GW30K-BTA-G20	<ul style="list-style-type: none"> <li>• Connection to GoodWe AC charging piles is only supported in single-unit scenarios.</li> <li>• The system supports a maximum of 10 inverters to form a parallel system, supporting hybrid on-grid/off-grid parallel connection of inverters with different power ratings. When mixing, it is recommended to use a high-power inverter as the master unit. Microgrid functionality is not supported in parallel systems.</li> <li>• Supports generator control and generator charging of the battery. If connecting a generator, please use the GMK330 or GM330 Smart Meter.</li> <li>• In a parallel system, each inverter requires the installation of a WiFi/LAN Kit-20.</li> <li>• The following version requirements must be met for system networking:               <ul style="list-style-type: none"> <li>◦ Inverter ARM software version must be 03.138 or higher.</li> <li>◦ Inverter DSP software version must be 01.1025 or higher.</li> </ul> </li> </ul>

Device Type	model	Description
Battery system	GW5.1-BAT-D-G20 GW5.1-BAT-D-G21 GW8.3-BAT-D-G20 GW8.3-BAT-D-G21 GW6.0-BAT-D-G20 GW9.0-BAT-D-G20	<ul style="list-style-type: none"> <li>• Different models of battery modules can be mixed.</li> <li>• The system supports 5-108kWh, meeting various power and energy matching requirements.</li> <li>• Battery heating film is optional. The "Battery Heating" function can only be enabled on models configured with the heating film. Batteries without the heating film should not be used in low-temperature environments, as this may prevent the device from operating.</li> <li>• The battery heating function is unavailable when GW5.1-BAT-D-G20, GW8.3-BAT-D-G20, GW5.1-BAT-D-G21, GW8.3-BAT-D-G21, GW6.0-BAT-D-G20, GW9.0-BAT-D-G20 are mixed.</li> <li>• If the system requires mixed battery use or split-type capacity expansion, ensure the BMS software version is V06 or higher and the DCDC version is V05 or higher.</li> </ul>
Smart Meter	Inverter Built-in Meter GMK330 (purchased from GoodWe)	

Device Type	model	Description
	GM330 (purchased from GoodWe)	<ul style="list-style-type: none"> <li>• Built-in Meter: Please use the CT shipped with the inverter for connection. <ul style="list-style-type: none"> <li>◦ CT ratio is 120A:40mA.</li> <li>◦ If the inverter's built-in meter is insufficient, contact your dealer to purchase a GMK330 or GM330 Smart Meter.</li> </ul> </li> <li>• GMK330: CT cannot be replaced; CT ratio is 120A:40mA</li> <li>• GM330: CT can be purchased from GoodWe or separately; CT ratio requirement: nA/5A <ul style="list-style-type: none"> <li>◦ nA: CT primary side input current, where n ranges from 200 to 5000</li> <li>◦ 5A: CT secondary side output current</li> </ul> </li> <li>• If the number of parallel inverters exceeds 2, or if the wire gauge or range of the standard CT does not meet the total current requirement of the on-site parallel system, please use the GM330 Smart Meter.</li> </ul>
Smart dongle	WiFi/LAN Kit-20	<ul style="list-style-type: none"> <li>• Suitable for single inverter and parallel inverter system networking scenarios.</li> <li>• Uses Bluetooth signal for local configuration of device parameters and viewing device operation information; uploads system operation information to the monitoring platform via WiFi or LAN.</li> <li>• Please ensure the Smart dongle firmware version is 07 or higher.</li> </ul>

Device Type	model	Description
	4G Kit-G20	<ul style="list-style-type: none"> <li>Suitable for single inverter system networking scenarios.</li> <li>Uses Bluetooth signal for local configuration of device parameters and viewing device operation information; uploads system operation information to the monitoring platform via 4G.</li> </ul>

### Microgrid Scenario

When the grid-tied inverter is connected to the hybrid inverter's BACK-UP port, it is a microgrid scenario.

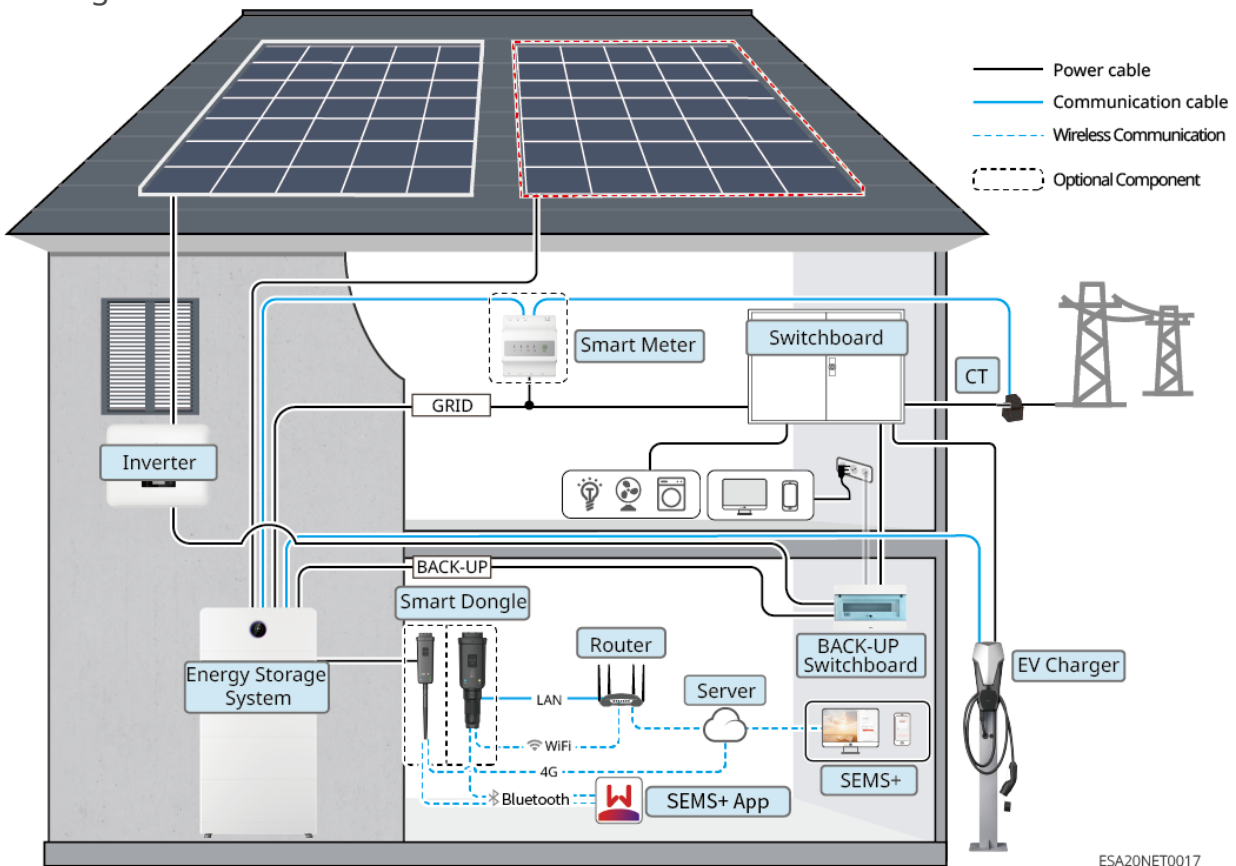

Device Type	model	Description
hybrid inverter	GW5K-ETA-G20 GW6K-ETA-G20 GW8K-ETA-G20 GW9.999K-ETA-G20 GW10K-ETA-G20 GW12K-ETA-G20 GW15K-ETA-G20 GW20K-ETA-G20 GW25K-ETA-G20 GW29.999K-ETA-G20 GW30K-ETA-G20 GW5K-BTA-G20 GW6K-BTA-G20 GW8K-BTA-G20 GW9.999K-BTA-G20 GW10K-BTA-G20 GW12K-BTA-G20 GW15K-BTA-G20 GW20K-BTA-G20 GW25K-BTA-G20 GW29.999K-BTA-G20 GW30K-BTA-G20	<ul style="list-style-type: none"> <li>• In a microgrid scenario, only one hybrid inverter is supported in the system.</li> <li>• In a microgrid scenario, connecting a generator is not supported.</li> </ul>

Device Type	model	Description
Battery system	GW5.1-BAT-D-G20 GW5.1-BAT-D-G21 GW8.3-BAT-D-G20 GW8.3-BAT-D-G21 GW6.0-BAT-D-G20 GW9.0-BAT-D-G20	<ul style="list-style-type: none"> <li>• Different models of battery modules can be mixed and used.</li> <li>• The system supports 5-108kWh, meeting usage with different power and energy matching requirements.</li> <li>• The battery heating film is optional. The "Battery Heating" function can only be enabled for models configured with the heating film. Batteries without the heating film should not be used in low-temperature environments, as this may prevent the device from operating.</li> <li>• When GW5.1-BAT-D-G20, GW8.3-BAT-D-G20, GW5.1-BAT-D-G21, GW8.3-BAT-D-G21, GW6.0-BAT-D-G20 , GW9.0-BAT-D-G20 are mixed, the battery heating function is unavailable.</li> <li>• If the system requires mixed battery use or split-type expansion, ensure the BMS software version is V06 or above and the DCDC version is V05 or above.</li> </ul>
Smart Meter	Inverter Built-in Meter	<ul style="list-style-type: none"> <li>• Built-in Meter: Please use the CT shipped with the inverter to connect to the inverter.               <ul style="list-style-type: none"> <li>◦ CT ratio is 120A:40mA</li> <li>◦ If the inverter's built-in meter is insufficient, contact your dealer to purchase a GMK330 or GM330 Smart Meter.</li> </ul> </li> <li>• GMK330: CT cannot be replaced; CT ratio is 120A:40mA</li> <li>• GM330: CT can be purchased from GoodWe or separately; CT ratio is nA:5A</li> </ul>
	GMK330 (Purchase from GoodWe)	
	GM330 (Purchase from GoodWe)	

Device Type	model	Description
Smart dongle	WiFi/LAN Kit-20	<ul style="list-style-type: none"> <li>• Uses Bluetooth signal for local configuration of device parameters and viewing device operation information; uploads system operation information to the monitoring platform via WiFi or LAN.</li> <li>• Ensure the Smart dongle's firmware version is 07 or above.</li> </ul>
	4G Kit-G20	<ul style="list-style-type: none"> <li>• Uses Bluetooth signal for local configuration of device parameters and viewing device operation information; uploads system operation information to the monitoring platform via 4G.</li> </ul>

Device Type	model	Description
grid-tied PV inverter	-	<ul style="list-style-type: none"> <li>• GoodWe brand grid-tied PV inverters are recommended; third-party grid-tied PV inverters are supported.</li> <li>• In a microgrid scenario, ensure the grid-tied PV inverter's rated output power <math>\leq</math> the hybrid inverter's rated output power.</li> <li>• When the microgrid system is in grid-connected state, if power limitation is required, ensure: <ul style="list-style-type: none"> <li>◦ For the hybrid inverter, set it in the Grid Power Limit interface of the SEMS+ App. For the grid-tied PV inverter, set it according to the actual tool used.</li> <li>◦ To ensure the grid-tied PV inverter can continue generating power, adjust the hybrid inverter's output power in the Microgrid Mode interface of the SEMS+ App.</li> </ul> </li> </ul> <p>Note: Different grid-tied PV inverters have different output power control precision. Set the grid power limit parameter value according to the actual situation.</p>

### Coupling Scenario

When the grid-tied inverter is connected to the hybrid inverter's GRID port, it is a coupling scenario.

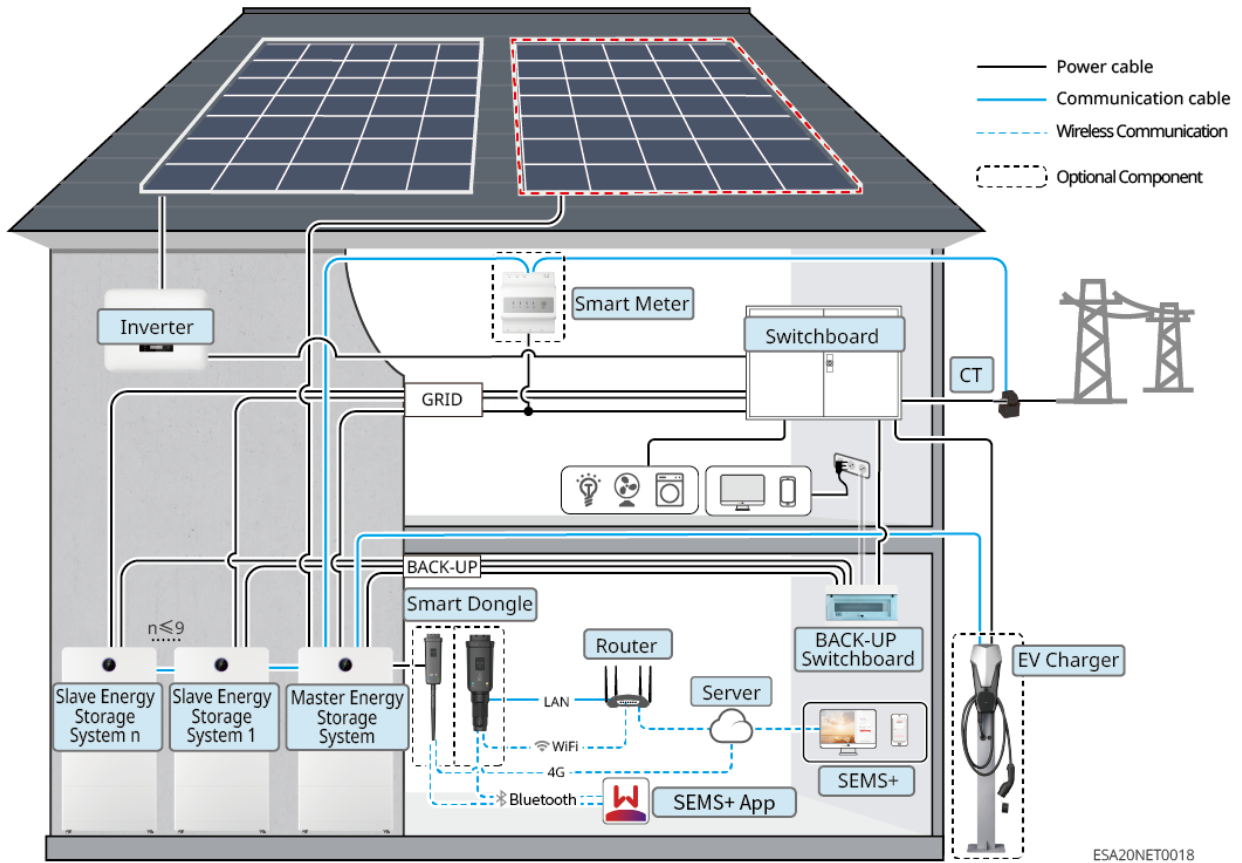

Device Type	model	Description
hybrid inverter	GW5K-ETA-G20 GW6K-ETA-G20 GW8K-ETA-G20 GW9.999K-ETA-G20 GW10K-ETA-G20 GW12K-ETA-G20 GW15K-ETA-G20 GW20K-ETA-G20 GW25K-ETA-G20 GW29.999K-ETA-G20 GW30K-ETA-G20 GW5K-BTA-G20 GW6K-BTA-G20 GW8K-BTA-G20 GW9.999K-BTA-G20 GW10K-BTA-G20 GW12K-BTA-G20 GW15K-BTA-G20 GW20K-BTA-G20 GW25K-BTA-G20 GW29.999K-BTA-G20 GW30K-BTA-G20	<ul style="list-style-type: none"> <li>• Only supports connection to GoodWe AC charging piles in single-unit scenarios.</li> <li>• The system supports up to 10 inverters to form a parallel system, and supports hybrid parallel connection of inverters with different power ratings in on-grid/off-grid modes. When mixing, it is recommended to use a high-power inverter as the master; the microgrid function is not supported during parallel operation.</li> <li>• Supports generator control and generator charging of the battery. If a generator needs to be connected, please use the GMK330 or GM330 Smart Meter.</li> <li>• In a parallel system, each inverter needs to be installed with a WiFi/LAN Kit-20.</li> <li>• The following version requirements must be met during system networking:               <ul style="list-style-type: none"> <li>◦ The Inverter ARM software version is 03.138 or higher.</li> <li>◦ The Inverter DSP software version is 01.1025 or higher.</li> </ul> </li> </ul>

Device Type	model	Description
Battery system	GW5.1-BAT-D-G20 GW5.1-BAT-D-G21 GW8.3-BAT-D-G20 GW8.3-BAT-D-G21 GW6.0-BAT-D-G20 GW9.0-BAT-D-G20	<ul style="list-style-type: none"> <li>• Different models of battery modules can be mixed.</li> <li>• The system supports 5-108kWh, meeting usage with different power and energy matching requirements.</li> <li>• The battery heating pad is optional. The "Battery Heating" function can only be enabled on models configured with the heating pad. Batteries without the heating pad should not be used in low-temperature environments, as this may cause the device to fail to operate.</li> <li>• The battery heating function is unavailable when GW5.1-BAT-D-G20, GW8.3-BAT-D-G20, GW5.1-BAT-D-G21, GW8.3-BAT-D-G21, GW6.0-BAT-D-G20 , GW9.0-BAT-D-G20 are mixed.</li> <li>• If the system requires mixed battery use or split-type expansion, ensure the BMS software version is V06 or higher and the DCDC version is V05 or higher.</li> </ul>
Smart Meter	Inverter Built-in Meter  GMK330 (Purchase from GoodWe)	

Device Type	model	Description
	GM330 (Purchase from GoodWe)	<ul style="list-style-type: none"> <li>• Built-in Meter: Please use the CT shipped with the unit to connect to the inverter. <ul style="list-style-type: none"> <li>◦ The CT ratio is 120A:40mA.</li> <li>◦ If the inverter's built-in meter does not meet the usage requirements, contact the dealer or others to purchase a GMK330 or GM330 Smart Meter.</li> </ul> </li> <li>• GMK330: CT cannot be replaced; CT ratio is 120A:40mA</li> <li>• GM330: CT can be purchased from GoodWe or separately; CT ratio requirement: nA/5A <ul style="list-style-type: none"> <li>◦ nA: CT primary side input current, where n ranges from 200 to 5000</li> <li>◦ 5A: CT secondary side output current</li> </ul> </li> <li>• If the number of parallel inverters exceeds 2, or if the wire gauge or range of the standard CT does not meet the total current requirements of the on-site parallel system, please use the GM330 Smart Meter.</li> </ul>
Smart dongle	WiFi/LAN Kit-20	<ul style="list-style-type: none"> <li>• Uses Bluetooth signals for local configuration of device parameters and viewing device operation information; uploads system operation information to the monitoring platform via WiFi or LAN.</li> <li>• Ensure the firmware version of the Smart dongle is 07 or higher.</li> </ul>
	4G Kit-G20	Uses Bluetooth signals for local configuration of device parameters and viewing device operation information; uploads system operation information to the monitoring platform via 4G.

Device Type	model	Description
grid-tied PV inverter	-	<ul style="list-style-type: none"> <li>• It is recommended to use GoodWe brand grid-tied PV inverters; third-party grid-tied PV inverters are supported.</li> <li>• In coupling scenarios, ensure the rated output power of the grid-tied PV inverter <math>\leq</math> the rated output power of the hybrid inverter.</li> <li>• When the coupling system is in grid-connected status, if power limitation is required, ensure: The hybrid inverter needs to be set via the grid power limitation interface in the SEMS+ App; set the grid-tied PV inverter according to the actual tool used.</li> </ul> <p>Note: The output power control accuracy varies for different grid-tied PV inverters; please set the grid power limitation parameter values according to the actual situation.</p>

## 2.2 Product Overview

### 2.2.1 Residential Three-Phase All-in-One Unit

#### **Residential Three-Phase All-in-One Unit:**

The Residential Three-Phase All-in-One Unit adopts a blind-plug stacking connection method and integrates the Inverter and Battery units through modular design.

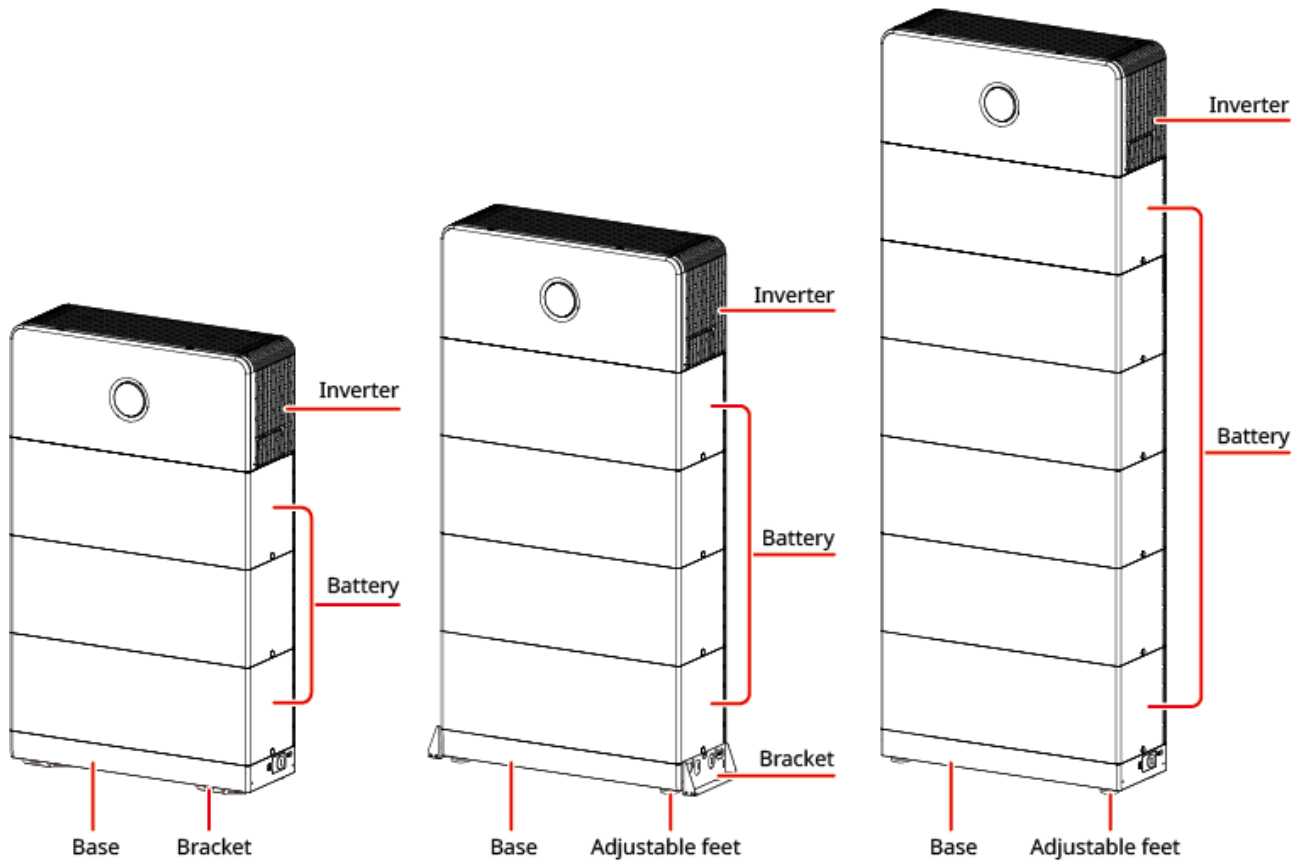

ESA20DSC0007

The energy storage system supports Battery capacity expansion. The total Battery capacity is determined by the quantity and specifications of the Battery modules. Configuration must strictly adhere to the limitations specified in this section. Overall system configuration description:

**A:** GW5.1-BAT-D-G20, GW5.1-BAT-D-G21, GW6.0-BAT-D-G20

**B:** GW8.3-BAT-D-G20, GW8.3-BAT-D-G21, GW9.0-BAT-D-G20

Mounting Method	Expansion Groups	Single Group Stacking	Total Batteries
Floor Installation	≤3 groups	Freestanding ≤4 units Wall-mounted ≤6 units	≤12 units
Wall-mounted Installation (A)	≤3 groups	≤3 units	≤9 units
Wall-mounted Installation(A/B/A+B)	≤3 groups	≤2 units	≤6 units

Mounting Method	Expansion Groups	Single Group Stacking	Total Batteries
Note: Expansion Groups × Single Group Stacking Quantity ≤ Total System Batteries			

### Wall-mounted Installation

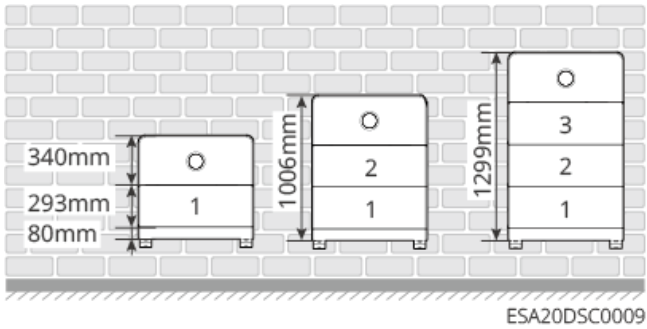

sign

### Floor-standing Installation

- Wall-proximity Installation

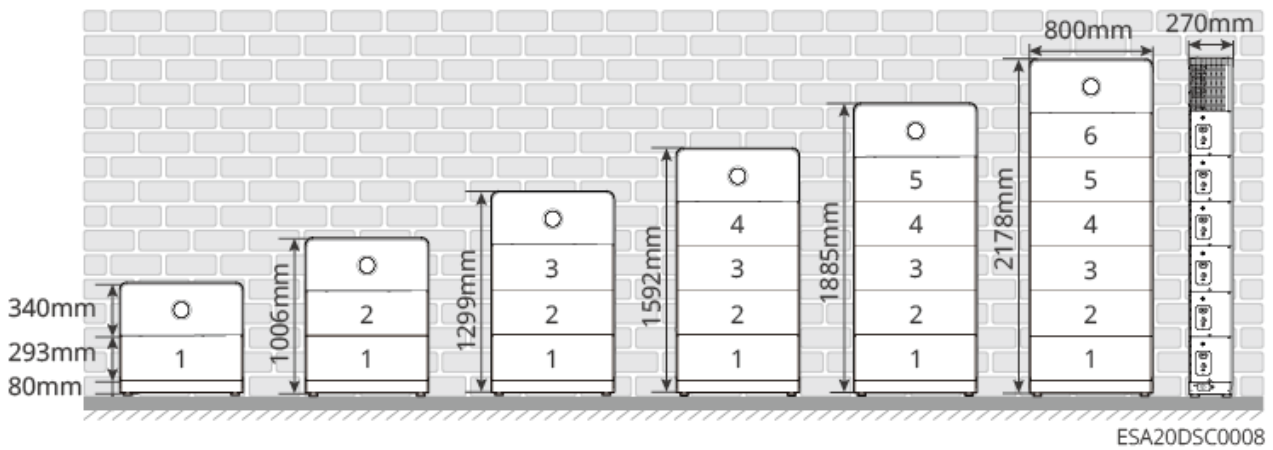

- Wall-distance Installation

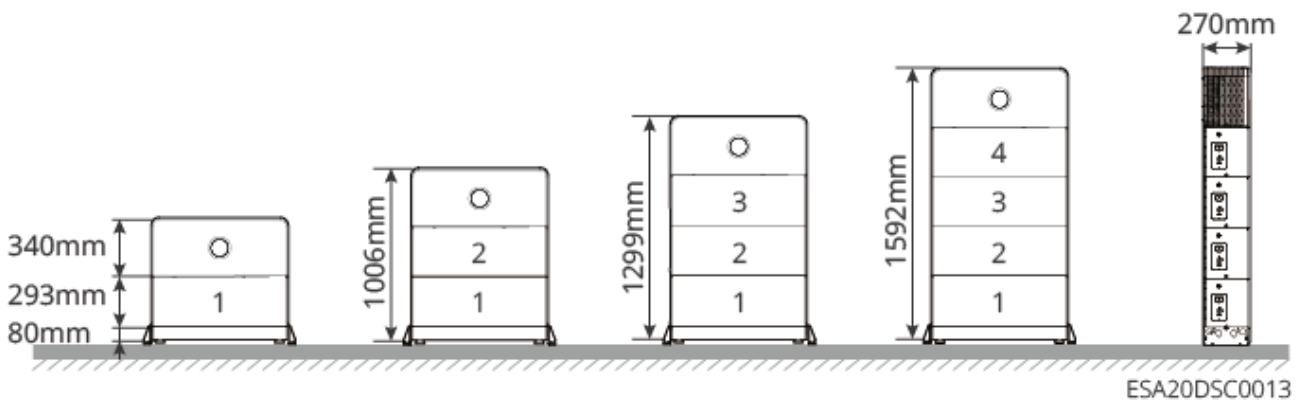

## Cluster Expansion Installation

- Floor-standing Installation

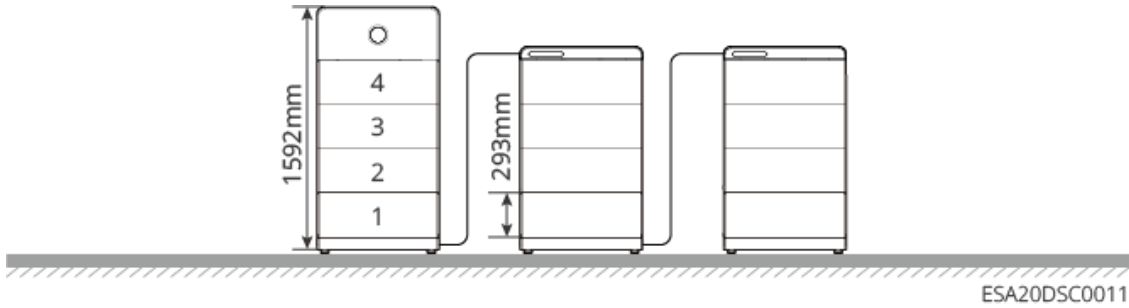

- Wall-mounted Installation

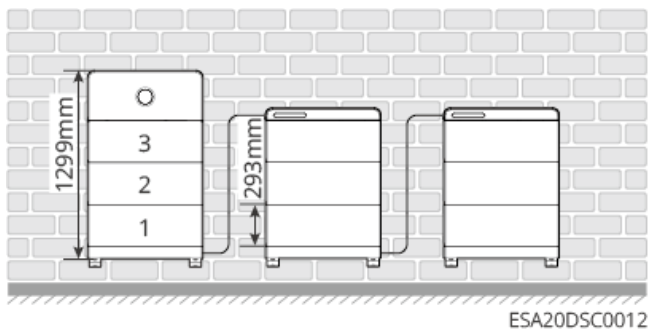

### Inverter:

In a photovoltaic system, the Inverter controls and optimizes the energy flow through an integrated energy management system. It can supply the electricity generated by the PV system to loads, store it in the Battery, or export it to the grid.

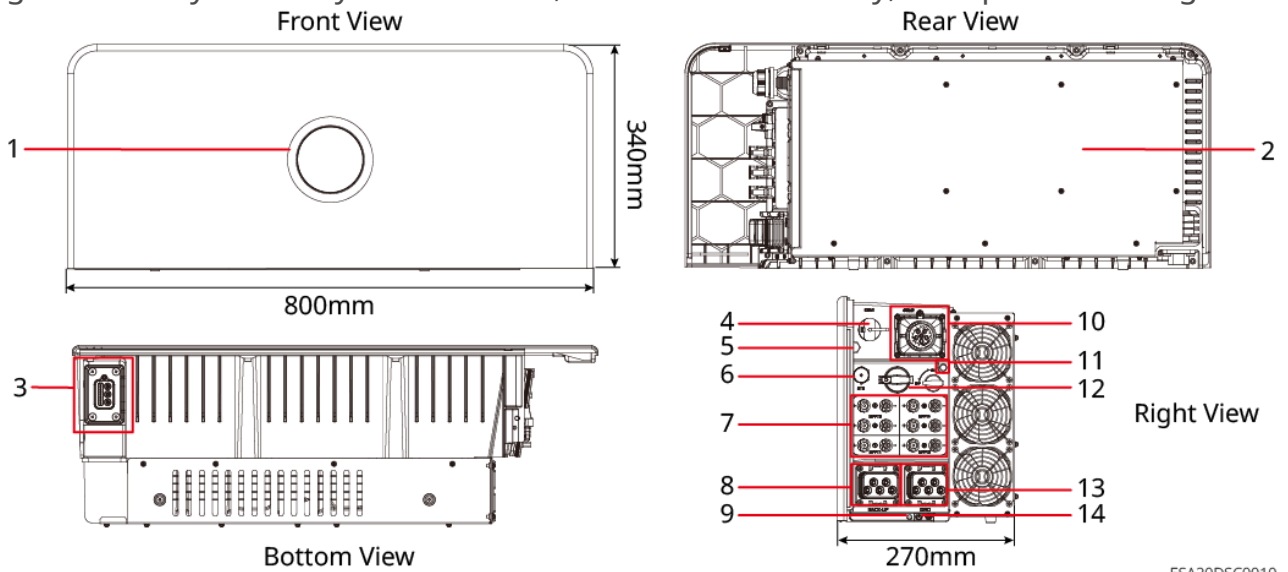

ESA20DSC0010

No.	Component/Silkscreen	Description
1	indicator	Indicates the working status of the inverter.
2	heat sink	Heat dissipation for the inverter.
3	Connector	Power and communication ports for connecting the inverter to the battery.
4	Smart Communication Stick Connection Port	<ul style="list-style-type: none"> <li>• Can connect to smart communication sticks, such as WiFi/LAN communication modules. Please select the module type based on actual requirements.</li> <li>• Supports connecting a USB flash drive for local inverter software version upgrades.</li> </ul>
5	Ventilation valve	-
6	STS Communication Interface	Reserved
7	PV Input Terminal	<p>Only for ETA models. BTA models do not have PV input terminals.</p> <ul style="list-style-type: none"> <li>• Can connect to PV module DC input cables.</li> <li>• The number of PV input terminals is as follows: <ul style="list-style-type: none"> <li>◦ GW5K-ETA-G20, GW6K-ETA-G20, GW8K-ETA-G20: 3</li> <li>◦ GW9.999K-ETA-G20, GW10K-ETA-G20, GW12K-ETA-G20, GW15K-ETA-G20, GW20K-ETA-G20, GW25K-ETA-G20, GW29.999K-ETA-G20, GW30K-ETA-G20: 4</li> </ul> </li> </ul>
8	BACK-UP Port	Connect AC cables to connect critical loads or grid-tie inverters.
9	Battery Mounting Hole	Secures the inverter and the battery.

No.	Component/Silkscreen	Description
10	Communication Port	Can connect communication cables for load control, CT, RS485, Remote Shutdown/Rapid Shutdown, DRED (Australia)/RCR (Europe), etc.
11	Carrying Handle Mounting Hole	Used for installing the carrying handle. Used when moving the inverter.
12	DC Switch	Only for ETA models. BTA models do not have a DC switch. Controls the connection or disconnection of the DC input.
13	GRID Port	Connect AC cables to connect the inverter to the grid.
14	Grounding terminal	Connect the chassis protective ground wire.

**Battery:**

The Battery system can store and release electrical energy according to the requirements of the PV energy storage system. Both the input and output ports of this energy storage system are high-voltage direct current.

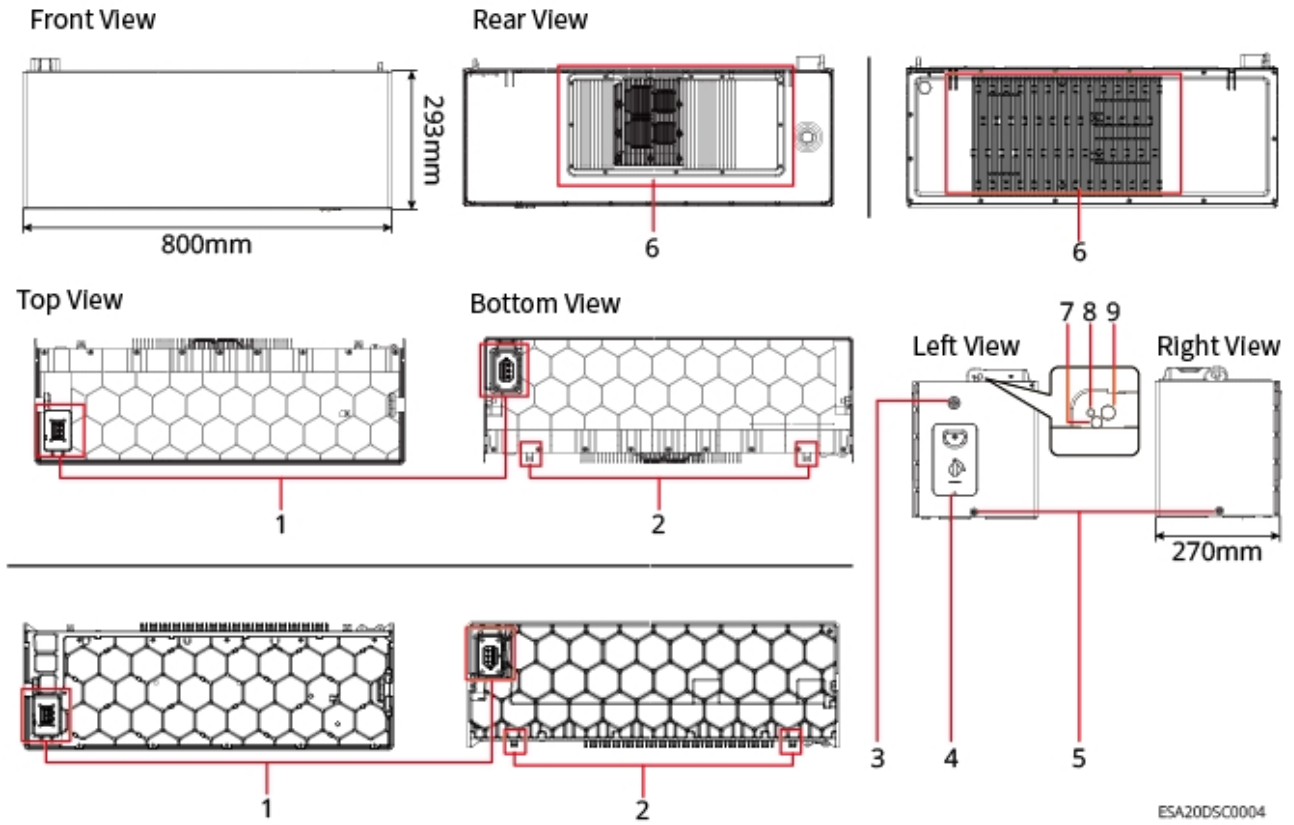

ESA20DSC0004

No.	Component	Description
1	Connector	Power and Communication Port for connecting battery to battery, and battery to inverter.
2	Anti-tip Bracket Mounting Hole	Used for securing the battery to the wall.

No.	Component	Description
3	Multi-function Button/Indicator	<ul style="list-style-type: none"> <li>Indicates the battery operating status.</li> <li>Battery Black Start Function: When there is no power generation from the PV system in the solar setup and the grid is abnormal, the inverter cannot operate normally. In this case, press and hold the multi-function button for 2 seconds to start the battery system, activate the inverter, and put the inverter into off-grid mode, allowing the battery to discharge and supply power to the loads.</li> <li>Battery Power-off Function: Press and hold the multi-function button for &gt;5 seconds to power down the battery system.</li> </ul>
4	Battery Isolation Switch	Battery power input/output switch.
5	Inter-battery Mounting Hole	Used for securing between two batteries.
6	heat sink	Battery heat dissipation
7	Battery Lifting Hole	Used for hoisting the battery. When stacking more than three batteries, hoisting tools must be used for installation.
8	Battery or Inverter Mounting Hole	Used for securing between batteries or between the inverter and the battery.
9	Carrying Bar Mounting Hole	Used for installing the carrying bar. Used during manual handling of the battery.

### 2.2.2 Smart Meter

The Smart Meter measures and monitors electrical data in the photovoltaic energy storage system, such as: voltage, current, frequency, Power Factor, power, etc.

## GM330&GMK330&CT

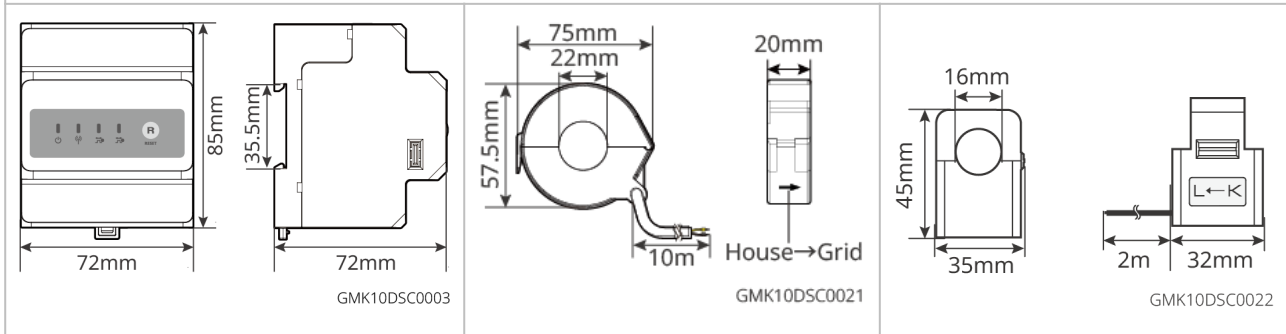

No.	model	Applicable Scenarios
1	GM330	<p>CT can be purchased from GoodWe or separately. CT ratio requirement: nA: 5A</p> <ul style="list-style-type: none"> <li>nA: CT primary side input current, n range is 200-5000</li> <li>5A: CT secondary side output current</li> </ul>
2	GMK330	<p>CT is shipped with the meter. CT ratio:</p> <ul style="list-style-type: none"> <li>120A: 40mA</li> </ul>

### 2.2.3 smart dongle

The smart dongle is mainly used for real-time transmission of various power generation data from inverters to remote monitoring platforms, and for connecting the smart dongle via an App for local device debugging.

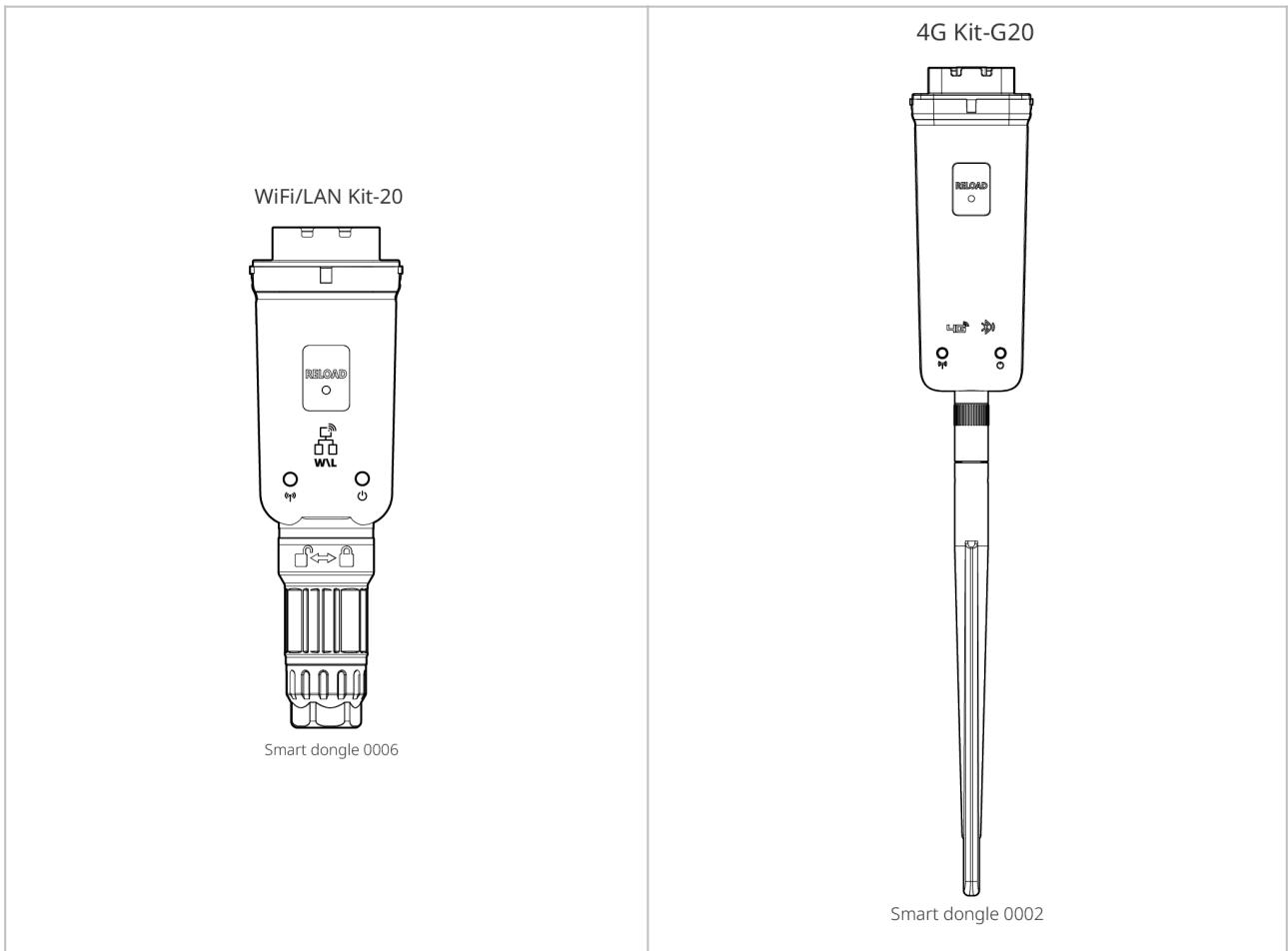

No.	model	Signal Type	Applicable Scenarios
1	WiFi/LAN Kit-20	WiFi, LAN, Bluetooth	Single-unit and multi-unit inverter scenarios
2	4G Kit-G20	4G, Bluetooth	Single-unit inverter scenarios.

## 2.3 Supported Grid Types

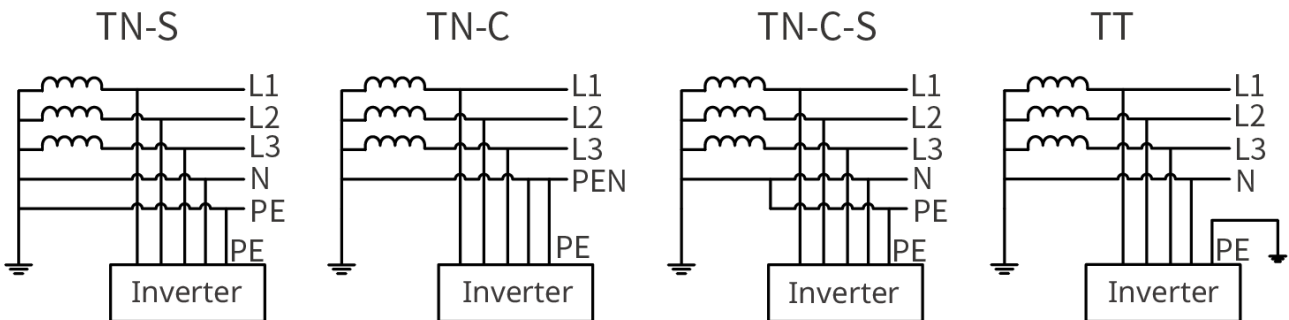

TNNET0003

## 2.4 System Working Mode

### Self-consumption

- The basic operating mode of the system.
- PV-generated electricity is prioritized to power the loads, excess energy charges the battery, and any remaining surplus is sold to the grid. When PV generation cannot meet the load demand, the battery supplies power to the loads; when the battery energy is also insufficient to meet the load demand, the grid supplies power to the loads.

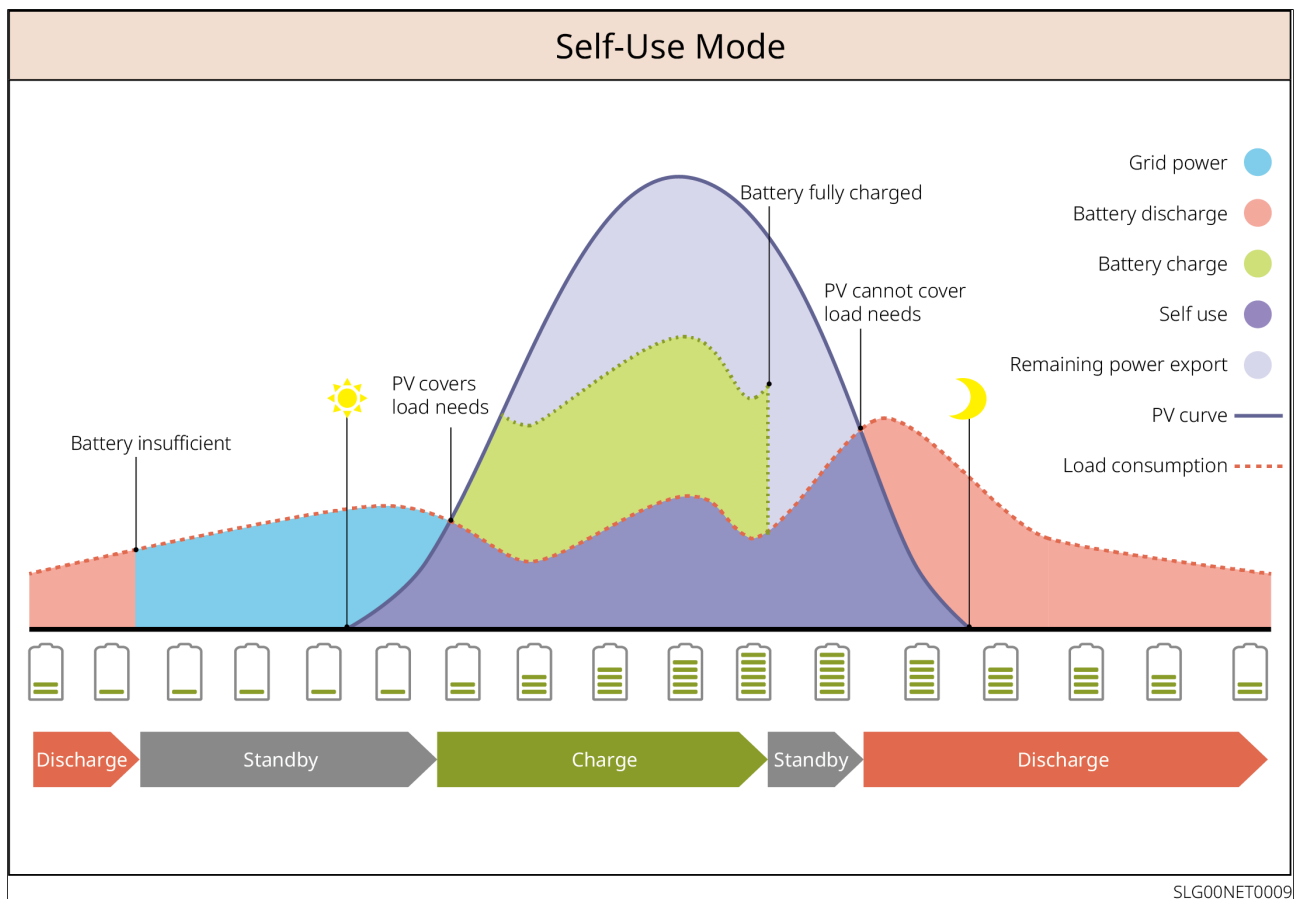

Figure1 Self-consumption

### Backup Mode

- Recommended for areas with unstable grid.
- When the grid fails, the inverter switches to off-grid operation mode, and the

battery discharges to power the loads, ensuring the BACK-UP Loads remain powered; when the grid is restored, the inverter switches back to grid-connected operation.

- To ensure the battery SOC is sufficient to maintain normal system operation during off-grid periods, the system will charge the battery using PV or by purchasing electricity from the grid to the backup power SOC during grid-connected operation. If purchasing electricity from the grid to charge the battery is required, please ensure it complies with local grid regulations.

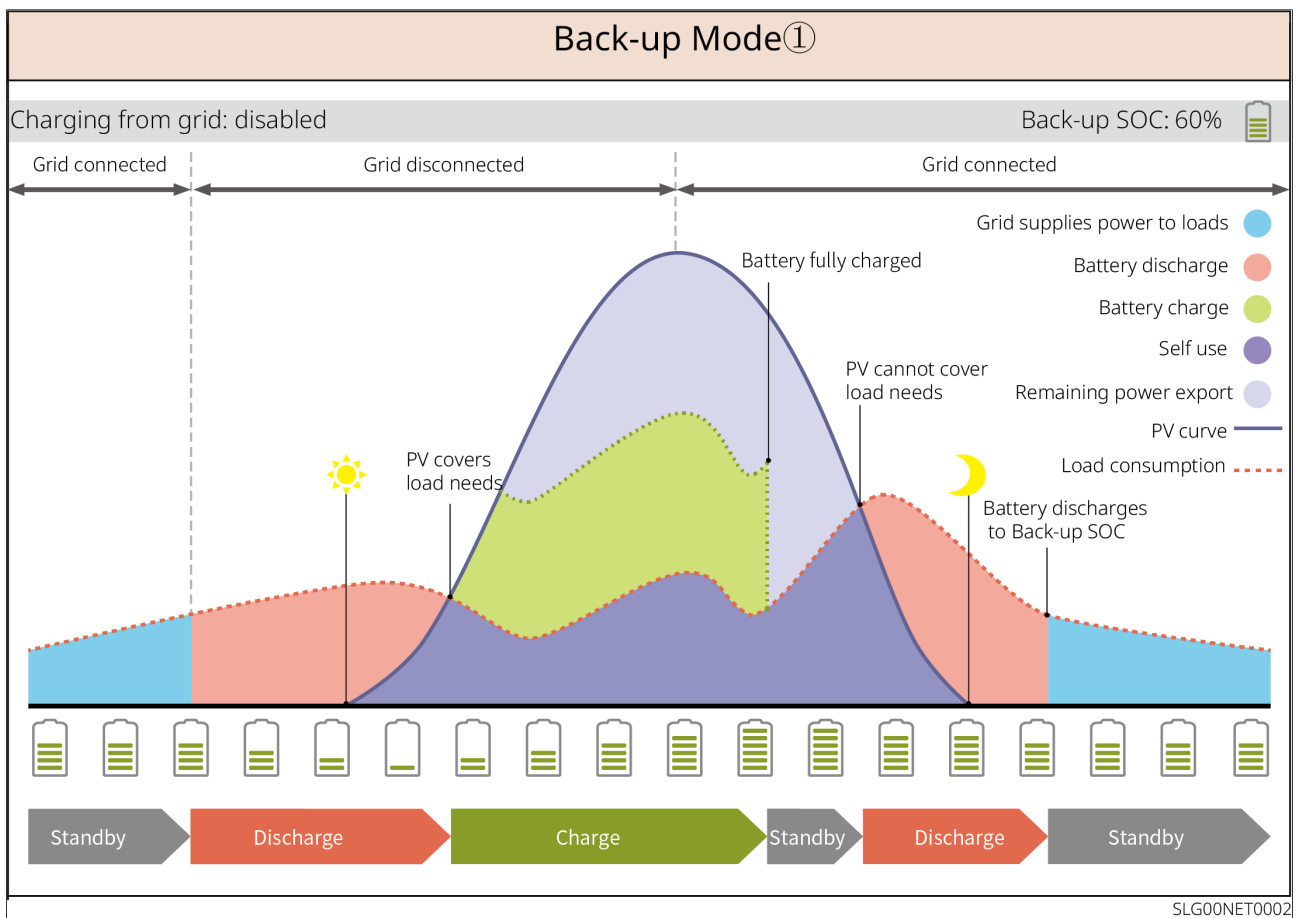

Figure2 Backup Mode 1

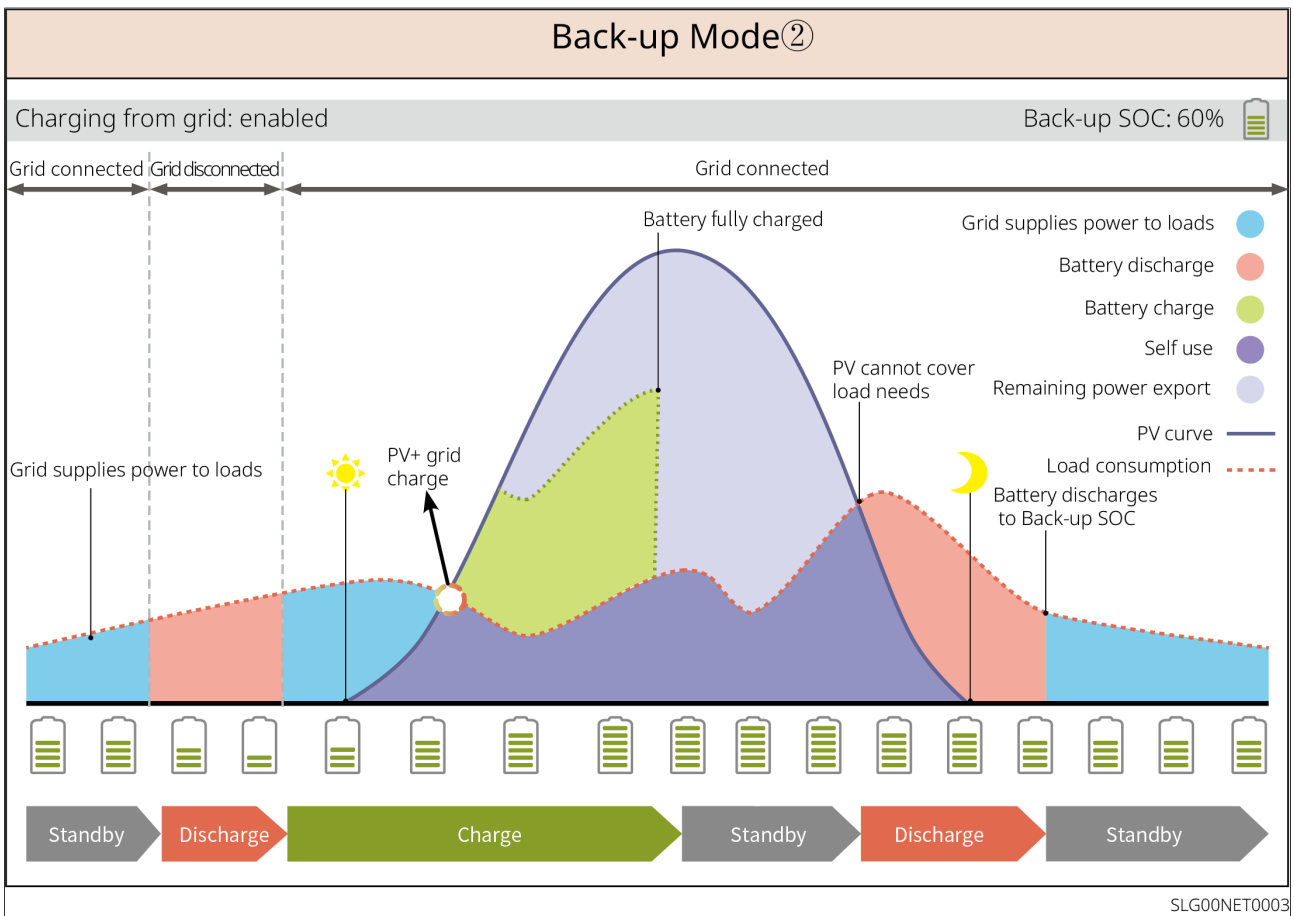

Figure3 Backup Mode 2

### TOU Mode

Subject to compliance with local laws and regulations, buy and sell electricity during different time periods based on the difference between peak and valley electricity prices.

For example: During valley price periods, set the battery to charging mode to purchase electricity from the grid for charging; during peak price periods, set the battery to discharging mode to power the loads via the battery.

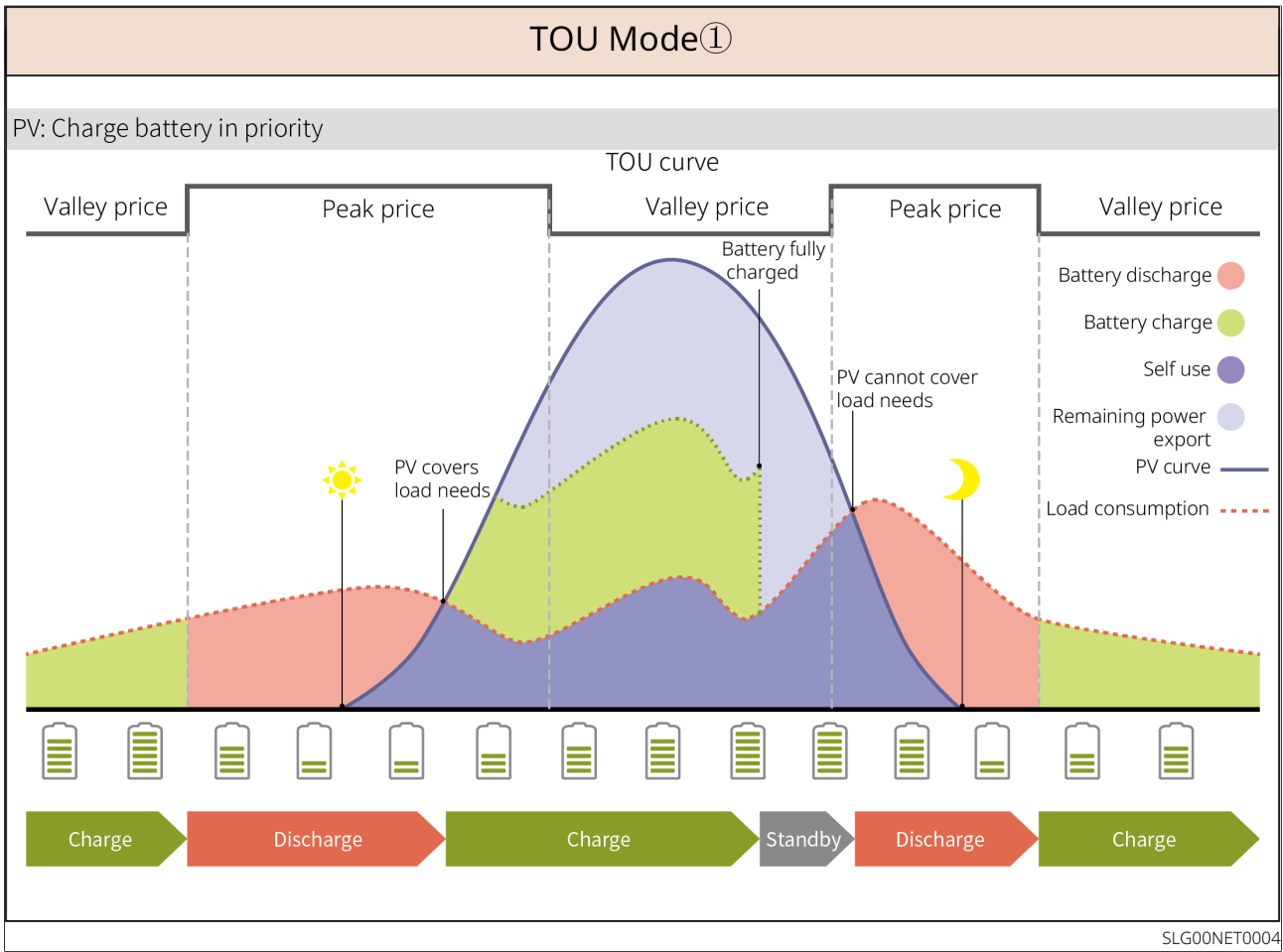

Figure4 TOU Mode 1

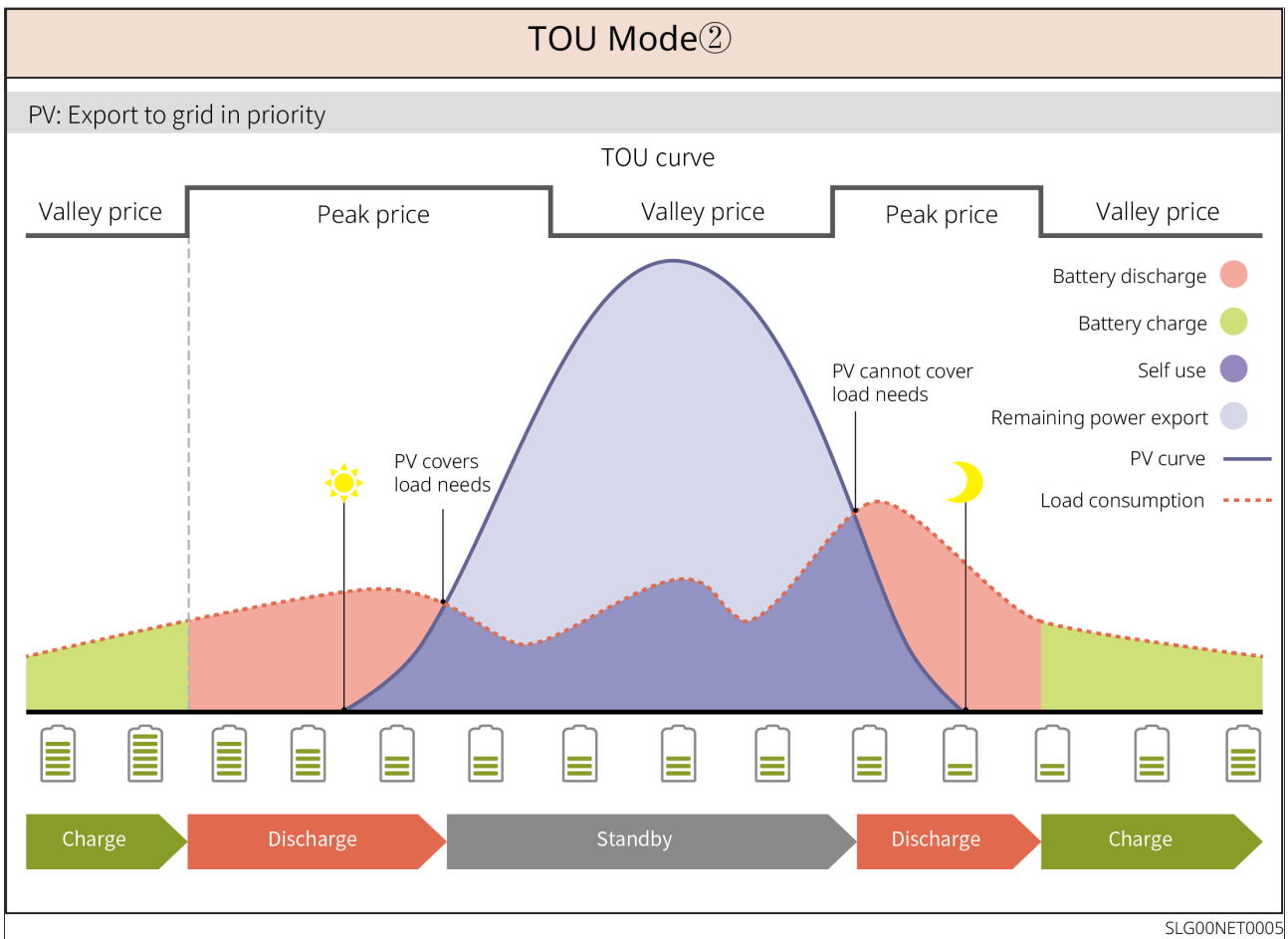

Figure5 TOU Mode 2

### Delayed Charging Mode

- Suitable for areas with grid-connected power output limitations.
- Setting a peak power limit can use PV generation exceeding the grid connection limit to charge the battery; or setting PV charging periods allows using PV generation to charge the battery during those periods.

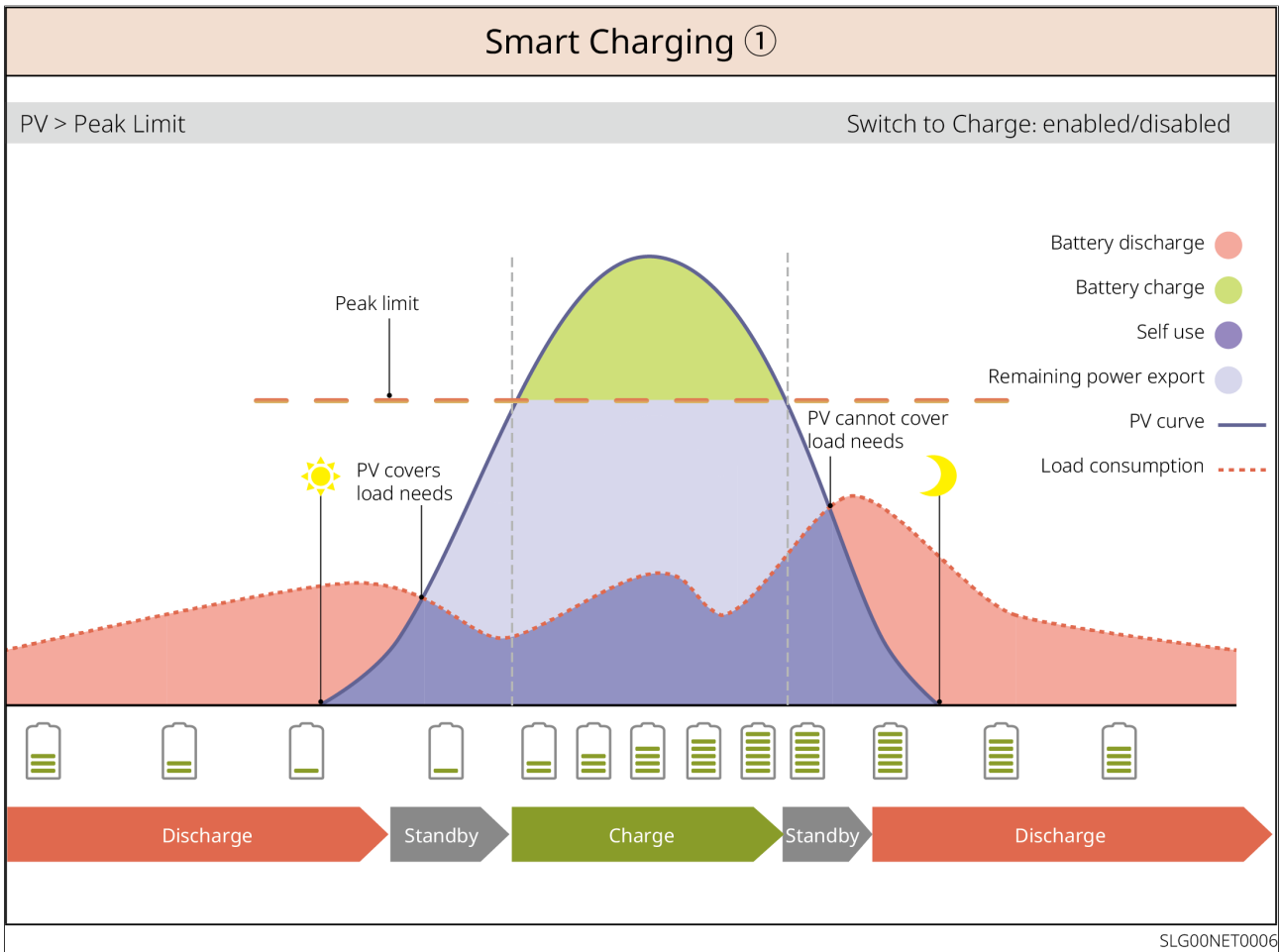

Figure6 Delayed Charging Mode 1

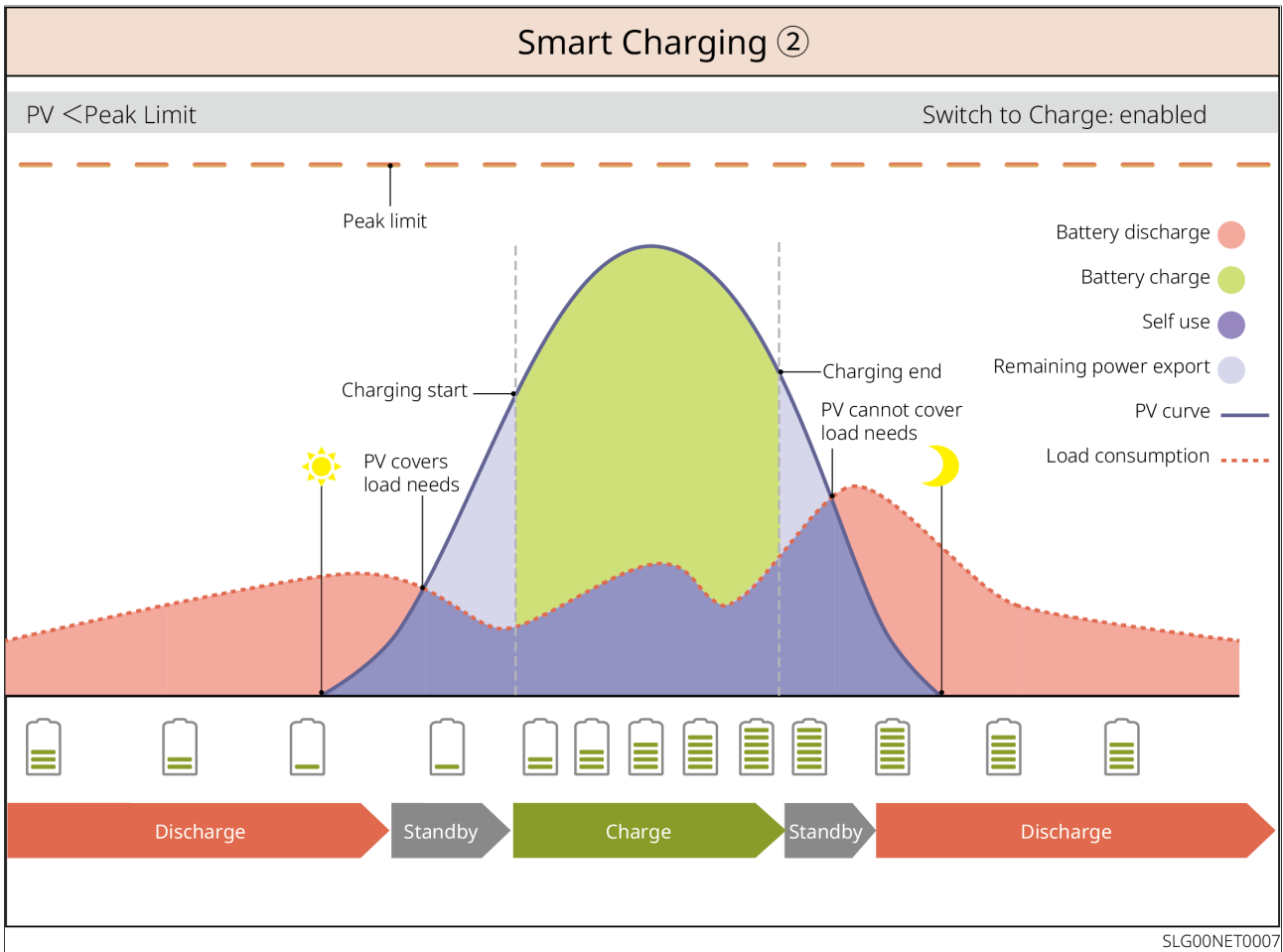

Figure7 Delayed Charging Mode 2

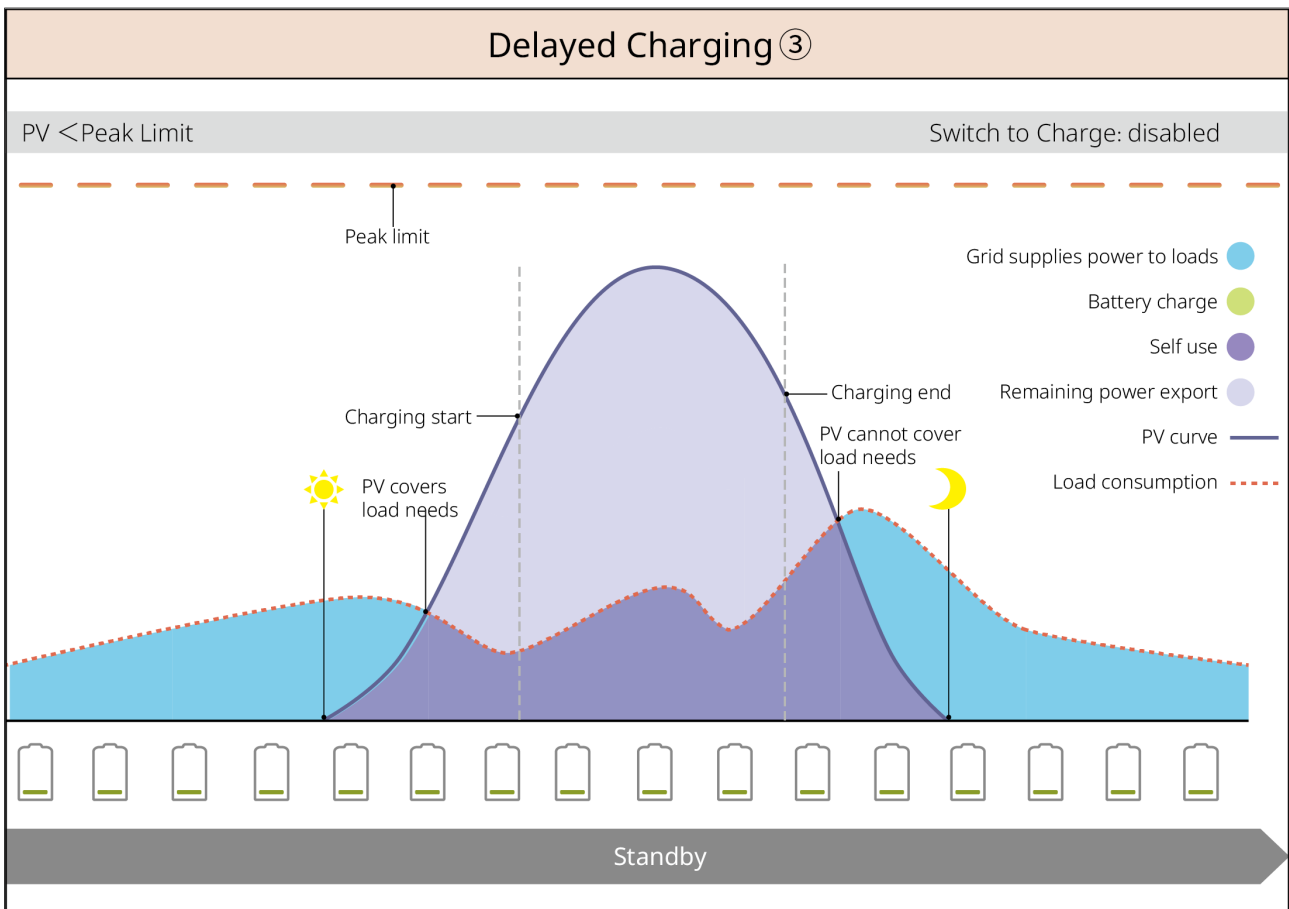

Figure8 Delayed Charging Mode 3

### Peakshaving Mode

- Primarily suitable for commercial and industrial scenarios.
- When the total load power consumption exceeds the electricity quota within a short period, battery discharge can be used to reduce the portion exceeding the quota.
- When the battery SOC is lower than the reserved SOC for peak shaving, the system purchases electricity from the grid based on time periods, load consumption, and peak purchase power limits.

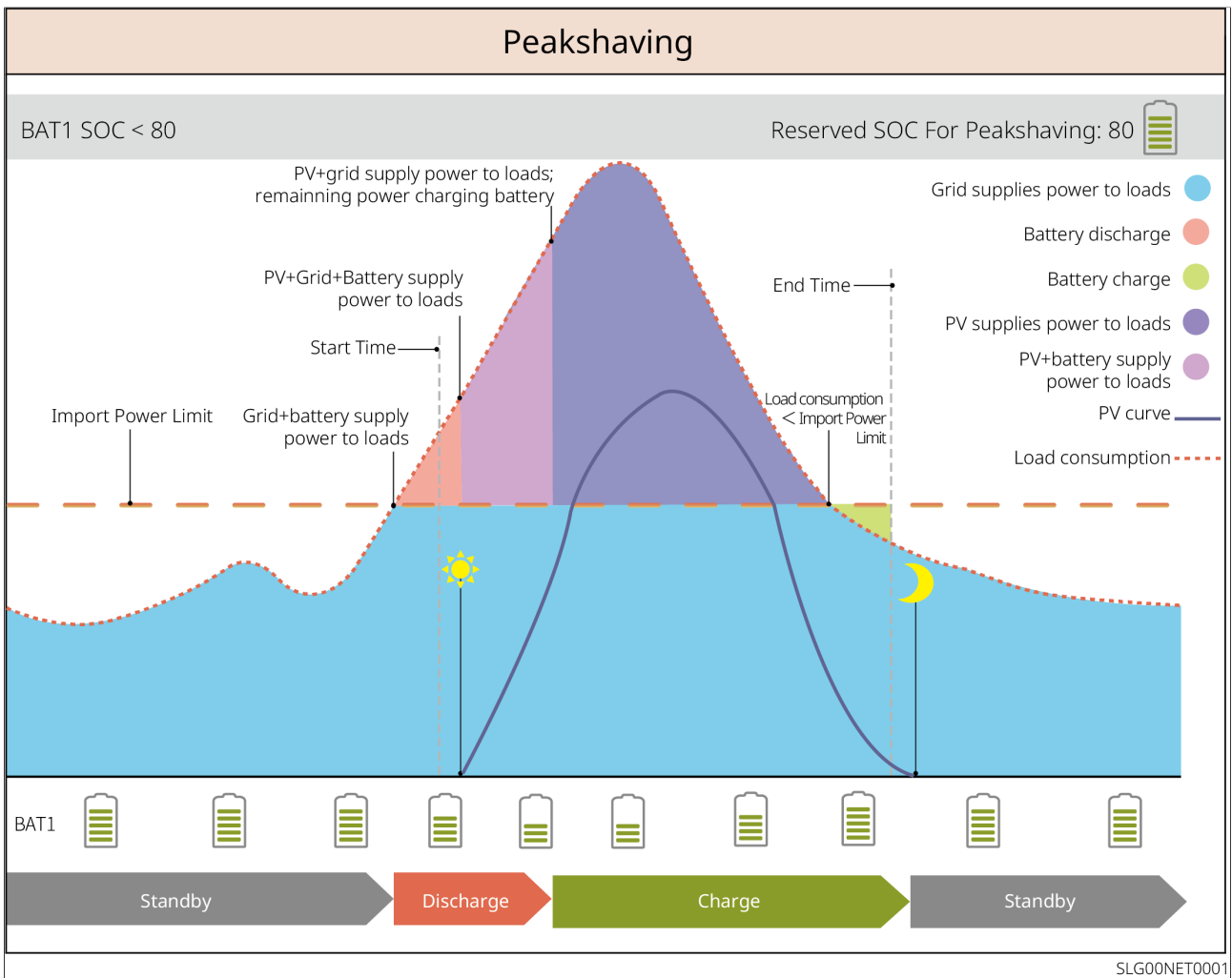

Figure9 Peakshaving Mode

## Off-grid Mode

### NOTICE

Do not operate in pure off-grid mode when the inverter is not connected to the battery system.

When the grid fails, the inverter switches to off-grid operation mode.

- During the day, PV generation is prioritized to power the loads, with excess energy charging the battery.
- At night, the battery discharges to power the loads, ensuring the BACK-UP Loads remain powered.

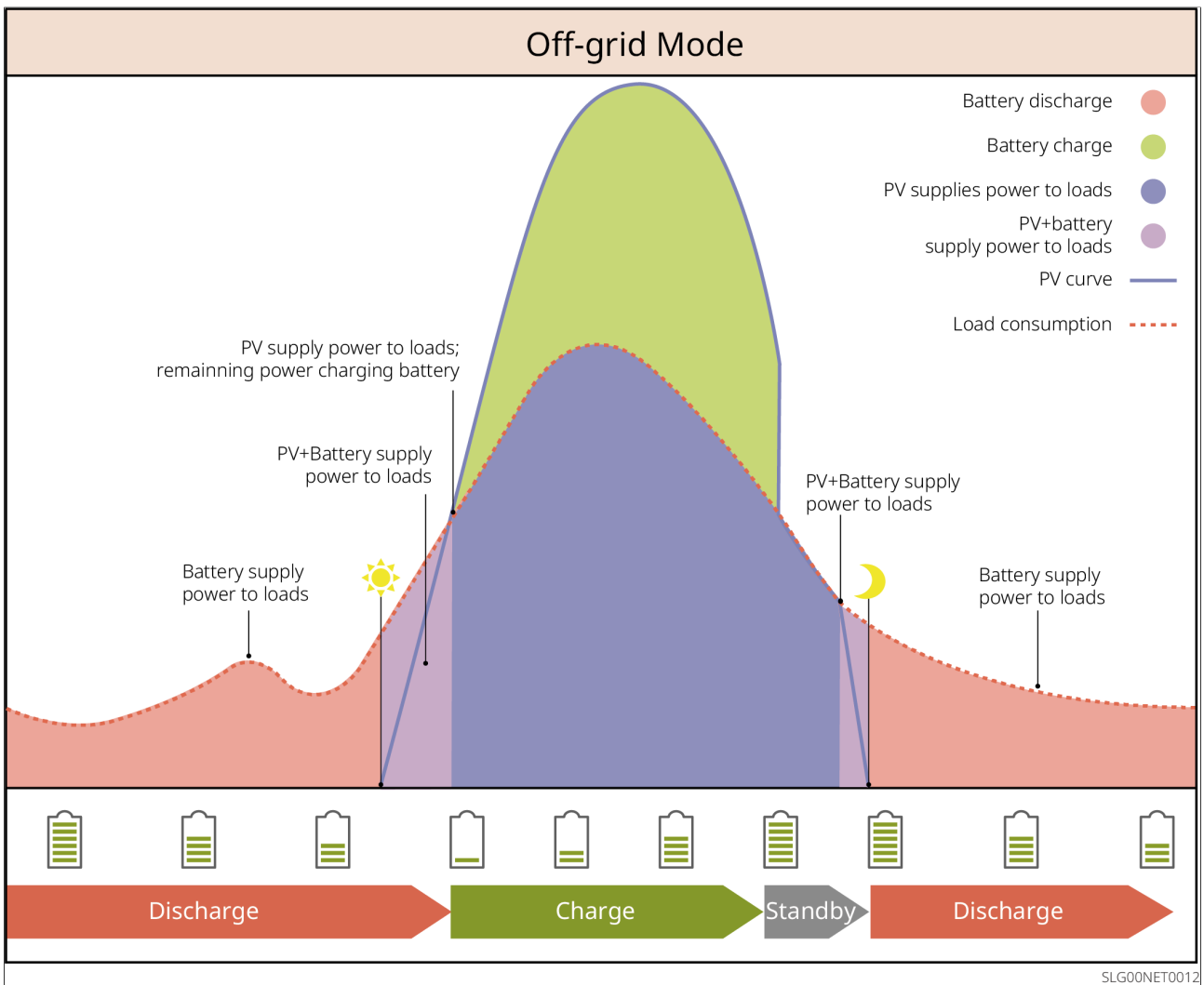

Figure10 Off-grid Mode

## 2.5 Features

### NOTICE

Please refer to the actual product configuration for specific functional features.

#### AFCI

The inverter integrates an AFCI circuit protection device to detect arc faults and quickly cut off the circuit when detected, thereby preventing electrical fires.

Causes of arc generation:

- Damage to connector connections in the PV system.

- Incorrect or damaged cable connections.
- Aging of connectors or cables.

Fault handling methods:

1. When the inverter detects an arc, you can view the fault type via the App.
2. If the inverter triggers a fault <5 times within 24 hours, it will automatically restore grid connection after a 5-minute wait. After the 5th arc fault, the fault must be cleared before the inverter can resume normal operation. For specific operations, please refer to the *SEMS+ App User Manual*.

model	Label	Description
GW5K-ETA-G20 GW6K-ETA-G20 GW8K-ETA-G20	AFCI: F-I-AFPE-1-2/1-2	<p>F (Full coverage) : Full coverage of inverter PV input ports</p> <p>I (Integrated) : Integrated within the inverter</p> <p>AFPE (arc fault protection equipment) : Combines both AFD and AFI arc detection functions</p> <p>1: One pair of PV input ports (PV+, PV-) connects to one PV input string</p> <p>2/1: One arc detection channel has 2 MPPT inputs; One arc detection channel has 1 MPPT input;</p> <p>2: Has 2 arc detection channels</p>

model	Label	Description
GW9.999K-ETA-G20 GW10K-ETA-G20 GW12K-ETA-G20 GW15K-ETA-G20 GW20K-ETA-G20	AFCI: F-I-AFPE-1-2/2-2	F (Full coverage) : Full coverage of inverter PV input ports I (Integrated) : Integrated within the inverter AFPE (arc fault protection equipment) : Combines both AFD and AFI arc detection functions 1: One pair of PV input ports (PV+, PV-) connects to one PV input string 2/2: Each arc detection channel has 2 MPPT inputs; 2: Has 2 arc detection channels
GW25K-ETA-G20 GW29.999K-ETA-G20 GW30K-ETA-G20	AFCI: F-I-AFPE-1-2/4-2	F (Full coverage) : Full coverage of inverter PV input ports I (Integrated) : Integrated within the inverter AFPE (arc fault protection equipment) : Combines both AFD and AFI arc detection functions 1: One pair of PV input ports (PV+, PV-) connects to one PV input string 2/4: One arc detection channel has 2 MPPT inputs; One arc detection channel has 4 MPPT inputs; 2: Has 2 arc detection channels

### Three-Phase Unbalanced Output

Both the grid-tie side and the BACK-UP side of the inverter support three-phase unbalanced output, allowing connection of loads with different power ratings to each phase. The maximum output power per phase for different models is shown in the table below:

No.	model	Single-Phase Maximum Output Power
1	GW5K-ETA-G20 GW5K-BTA-G20	2.5kW
2	GW6K-ETA-G20 GW6K-BTA-G20	3kW
3	GW8K-ETA-G20 GW8K-BTA-G20	4kW
4	GW9.999K-ETA-G20 GW9.999K-BTA-G20	5kW
5	GW10K-ETA-G20 GW10K-BTA-G20	5kW
6	GW12K-ETA-G20 GW12K-BTA-G20	6kW
7	GW15K-ETA-G20 GW15K-BTA-G20	7.3kW
8	GW20K-ETA-G20 GW20K-BTA-G20	7.3kW
9	GW25K-ETA-G20 GW25K-BTA-G20	11kW
10	GW29.999K-ETA-G20 GW29.999K-BTA-G20	11kW
11	GW30K-ETA-G20 GW30K-BTA-G20	11kW

#### Rapid Shutdown (RSD) Rapid Shutdown

In a rapid shutdown system, the rapid shutdown transmitter and receiver work together to achieve rapid system shutdown. The receiver maintains module output by receiving signals from the transmitter. The transmitter can be external or built into the inverter. In case of an emergency, the transmitter can be deactivated by enabling an external trigger device, thereby shutting down the modules.

- External Transmitter
  - Transmitter models: GTP-F2L-20, GTP-F2M-20  
<https://en.goodwe.com/Ftp/Installation-instructions/RSD2.0-transmitter.pdf>
  - Receiver models: GR-B1F-20, GR-B2F-20

[https://en.goodwe.com/Ftp/EN/Downloads/User%20Manual/GW\\_RSD-20\\_Quick-Installation-Guide-POLY.pdf](https://en.goodwe.com/Ftp/EN/Downloads/User%20Manual/GW_RSD-20_Quick-Installation-Guide-POLY.pdf)

- Built-in Transmitter
  - External trigger device: External switch
  - Receiver models: GR-B1F-20, GR-B2F-20

[https://en.goodwe.com/Ftp/EN/Downloads/User%20Manual/GW\\_RSD-20\\_Quick-Installation-Guide-POLY.pdf](https://en.goodwe.com/Ftp/EN/Downloads/User%20Manual/GW_RSD-20_Quick-Installation-Guide-POLY.pdf)

# 3 Check and Storage

## 3.1 Check Before Receiving

Before receiving the product, please carefully check the following:



1. Check if the outer packaging is damaged, such as deformation, holes, cracks, or other signs that could cause damage to the equipment inside the box. If damaged, do not open the packaging and contact your dealer.
2. Check if the device model is correct. If it does not match, do not open the packaging and contact your dealer.



## 3.2 deliverables

 **WARNING**

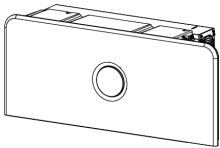
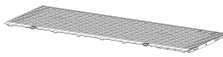
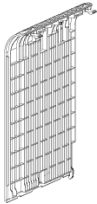
Check if the type and quantity of the delivered items are correct, and if there is any damage to the appearance. If there is any damage, please contact your dealer. After removing the delivered items from the packaging, do not place them on rough, uneven, or sharp surfaces to avoid paint chipping.

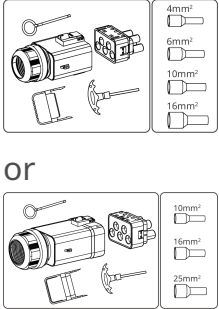
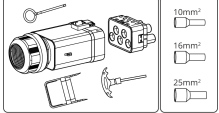
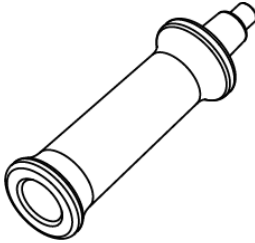
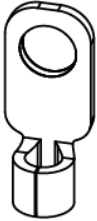
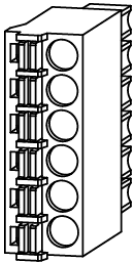
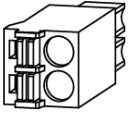

### 3.2.1 Inverter Deliverables

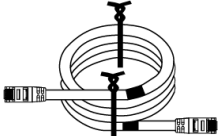
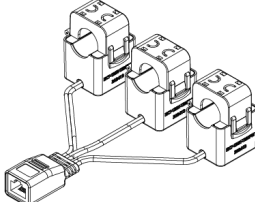
Part	Description	Part	Description
	Inverter x 1		Top decorative cover x 1
	Left decorative cover x 1		Right decorative cover x 1

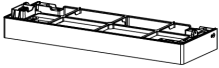
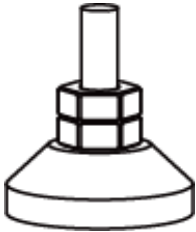
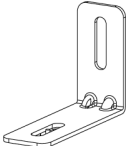
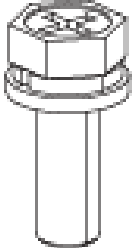
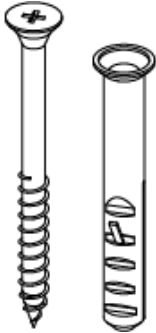
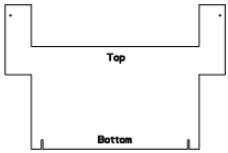
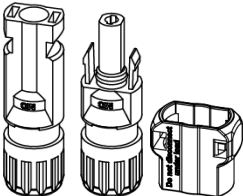
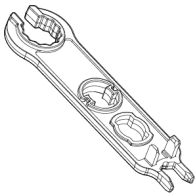
Part	Description	Part	Description
 <p>or</p> 	<p>AC terminal kit x 2</p> <ul style="list-style-type: none"> <li>• AC wiring terminal x 2</li> <li>• PIN terminal x N <ul style="list-style-type: none"> <li>◦ 5-20kW: <ul style="list-style-type: none"> <li>▪ 4mm<sup>2</sup> x 5</li> <li>▪ 6mm<sup>2</sup> x 5</li> <li>▪ 10mm<sup>2</sup> x 5</li> <li>▪ 16mm<sup>2</sup> x 5</li> </ul> </li> <li>◦ 25-30kW: <ul style="list-style-type: none"> <li>▪ 10mm<sup>2</sup> x 5</li> <li>▪ 16mm<sup>2</sup> x 5</li> <li>▪ 25mm<sup>2</sup> x 5</li> </ul> </li> </ul> </li> </ul>		<p>Handle x 2</p>
	<p>OT grounding terminal x 1</p>		<p>6PIN communication terminal x 2</p>
	<p>2PIN communication terminal x 2</p>		<p>PIN terminal x 16</p>
	<p>CT connection cable x 1</p>		<p>CT x 1</p>

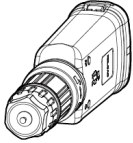
Part	Description	Part	Description
	Battery base x 1		Adjustable feet x 4
	Anti-tip bracket x 4		M5*16 screw x 9
	M5*60 expansion screw x 4		Drilling template paper x 2
			PV terminal unlocking tool x N N: China region x 0; other regions x 1.

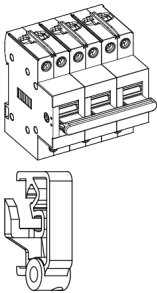
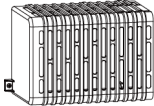
Part	Description	Part	Description
	<p>PV terminal and PV terminal anti-removal cover</p> <ul style="list-style-type: none"> <li>• GW5K-ETA-G20, GW6K-ETA-G20, GW8K-ETA-G20, GW6K-EHA-G20: 3</li> <li>• GW9.999K-ETA-G20, GW10K-ETA-G20, GW12K-ETA-G20, GW15K-ETA-G20, GW20K-ETA-G20, GW25K-ETA-G20, GW29.999K-ETA-G20, GW30K-ETA-G20: 4</li> <li>• GW5K-BTA-G20, GW6K-BTA-G20, GW8K-BTA-G20, GW9.999K-BTA-G20, GW10K-BTA-G20, GW12K-BTA-G20, GW15K-BTA-G20, GW20K-BTA-G20, GW25-BTA-G20, GW29.999K-BTA-G20, GW30K-BTA-G20: 0</li> </ul>		<p>Smart dongle x 1</p>

Part	Description	Part	Description
	<ul style="list-style-type: none"> <li>• (Australia only) Manual transfer switch x1</li> <li>• Manual transfer switch lock x N</li> </ul> <p>Note: For single-unit scenarios only</p>		<p>Cable cover x N</p> <p>N: Standard in Australia region; optional in Europe region.</p>
	<p>Product documentation x 1</p>	-	-

**(Europe only) Manual transfer switch**

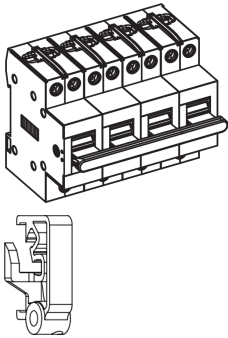

Part	Description
	<ul style="list-style-type: none"> <li>• Manual transfer switch x1</li> <li>• Manual transfer switch latch x1</li> </ul> <p>Note: For use in single-unit scenarios only. If needed, please contact the distributor to purchase.</p>

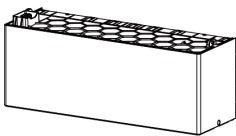
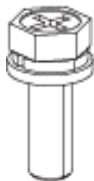
**3.2.2 Batteries Deliverables**

Component	Instructions	Component	Description
	<p>Battery x 1</p>		<p>M5*16 screw x 2</p>

Component	Instructions	Component	Description
	silica gel cap x 2	-	-

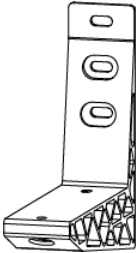
Bracket (Optional)







Component	Instructions	Component	Instructions
	mounting bracket x 2		M10x 6
	M10x 4	-	-

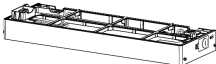
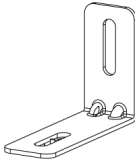

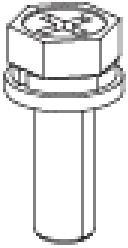
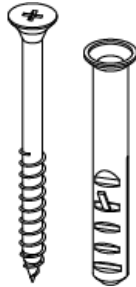
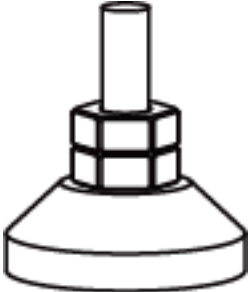
3.2.2.1 Battery Expansion Kit deliverables (Optional)

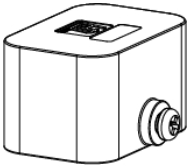
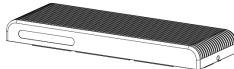
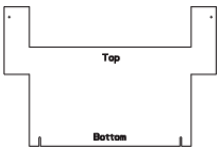
**NOTICE**

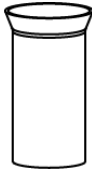
The system supports 5-108kWh. A single string can stack up to 6 Battery units. If more energy is required, or if the stacking height per string needs to be reduced due to Installation conditions or other expansion scenarios, please contact GoodWe or a distributor to purchase the Battery expansion kit.

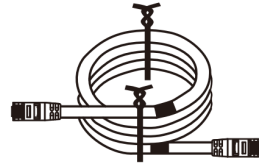
Component	Instructions	Component	Instructions
	Base x 1		locking bracket x 4

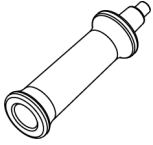
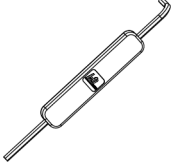
Component	Instructions	Component	Instructions
	M5 x 7		M6 x 4
	Adjustable feet x 4		OT Grounding terminal x 1
	Terminal resistor x 1		Decorative cover x 1
	Punching mark paper x 2		Expansion cluster harness x 1
	PIN terminal x 8		Expansion cluster connection positive harness x 1
	Expansion cluster connection negative harness x 1		Expansion cluster network cable x 1





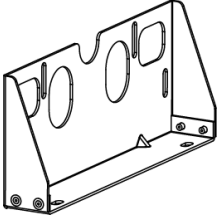
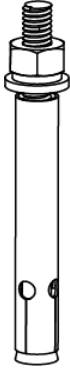
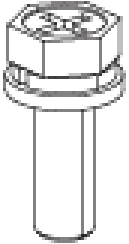

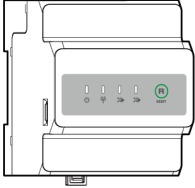

Component	Instructions	Component	Instructions
	silica gel cap x 2		Handle x 2
	Hex key wrench x 1		Product Documentation x 1

### 3.2.2.2 Floor-Mounted Standoff Bracket (Optional)

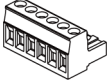
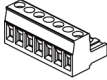
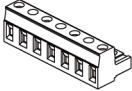
Part	Description	Part	Description
	Floor-Mounted Standoff Bracket x 2		M6 expansion bolts x 4
	M5 mounting screws x 4	-	-

### 3.2.3 Smart Meter Delivery Set GM330&GMK330

#### 3.2.3.1 Attachment List

Component	Instructions	Component	Instructions
	Smart Meterx1 GMK330:CT×3; GMK360: CT×6; GM330: CT x 0。		2PIN connector x1 Applicable to GM330.
	6PIN communication terminal x1 Applicable to GM330.		7PINcommunication terminal x1 Applicable to GM330.
	Electricity meter Applicable to GMK330/GMK360.		RS485communication terminal x 1
	2PINterminal andRJ45terminal adapter cable x 1		screwdriver x1
	PIN terminal GMK330/GMK360: x 5 ; GM330: x 6。		Product Documentation x 1

### 3.3 Storage

- If the inverter has been stored for more than two years or has not been operated for more than six months after installation, it is recommended to have it inspected and tested by a professional before putting it into use.
- To ensure the good electrical performance of the internal electronic components of the inverter, it is recommended to power it on once every six months during storage. If it has not been powered on for more than six months, it is recommended to have it inspected and tested by a professional before use.
- To ensure battery performance and service life, it is recommended to avoid long-term idle storage. Prolonged storage may cause the battery to deep discharge, leading to irreversible chemical degradation, resulting in capacity decay or even complete failure, timely use is advised. If the battery needs to be stored for a long

period, please perform maintenance according to the following requirements:

### NOTICE

[1] The storage time is calculated from the SN date on the battery's outer packaging. After exceeding the storage cycle, charge-discharge maintenance is required. (Battery maintenance time = SN date + charge-discharge maintenance cycle). For how to view the SN date, refer to: [10.3.Battery SN Code Meaning\(Page 306\)](#).

[2] After the charge-discharge maintenance is qualified, if there is a Maintaining Label on the outer box, please update the maintenance information on the Maintaining Label. If there is no Maintaining Label, please record the maintenance time and battery SOC yourself and keep the data properly for maintaining maintenance records.

Battery Model	Initial SOC Range for Battery Storage	Recommended Storage Temperature	Charge/Discharge Maintenance Cycle <sup>[1]</sup>	Battery Maintenance Method <sup>[2]</sup>
GW5.1-BAT-D-G20	30~40%	0~35°C	-20~35°C, 12 months 35~45°C, 6 months	For maintenance methods, please consult the distributor or after-sales service center.
GW8.3-BAT-D-G20				
GW5.1-BAT-D-G21				
GW8.3-BAT-D-G21				
GW6.0-BAT-D-G20	30~40%	0~35°C	-20~35°C, 12 months 35~45°C, 6 months 45~55°C, 1 month	
GW9.0-BAT-D-G20				

#### Packaging Requirements:

Ensure the outer packaging box is not removed and the desiccant inside the box is not missing.

## Environmental Requirements:

1. Ensure the device is stored in a cool place, avoiding direct sunlight.
2. Ensure the storage environment is clean, with appropriate temperature and humidity ranges, and no condensation. If condensation is observed on the device ports, do not install the device.
  - GW5.1-BAT-D-G20, GW8.3-BAT-D-G20, GW5.1-BAT-D-G21, GW8.3-BAT-D-G21 battery storage humidity range: 5%-95%.
  - GW6.0-BAT-D-G20, GW9.0-BAT-D-G20 battery storage humidity range: 4%-100%.
3. Ensure the device is stored away from flammable, explosive, corrosive, and other hazardous materials.
4. Stacking Requirements:
  - Ensure the stacking height and orientation of the device are arranged according to the instructions on the packaging box label.
  - Ensure there is no risk of toppling after the devices are stacked.

# 4 Installation

## DANGER

When performing equipment installation and electrical connections, please use the delivery items shipped with the box. Otherwise, any resulting equipment damage will not be covered under warranty.

## 4.1 Installation Requirements

### 4.1.1 Installation Environment Requirements

#### NOTICE

- Inverter operating temperature range: -35°C to 60°C.
- GW5.1-BAT-D-G20, GW8.3-BAT-D-G20: Charging temperature range: -18°C to 55°C; Discharging temperature range: -20°C to 55°C. If installed in an environment below -18°C, the battery will be unable to recharge and recover energy after being depleted, resulting in battery undervoltage protection.
- GW5.1-BAT-D-G21, GW8.3-BAT-D-G21: Charging temperature range: 2°C to 55°C; Discharging temperature range: -20°C to 55°C. If installed in an environment below 2°C, the battery will be unable to recharge and recover energy after being depleted, resulting in battery undervoltage protection.
- GW6.0-BAT-D-G20, GW9.0-BAT-D-G20: Charging temperature range: -20°C to 55°C; Discharging temperature range: -20°C to 55°C. If installed in an environment below -20°C, the battery will be unable to recharge and recover energy after being depleted, resulting in battery undervoltage protection.

1. The device must not be installed in flammable, explosive, corrosive, or similar environments.
2. The temperature and humidity of the installation environment must be within a suitable range.
3. The installation location should be out of reach of children and avoid being placed in easily accessible positions.
4. The device surface may become hot during operation to prevent burns.

5. The device should avoid installation environments with direct sunlight, rain, snow accumulation, etc. It is recommended to install it in a sheltered location, and if necessary, a sunshade can be built.
6. The installation space must meet the ventilation, heat dissipation, and operational space requirements of the device.
7. The installation environment must meet the protection level of the device. Inverter, battery, and smart communication stick are suitable for indoor and outdoor installation; the meter is suitable for indoor installation.
8. The installation height of the device should facilitate operation and maintenance, ensuring that device indicators, all labels are easily visible, and terminals are easy to operate.
9. The installation altitude of the device should be below the maximum operating altitude.
10. Before installing the device outdoors in salt damage areas, consult the device manufacturer. Salt damage areas mainly refer to areas within 500m of the coast. The affected areas are related to sea breeze, precipitation, terrain, etc.
11. The device emits noise during operation. The installation location should be away from areas sensitive to noise, such as residential living areas, schools, hospitals, etc., to avoid disturbing people living in the nearby environment with the noise generated during device operation.
12. Stay away from strong magnetic field environments to avoid electromagnetic interference. If there are wireless radio stations or wireless communication devices below 30MHz near the installation location, install the device according to the following requirements:
  - Inverter: Add a ferrite core with multiple windings at the DC input line or AC output line of the inverter, or add a low-pass EMI filter; or the distance between the inverter and the wireless electromagnetic interference device exceeds 30m
  - Other devices: The distance between the device and the wireless electromagnetic interference device exceeds 30m.

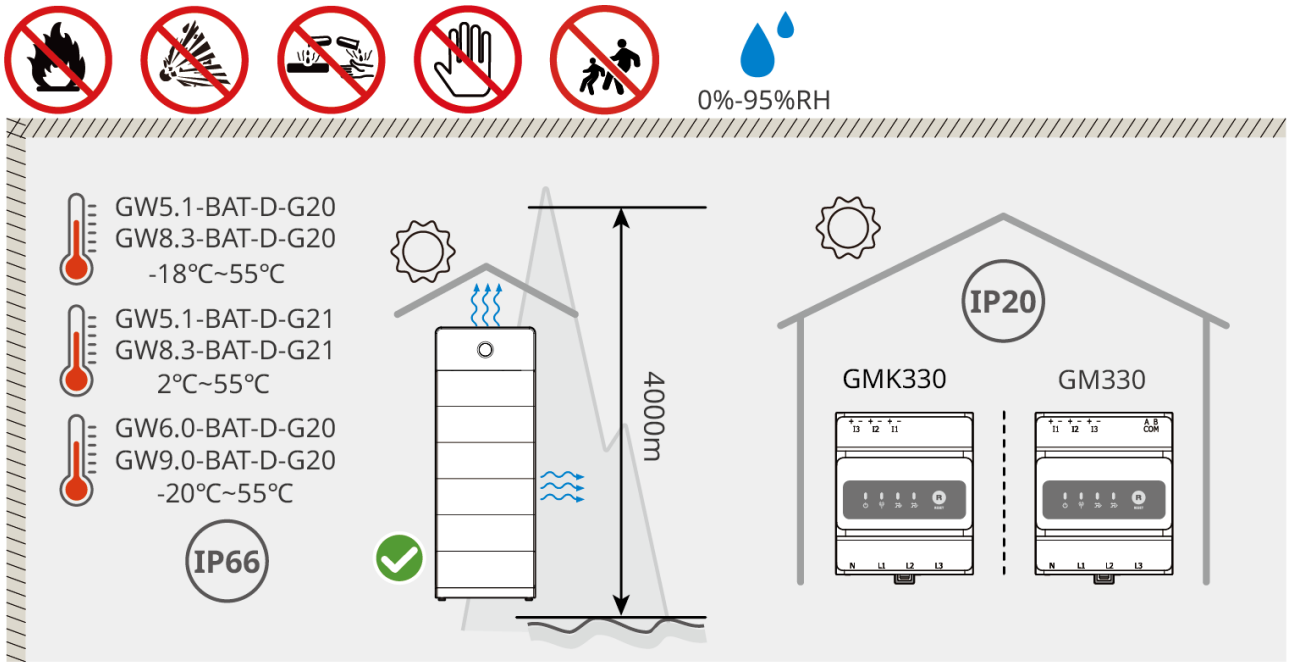

ESA20INT0011

#### 4.1.2 Installation Space Requirements

When installing devices in the system, sufficient space should be reserved around the devices to ensure adequate installation and heat dissipation space.

- When using CAT 7E communication cables between inverters, the cable distance should not exceed 10 meters; when using CAT 5E or CAT 6E communication cables, the cable distance should not exceed 5 meters. Do not exceed 10m for communication cables, otherwise it may cause communication abnormalities.
- For installing CT, use CAT 5E or above shielded network cables, with a cable distance not exceeding 30 meters.
- For RS485 twisted-pair shielded cables used for communication between the inverter and the meter, the cable distance should not exceed 100 meters.



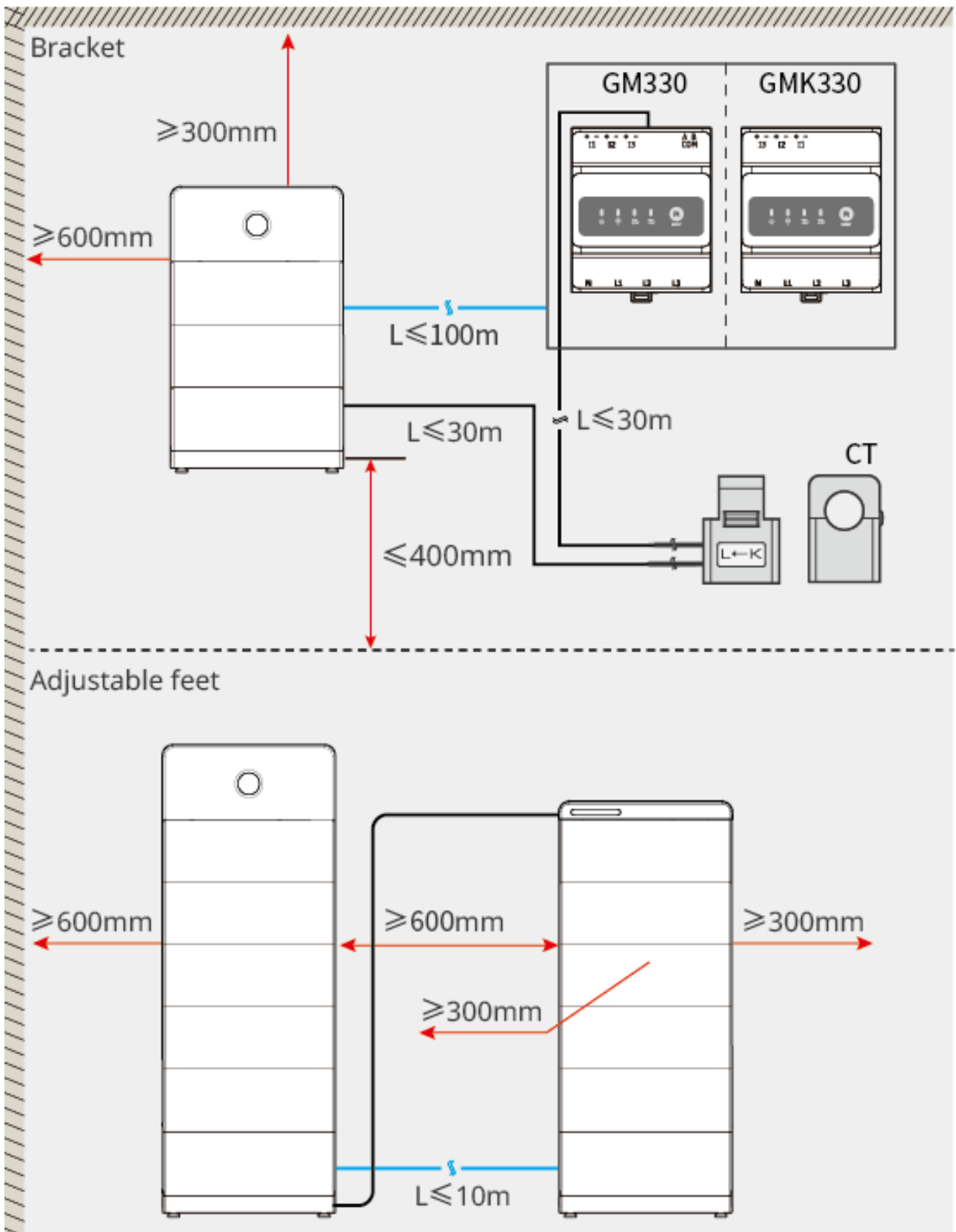



#### Communication Cable Length

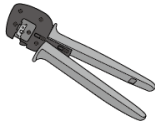

ESA20INT0012

## Installation Space

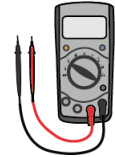
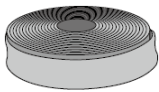

Tool Type	Description	Tool Type	Description
	wire stripper		Level bar
	open-end wrench		PV terminal crimping tool PV-CZM-61100
	hammer drill (drill bit Φ12mm)		torque wrench M4, M5, M6, M10
	rubber hammer		socket wrench
	marker pen		multimeter Range ≤ 1000V
	heat shrink tubing		heat gun
	cable tie		vacuum cleaner

### Personal Protective Equipment

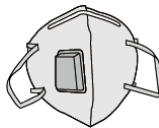
Tool Type	Description	Tool Type	Description
	Insulated gloves, protective gloves		Dust mask

Tool Type	Description	Tool Type	Description
	goggle		Safety shoes

## 4.2 Equipment Handling

### CAUTION

- During transportation, handling, Installation, and other operations, it must comply with the laws, regulations, and relevant standards of the country or region where it is located.
- Before Installation, it is necessary to move Equipment Handling to Installation. To prevent personal injury or equipment damage during the transportation process, please NOTICE the following matters:
  1. Please equip the corresponding personnel according to the Weight to prevent the equipment from exceeding the Weight range that can be manually handled, thereby avoiding injury to personnel.
  2. Please wear safety gloves to avoid injury.
  3. Please ensure the equipment remains balanced during transportation to avoid falling.
  4. Battery system can be transported by hoisting to the Installation location.
  5. When lifting and moving equipment using a hoisting method, please use flexible slings or straps. The load-bearing capacity of a single strap must meet the following requirements:
    - GW5.1-BAT-D-G20, GW5.1-BAT-D-G21, GW6.0-BAT-D-G20  $\geq$  185KG
    - GW8.3-BAT-D-G20, GW8.3-BAT-D-G21, GW9.0-BAT-D-G20  $\geq$  240KG

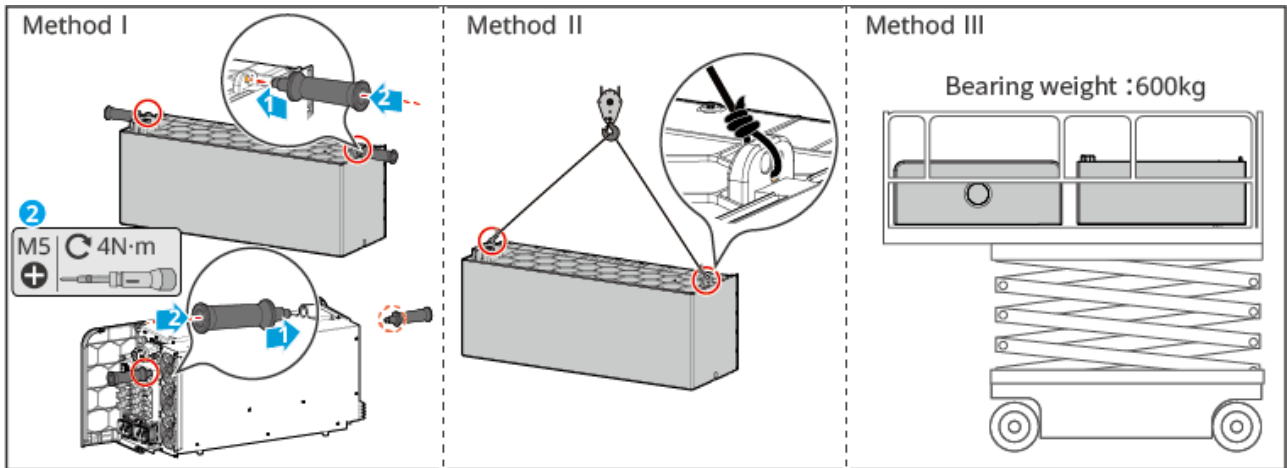

ESA20INT0013

## 4.3 Installing the Device

### ⚠ CAUTION

- When drilling, ensure the drilling position avoids water pipes, cables, etc., inside the wall to prevent danger.
- When drilling, please wear safety goggles and a dust mask to avoid inhaling dust into the respiratory tract or getting it into the eyes.
- The inverter is installed above the battery; do not install the battery above the inverter.
- When installing the battery system, ensure it is level and secure. When placing the battery base, battery, and inverter, confirm that the holes on the upper and lower layers are aligned; the anti-tipping bracket should be vertical and tightly attached to the ground, wall, or battery system surface.
- When using an impact drill to drill holes, use cardboard or other coverings to shield the battery system to prevent foreign objects from entering the equipment and causing damage.
- When wall-mounting, to ensure the safety of your life and property, be sure to assess the wall's load-bearing capacity.

## NOTICE

- The battery must be installed on the base, which can be floor-mounted or installed on a bracket.
- For floor installation, a maximum of 4 battery units can be stacked when away from the wall, and a maximum of 6 when against the wall.
- The maximum stacking quantity for bracket installation is described as follows:
  - Same energy stacking:
    - GW5.1-BAT-D-G20, GW5.1-BAT-D-G21: up to 3 units.
    - GW8.3-BAT-D-G20, GW8.3-BAT-D-G21: up to 2 units.
    - GW6.0-BAT-D-G20: up to 3 units.
    - GW9.0-BAT-D-G20: up to 2 units.
  - Mixed energy stacking:
    - GW5.1-BAT-D-G20, GW5.1-BAT-D-G21 mixed with GW6.0-BAT-D-G20, the system supports up to 3 units per group
    - GW8.3-BAT-D-G20, GW8.3-BAT-D-G21, GW9.0-BAT-D-G20 and models mixed with them, the system supports up to 2 units per group.
- When installing against the wall, the base, bracket, and top battery must be secured to the wall with anti-tip brackets.
- When marking drilling positions for bracket installation, have one person hold the base steady while another uses a marker pen to mark the drilling positions.
- When installing the battery and inverter, remove the protective cover on the blind plug connector before stacking.

### Wall-mounted Installation

**Step 1:** Install the base onto the wall bracket.

**Step 2:** Place the wall bracket flush against the wall. Ensure the bracket is positioned securely and observe the level bubble in the center of the base.

**Step 3:** After adjusting the position and level of the bracket, use a marker to mark the drilling points. After marking, remove the bracket. (A: PACK fixing holes; B: Bracket fixing holes.)

**Step 4:** Drill holes and install expansion bolts.

1. Use a hammer drill to create the holes.
2. Clean the holes.
3. Use a rubber mallet to install the expansion bolts into the holes.

4. Use a hex key to tighten the nuts clockwise to expand the bolts.
5. Rotate the nuts counterclockwise to remove them.
6. Use a torque screwdriver to secure the anti-tip bracket to the wall.

**Step 5:** Use a hex key to fix the wall bracket to the wall.

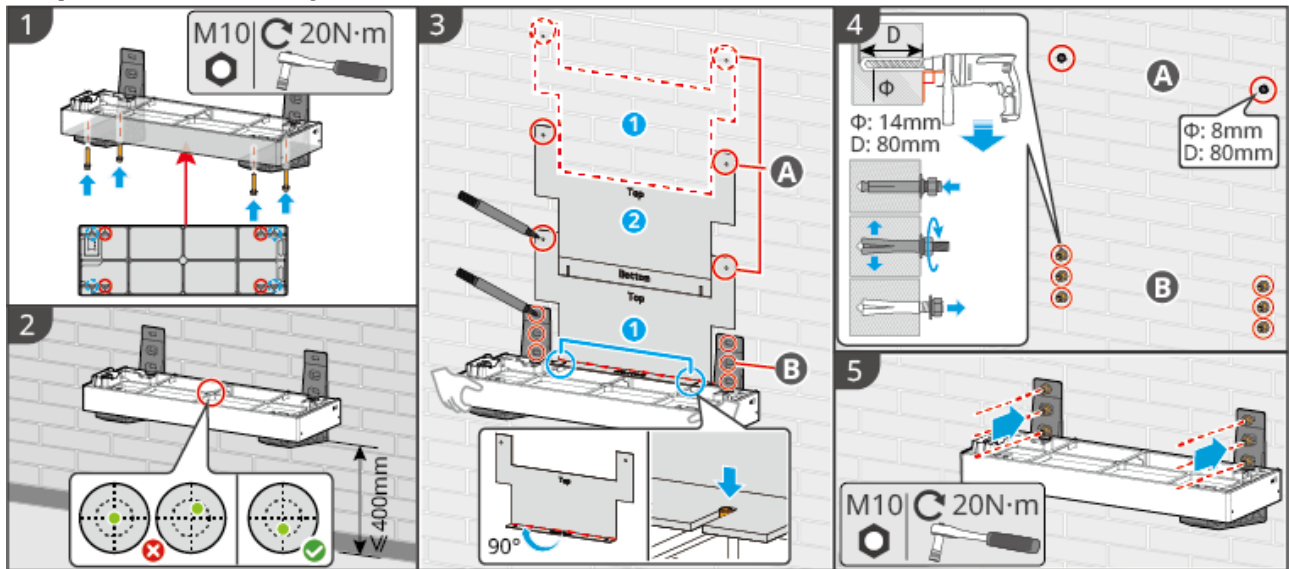

ESA20INT0003

## Floor Installation

### Wall-proximity Installation

**Step 1:** Install the adjustable feet onto the bottom of the base, and secure the anti-tip bracket to the base.

**Step 2:** Place the base 50-60mm away from the wall, keeping it parallel to the wall. Observe the level bubble in the center of the base. If the bubble is not centered, use the adjustable feet to level the base.

**Step 3:** After adjusting the position and level of the base, use a drilling template to mark the drilling points. After marking, remove the base. (A: PACK fixing holes; B: Bracket fixing holes.)

**Step 4:** Use a hammer drill to create the holes and clean them.

**Step 5:** Use a Phillips screwdriver to secure the anti-tip bracket to the wall.

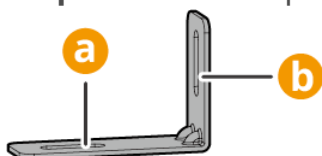

a: Surface for fixing to the base; b: Surface for fixing to the wall.

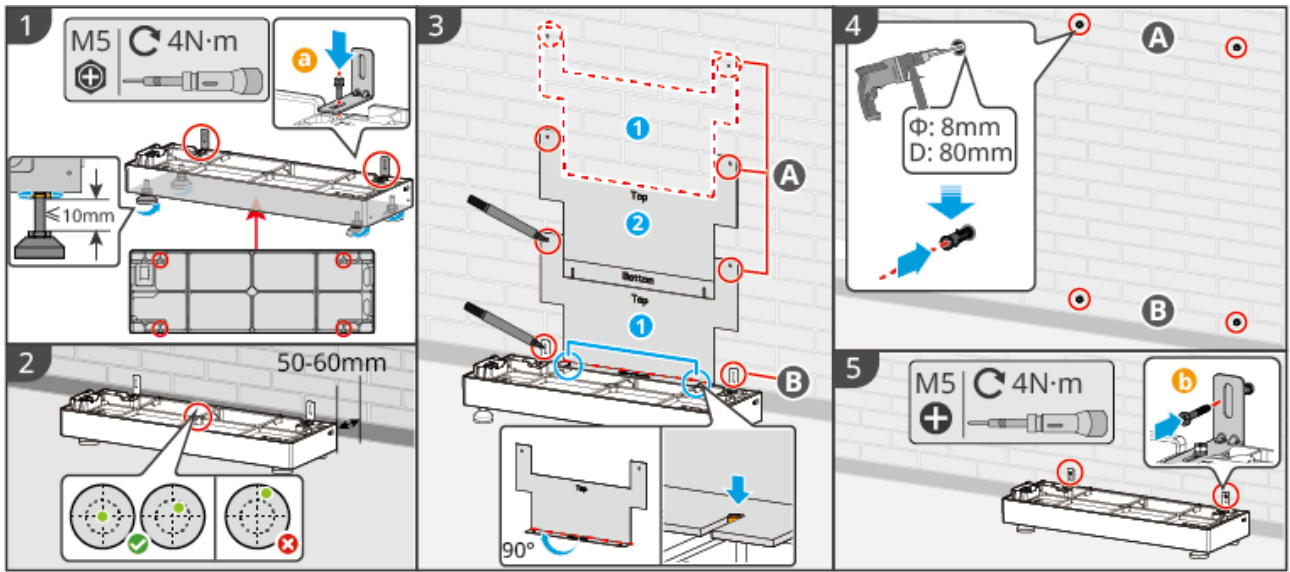

ESA20INT0004

### Off-Wall Installation

**Step 1:** Install the adjustable feet onto the bottom of the base. Observe the level bubble in the center of the base. If the bubble is not centered, use the adjustable feet to level the base.

**Step 2:** After adjusting the position and level of the base, secure the Floor-Mounted Anti-Sway Bracket to the base. Choose a suitable location to mark the drilling points. After marking, remove the base.

**Step 3:** Drill holes and install expansion bolts.

1. Use a hammer drill to create the holes.
2. Clean the holes.
3. Use a rubber mallet to install the expansion bolts into the holes.
4. Use a hex key to tighten the nuts clockwise to expand the bolts.
5. Rotate the nuts counterclockwise to remove them.
6. Use a torque screwdriver to secure the anti-wall-distance bracket to the floor.

**Step 4:** Use a hex key to secure the base to the floor.

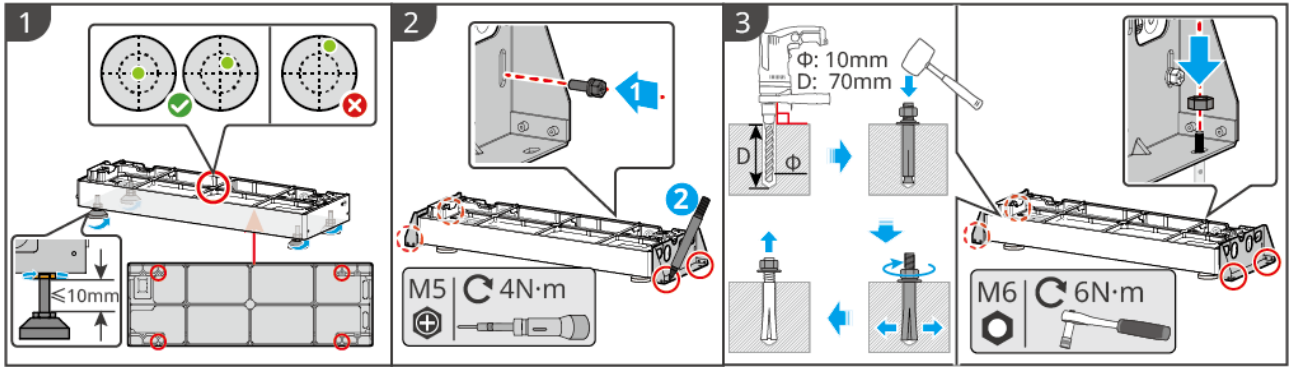

ESA20INT0015

## Installing the Battery and Inverter

### NOTICE

When wall-mounted, the topmost battery must be secured to the wall using an anti-tipping bracket.

**Step 1:** Remove the protective covers from the blind-mate connectors on the bottom of the inverter or battery.

**Step 2:** Install the handles (optional) and stack the battery onto the base.

If installing more than 3 batteries, use lifting equipment.

**Step 3:** Tighten the screws securing the battery to the base or between batteries.

If installing multiple batteries, repeat **Step 1** and **Step 2** to complete the installation of all batteries. The number of stacked batteries must comply with the "[2.2.1.System Overall Configuration Description\(Page 39\)](#)".

**Step 4:** (Optional) Secure the topmost battery to the wall using an anti-tip bracket.

**Step 5:** Install the inverter or battery decorative cover.

- Integrated Installation: Lift the inverter, align it, and stack it on top of the battery. Tighten the screws between the inverter and the battery. If the system is an integrated configuration, the installation is now complete.
- Split-type Expansion: Repeat the battery installation steps. After completing the electrical connections, place the battery decorative cover on top of the battery and tighten the side screws.

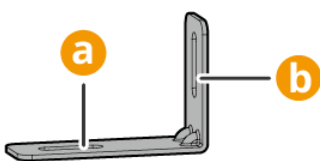

a: Surface for fixing to the PACK; b: Surface for fixing to the wall.

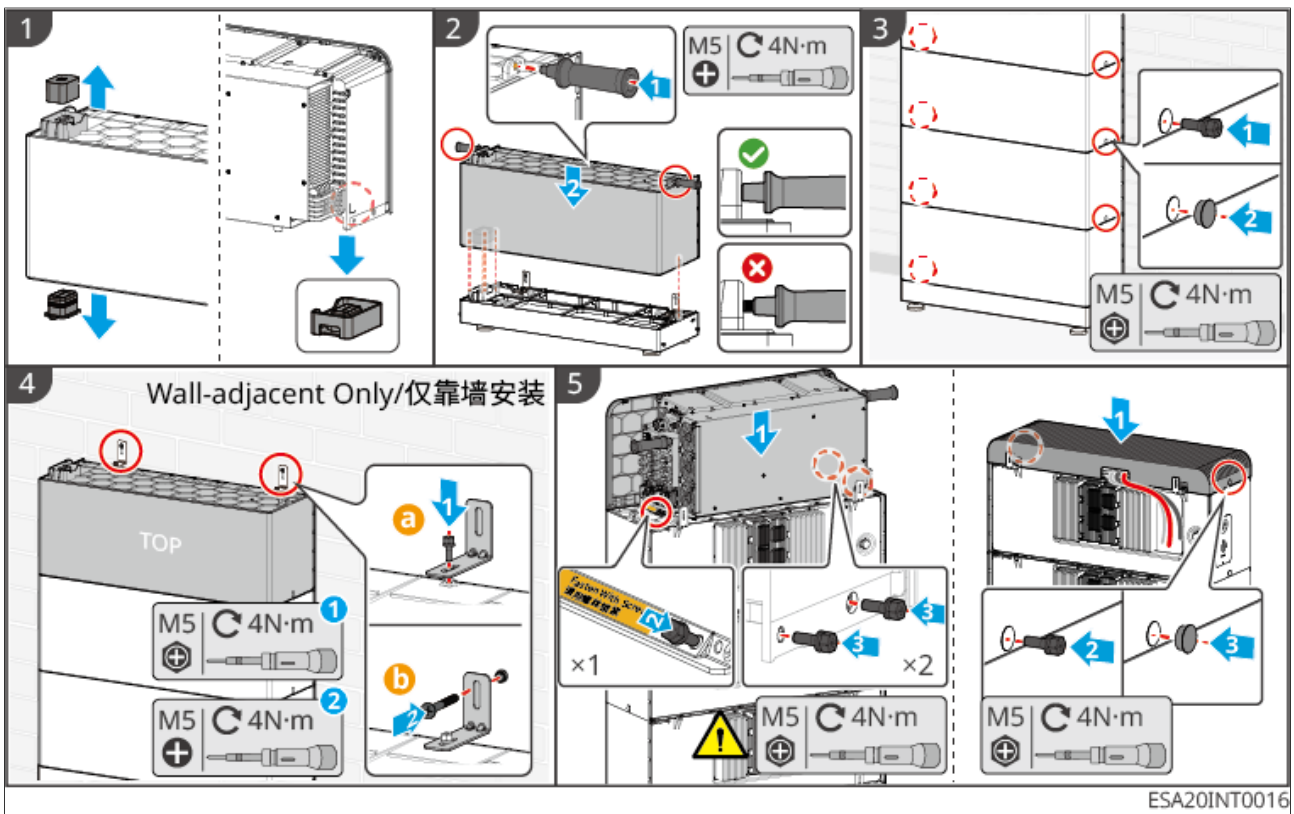

## 4.4 Installing the Smart Meter

### ⚠️ WARNING

In areas with lightning DANGER, if the meter cable length exceeds 10m and the cable is not routed with grounding Steel conduit, it is recommended to install external lightning protection devices.

GM330&GMK330

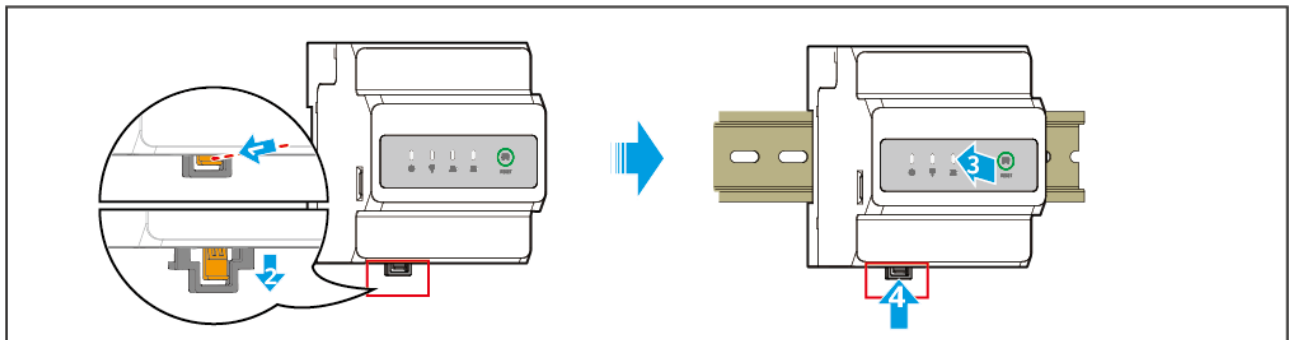

**Step 1:** Pull out the buckle at the bottom of the electricity meter.

**Step 2:**Place the meter on the positioning track and reinstall the buckle onto the meter.

## 5 System Wirings

### DANGER

- The installation, routing, and connection of cables must comply with local laws, regulations, and code requirements.
- All operations during electrical connection, as well as the specifications of cables and components used, must meet local legal and regulatory requirements.
- Before performing electrical connections, disconnect the DC switch and AC output switch of the equipment to ensure it is powered off. Live working is strictly prohibited, as it may lead to hazards such as electric shock.
- Cables of the same type should be bundled together and arranged separately from different types of cables. Intertwining or cross-routing is prohibited.
- If cables are subjected to excessive tension, poor connections may result. During wiring, leave a certain length of cable slack before connecting to the inverter terminals.
- When crimping terminals, ensure the conductor part of the cable makes full contact with the terminal. Do not crimp the cable insulation together with the terminal, as this may cause the equipment to malfunction, or lead to overheating and damage to the inverter terminal block due to unreliable connections during operation.
- The inverter is not tested to AS/NZS 4777.2:2020 for combinations and/or multiple phase inverter combinations so that combinations should not be used.
- Unused cable entry holes and ports (including communication ports) must be reliably sealed using the dedicated terminal blocks or plugs provided in the accessory kit. Failure to do so may result in the following risks:
  - Electric Shock Hazard: Open electrical ports may allow direct contact with live parts, leading to electric shock accidents.
  - Protection Failure: Open ports can allow dust, moisture, or foreign objects to enter, potentially causing short circuits, fires, or equipment failure.

## NOTICE

- When performing electrical connections, wear personal protective equipment such as safety shoes, protective gloves, and insulating gloves as required.
- Only qualified personnel are permitted to perform electrical connection operations.
- The cable colors shown in the graphics in this document are for reference only. Actual cable specifications must comply with local regulations.

## 5.1 System Wiring Electrical Block Diagram

### NOTICE

- According to the regulatory requirements of different regions, the wiring methods for the N and PE lines of the inverter GRID and BACK-UP ports are different. Please refer to local regulations for specifics.
- The inverter has a built-in meter and can be directly connected to the CT for use. The CT network cable shipped with the box is 10 meters. If a longer distance is required, it can be extended to 30 meters using shielded network cable of CAT5E or above.
- When the connection length between the CT and the inverter exceeds 30m, accuracy will decrease. If high precision is required, an external smart meter can be connected.
- The inverter GRID AC port has a built-in relay. When the inverter is in off-grid mode, the built-in GRID relay is in the open state; when the inverter is in grid-connected operation mode, the built-in GRID relay is in the closed state.
- After the inverter is powered on, the BACK-UP AC port is live. If maintenance is required on the BACK-UP Loads, please power off the inverter; otherwise, it may cause electric shock.
- In whole-house backup scenarios, if the total power of the connected loads exceeds 1.1 times the rated power of the inverter, after a grid power outage, the inverter will stop output due to overload protection. At this time, please turn off some non-essential loads to ensure that the total load power is less than 1.1 times the rated power of the inverter.

**N and PE wires are connected together in the distribution box.**

## NOTICE

- To maintain neutral integrity, the neutral wires on the grid side and the off-grid side must be connected together; otherwise, the off-grid function will not operate correctly.
- The diagram below illustrates the grid system for regions such as Australia and New Zealand:

### Whole house backup power

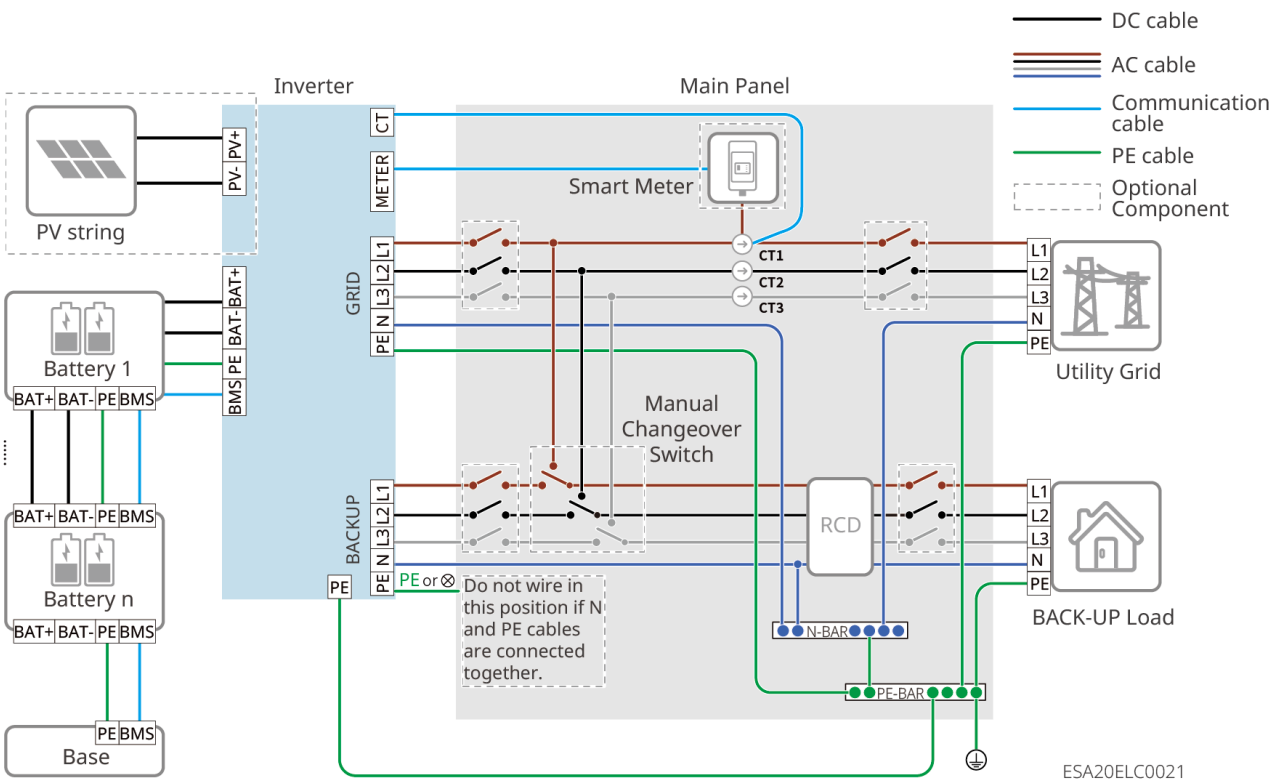

### Partial backup power

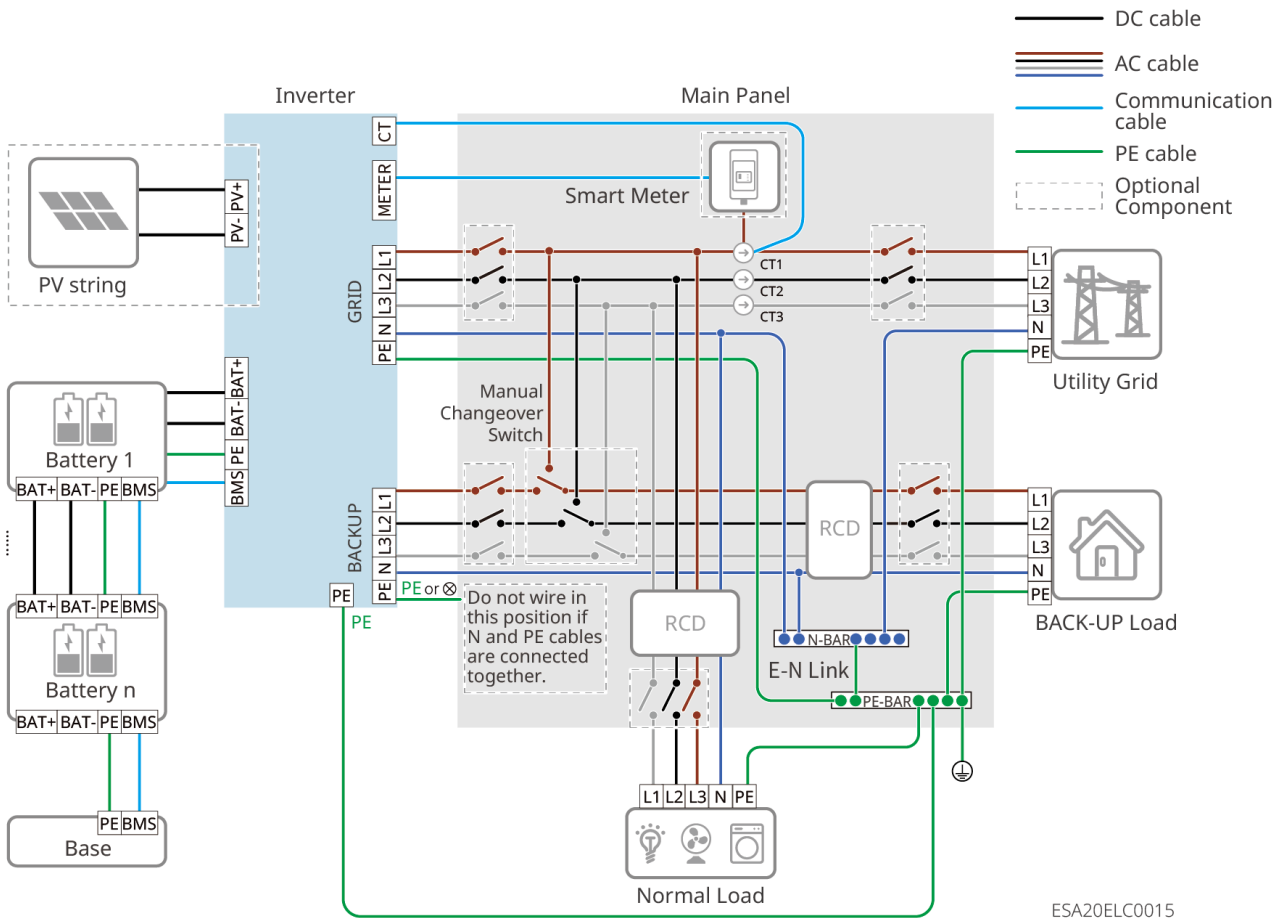

**N and PE wires are separately wired in the distribution box.**

### NOTICE

- Ensure the protective ground wire for the BACK-UP is correctly and securely connected; otherwise, the BACK-UP function may operate abnormally in the event of a grid fault.
- In a parallel system, do not install Residual Current Devices (RCDs) on the grid-connected branch of each inverter. RCDs should be installed uniformly at the grid aggregation point.
- The following wiring method applies to regions other than Australia, New Zealand, etc.:

Whole house backup power

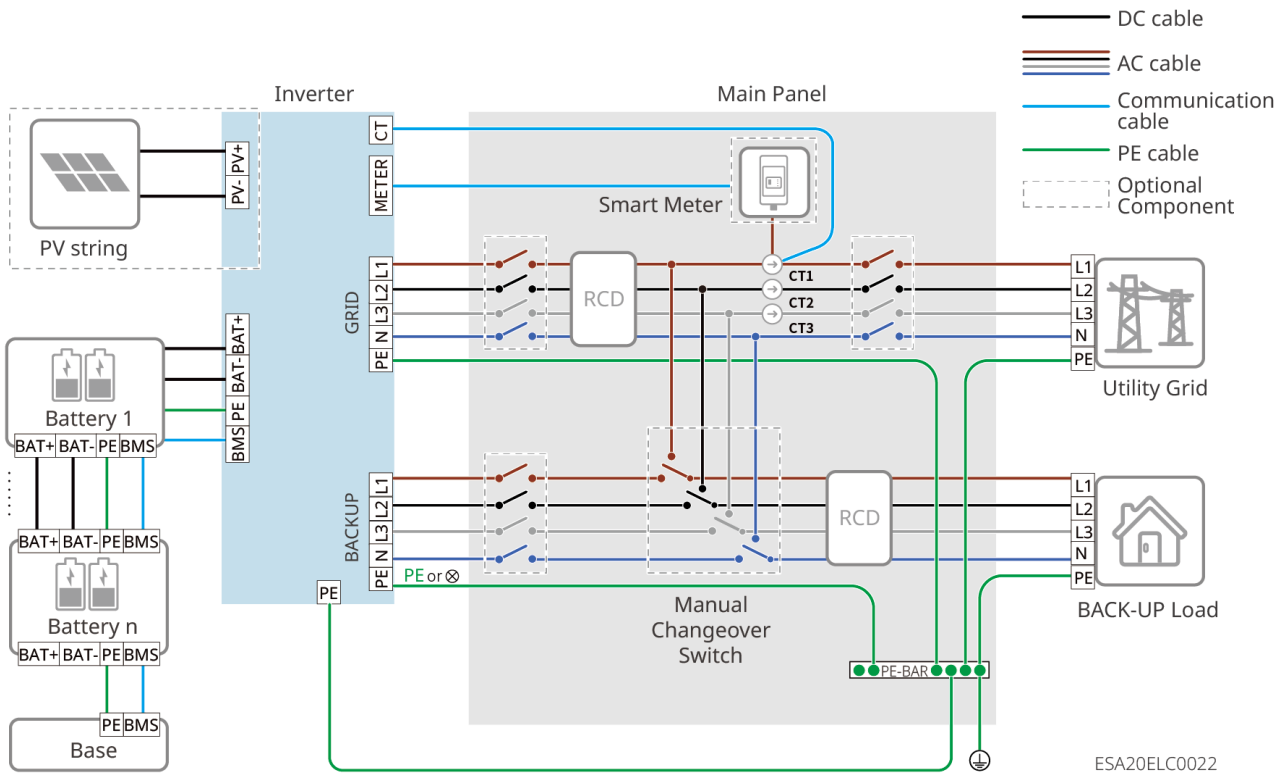

ESA20ELC0022

Partial backup power

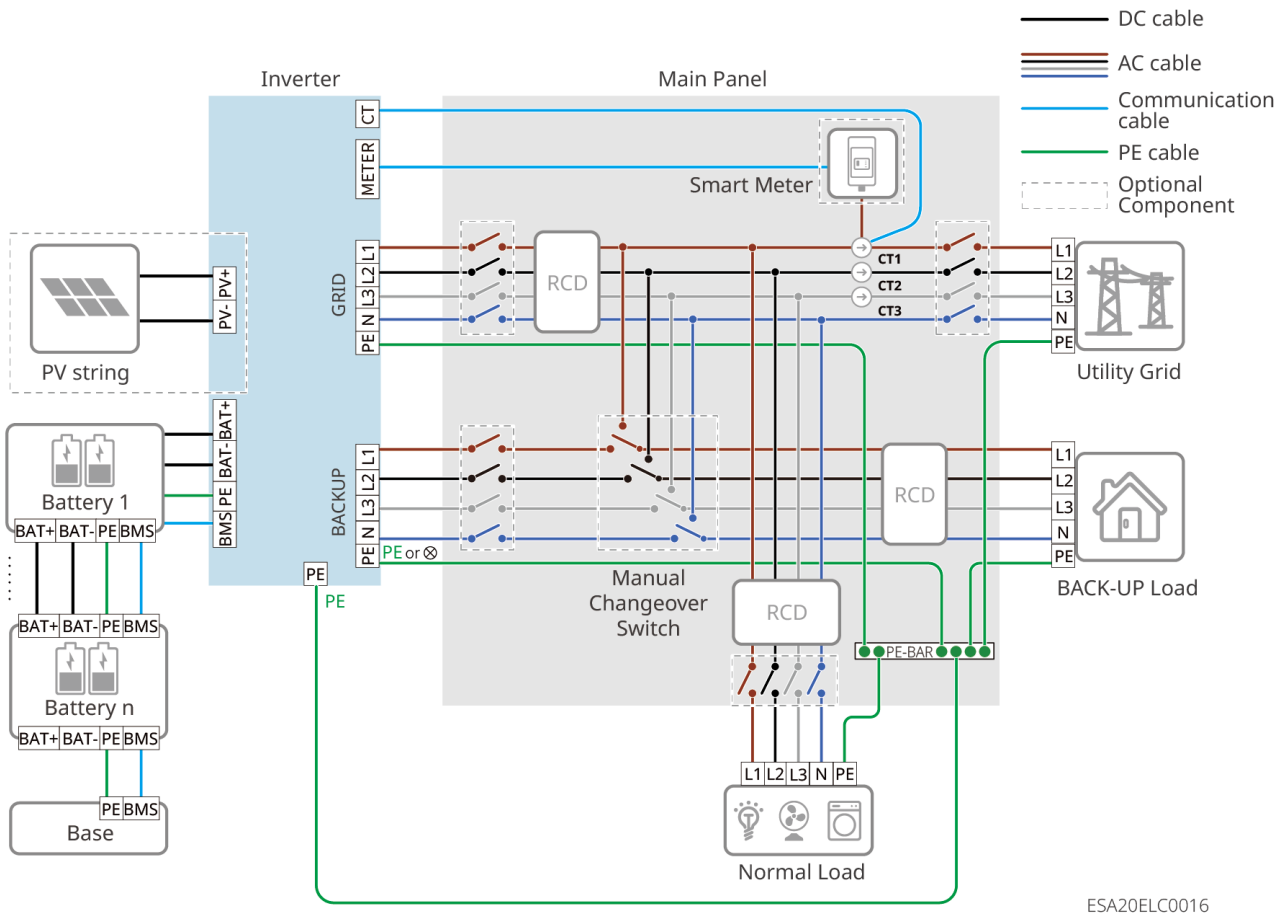

## 5.2 Detailed System Wiring Diagram

When all loads in the photovoltaic system cannot consume the electricity generated by the system, the surplus electricity is fed into the grid. At this time, it can be paired with a smart meter or CT to monitor the system's power generation and control the amount of electricity fed into the grid.

- Connecting a smart meter enables output power limiting and load monitoring functions.
- After connecting the smart meter, please enable the 'Export power limit' function via the SEMS+ App.

The detailed system wiring diagram only shows wiring examples for some model devices. Please refer to the corresponding wiring guidance chapter based on the actual devices used for wiring.

 **WARNING**

The common contact of the manual transfer switch must be connected to the BACK-UP load side of the Inverter, and must not be connected to the GRID utility side. If connected to the GRID utility side, the Inverter's off-grid mode and bypass mode will run simultaneously. When a utility power outage occurs, the distribution cabinet connected to the Inverter's GRID port will still have high voltage, posing a risk of electric shock.

Australia Region

**NOTICE**

In Australia, a 3-pole manual transfer switch is included in the product shipping box. If required for use, please wire it according to the 3-pole manual transfer switch wiring method shown in the wiring diagram below.

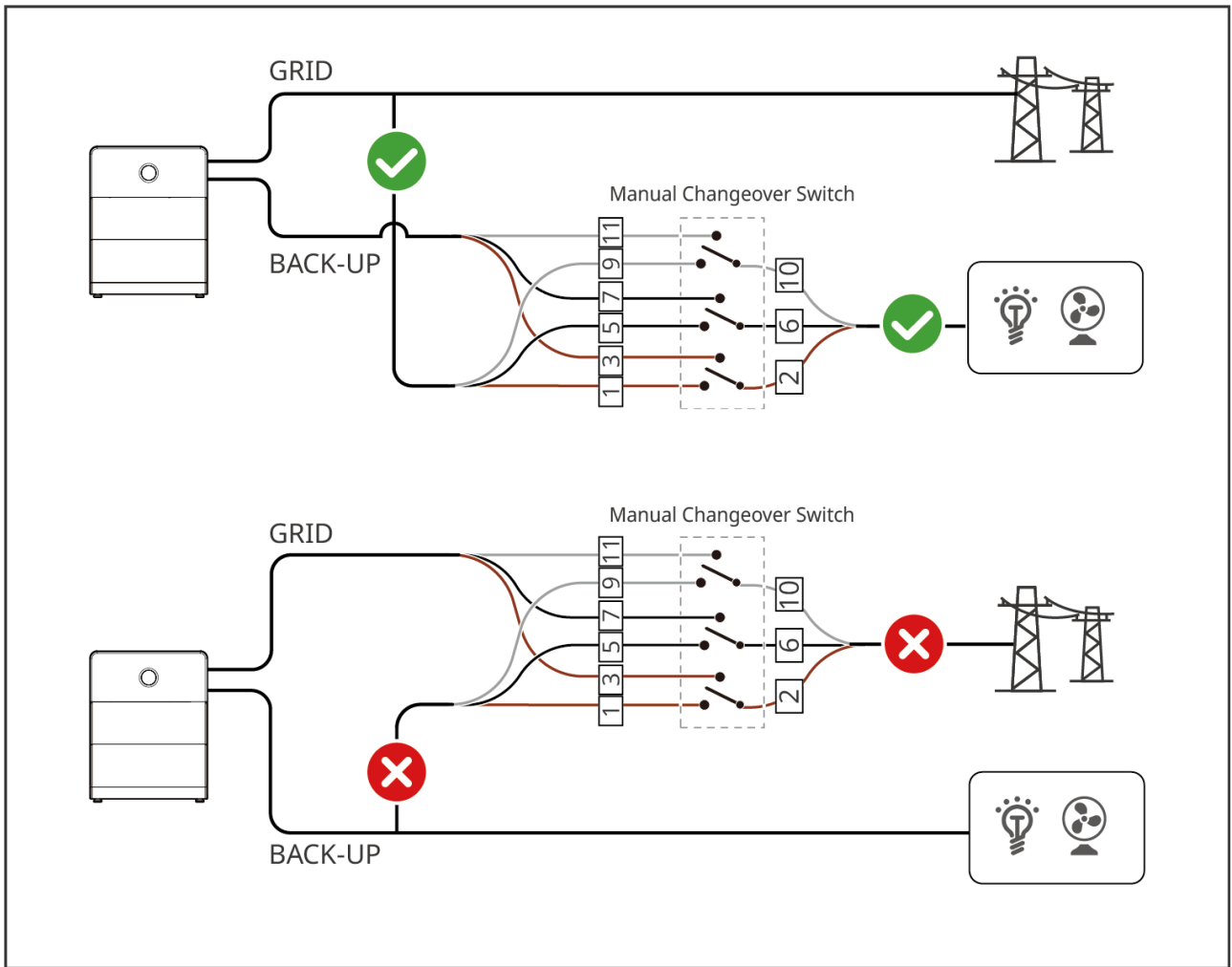

ESA20ELC0019

Europe Region

### NOTICE

In the European region, if a manual transfer switch is required, please purchase a 4-pole manual transfer switch through a distributor or procure it yourself. After obtaining this switch, please wire it according to the 4-pole manual transfer switch wiring method shown in the following wiring diagram.

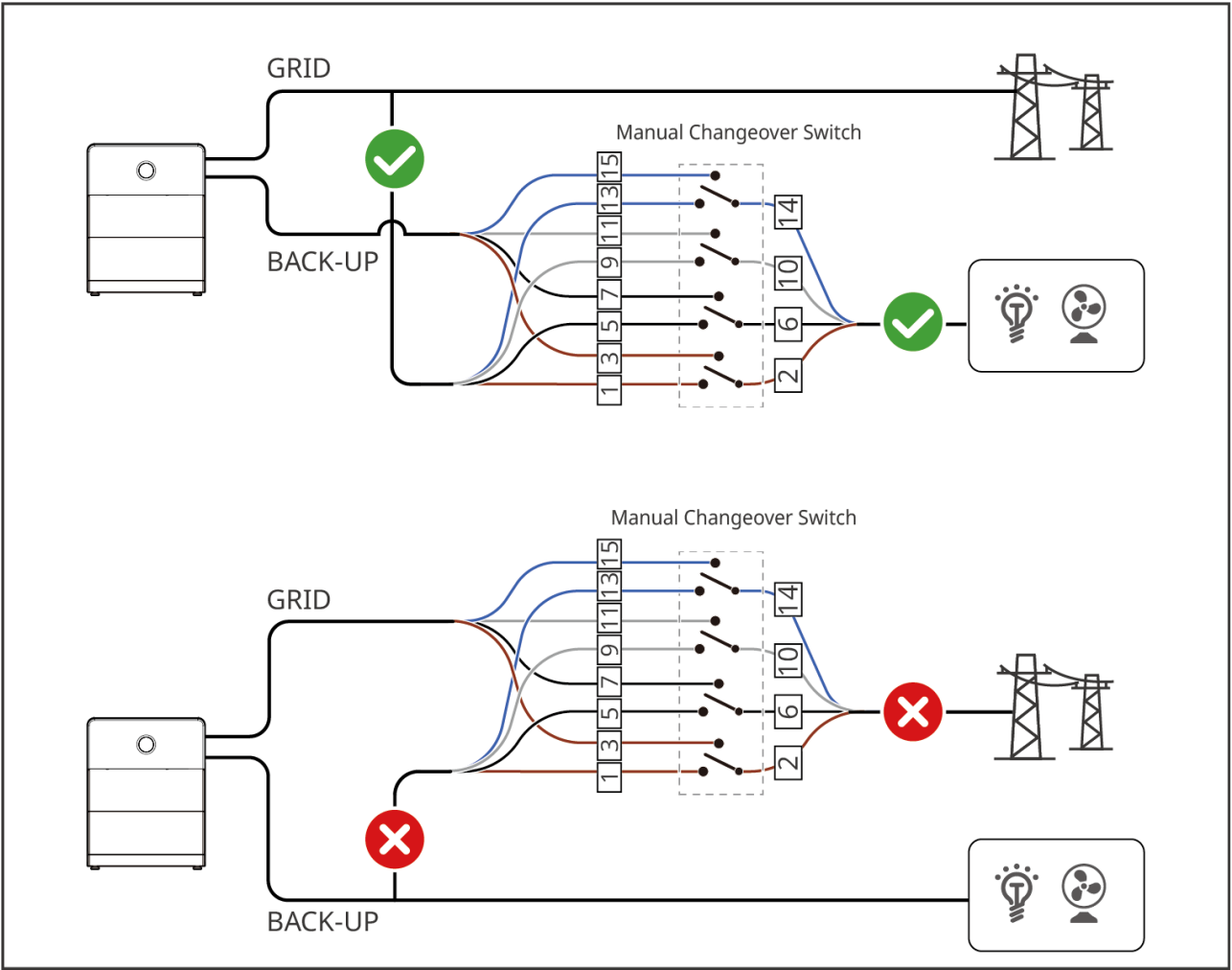

ESA20ELC0035

## NOTICE

- For microgrid and coupling scenarios, if grid-tied inverter power generation monitoring and load monitoring functions are required, a dual-meter networking setup must be used.
  - Meter 1 or the built-in meter is used to monitor the system's grid-connected power.
  - Meter 2 is used to monitor the grid-tied inverter's power generation.
  - By integrating data from Meter 1 and Meter 2, the monitoring platform can achieve real-time monitoring of the load's power consumption.
- If output power limitation is required for the grid-tied inverter, please connect separate devices such as a meter or CT.
- For microgrid and coupling scenarios with dual meters, the meter wiring method is the same.
- When not using the inverter's built-in meter, do not connect to the inverter's CT port.
- Parallel operation of energy storage inverters is not supported in microgrid scenarios.
- The manual transfer switch is only supported for use in single-unit scenarios. Please decide whether to install it based on the actual usage scenario; if using a self-provided ATS or STS switch, this switch must have an interlock function.

### Dual Meter Configuration Scenarios

Meter 1 (Grid Side)	Meter 2 (Grid-tied Inverter AC Side)
Built-in Meter	GMK330
Built-in Meter	GM330
GMK330	GMK330
GM330	GM330
GMK330	GM330
GM330	GMK330

## 5.2.1 Detailed System Wiring Diagram for Single Inverter

# General Scenario

## Scenario with Built-in Meter

The scenario with a built-in meter does not support connection to a generator.

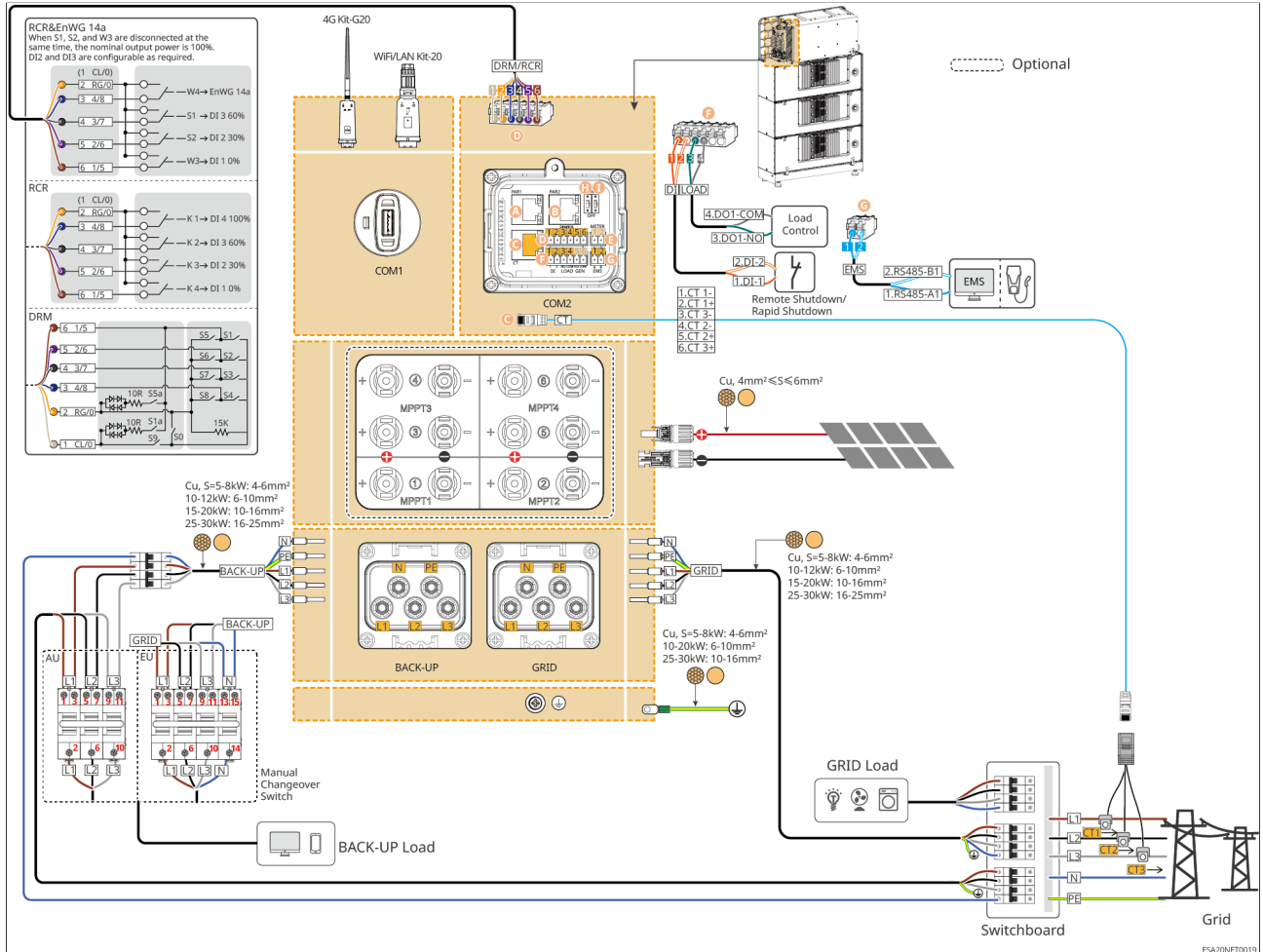
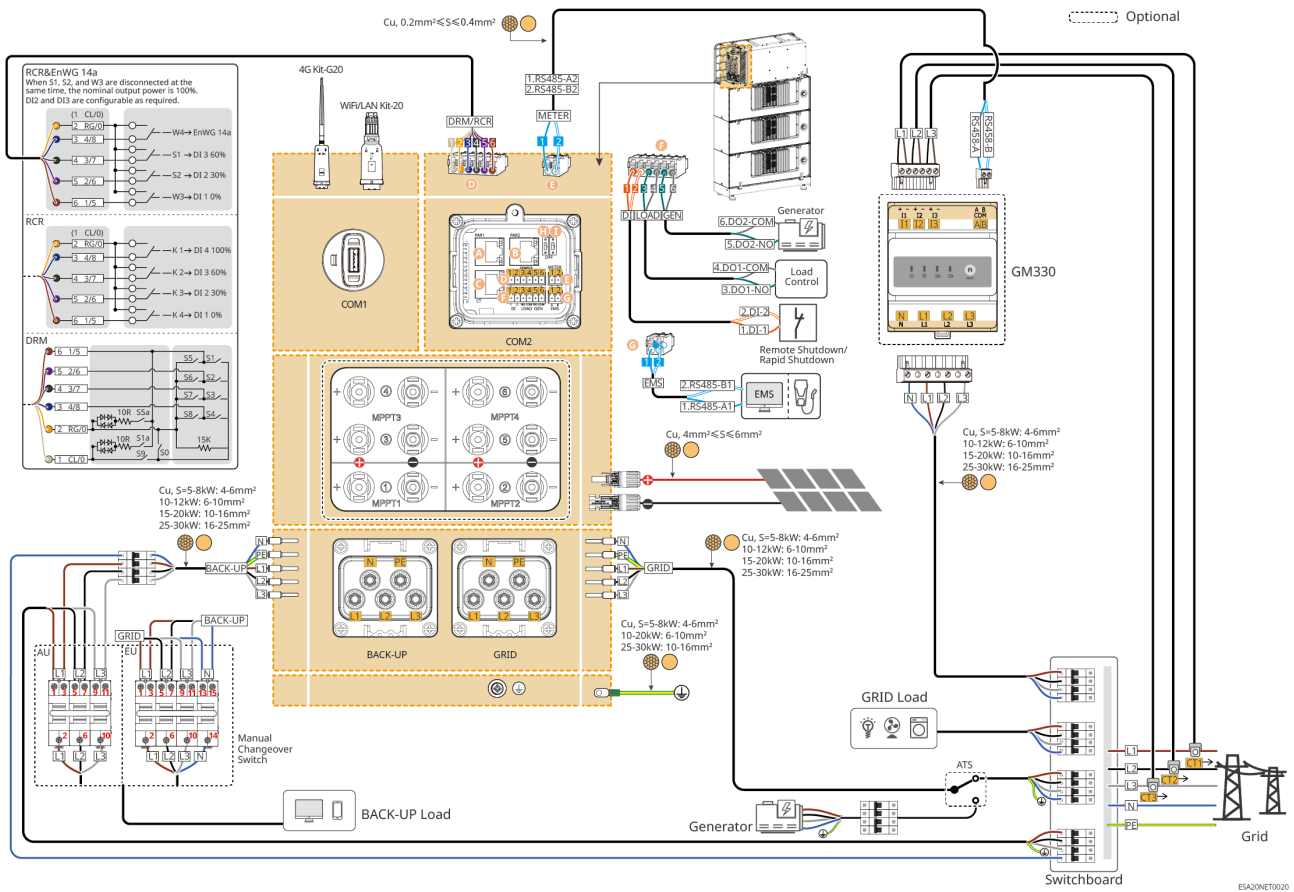
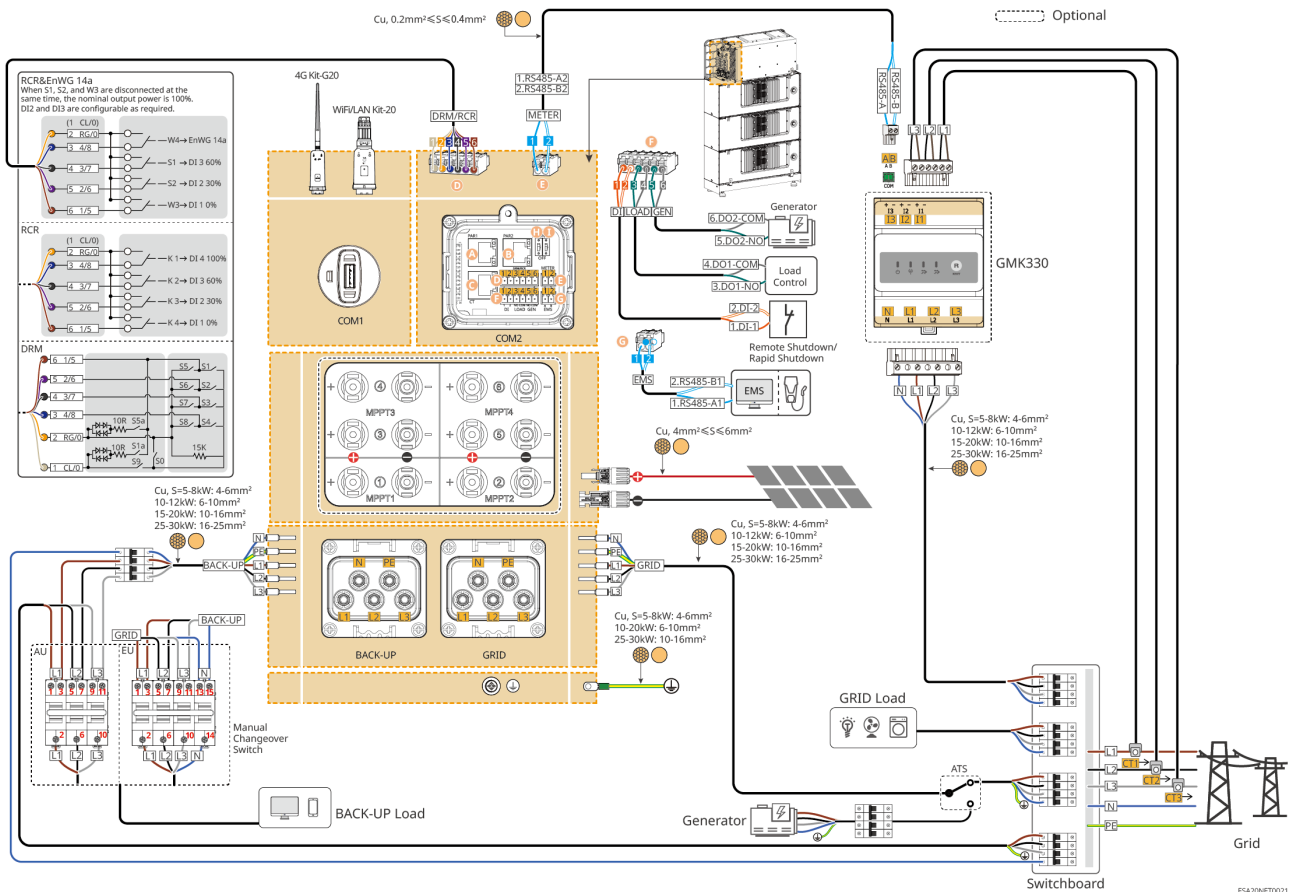

Figure11 Scenario with Built-in Meter

## Scenario with GM330 Meter



Scenario with GMK330 Meter



### Microgrid Scenario Networking Diagram

- The Microgrid Scenario does not support connection to a generator.
- The manual transfer switch is optional. Please decide whether to install it based on the actual usage scenario.

### Built-in Meter + GM330 Meter Networking Diagram

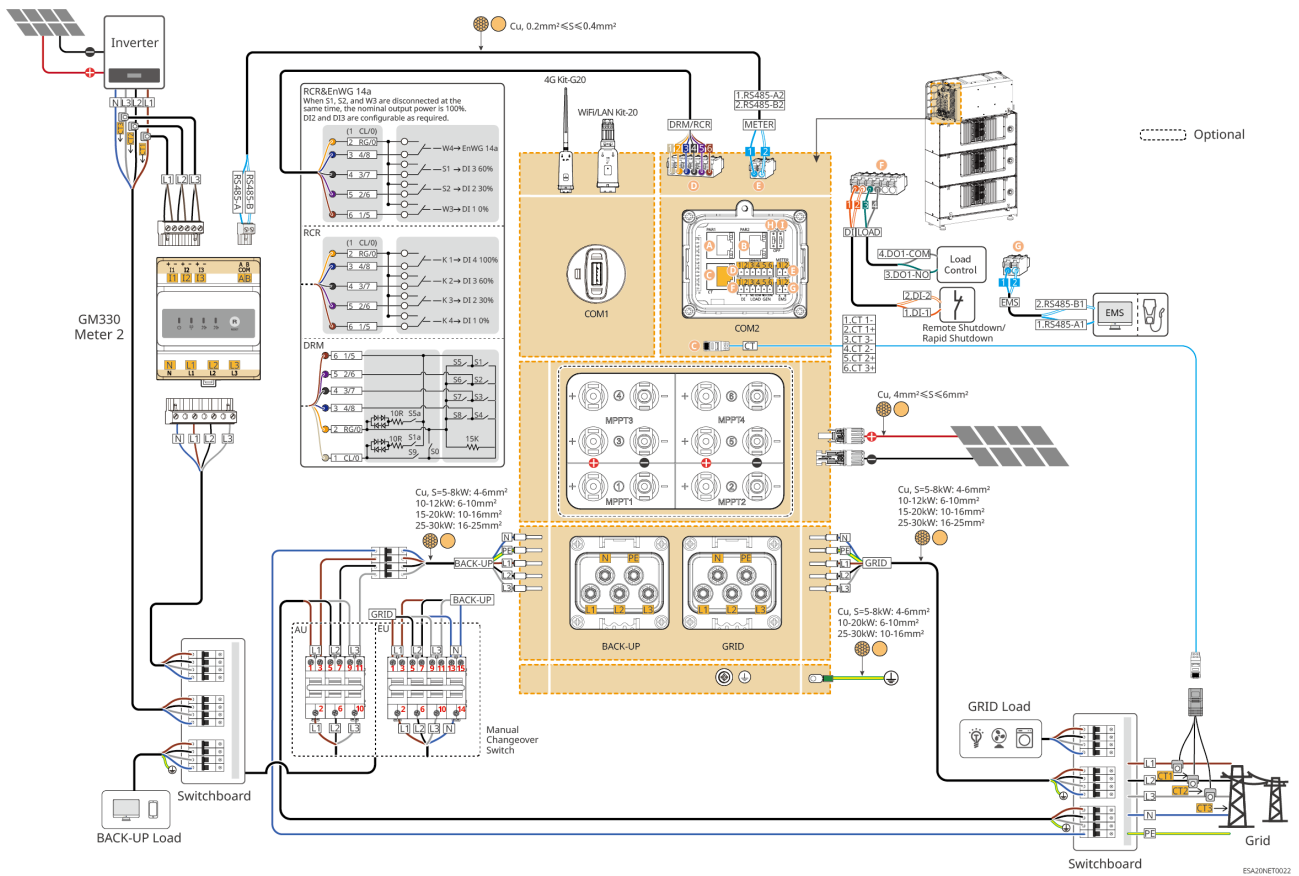

GMK330 + GMK330

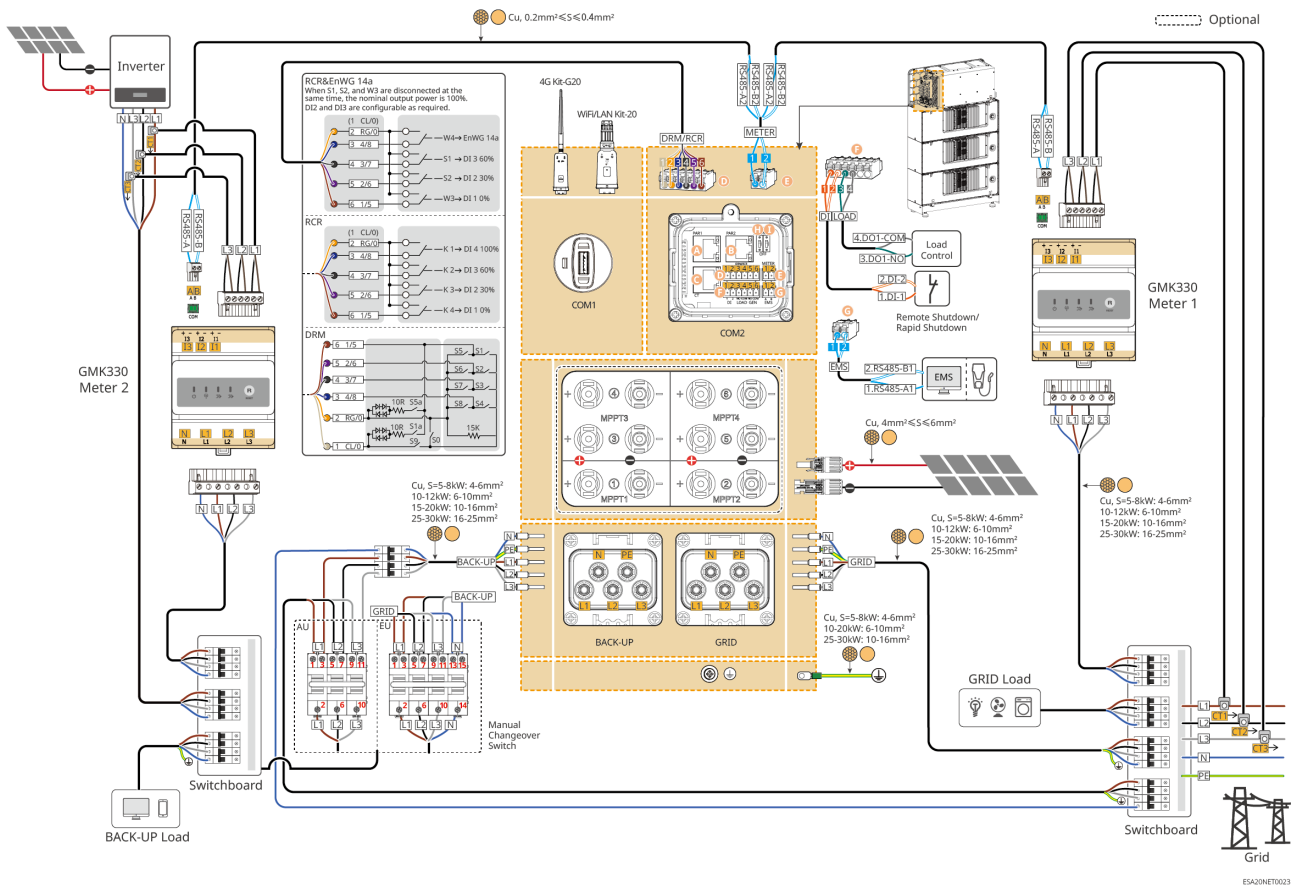

## Microgrid Scenario, Grid-Tied Inverter Grid Power Limiting Networking Diagram

In a Microgrid Scenario, if grid power limiting is required for the grid-tied inverter, please connect a meter or CT device separately.

GM330 + GMK330

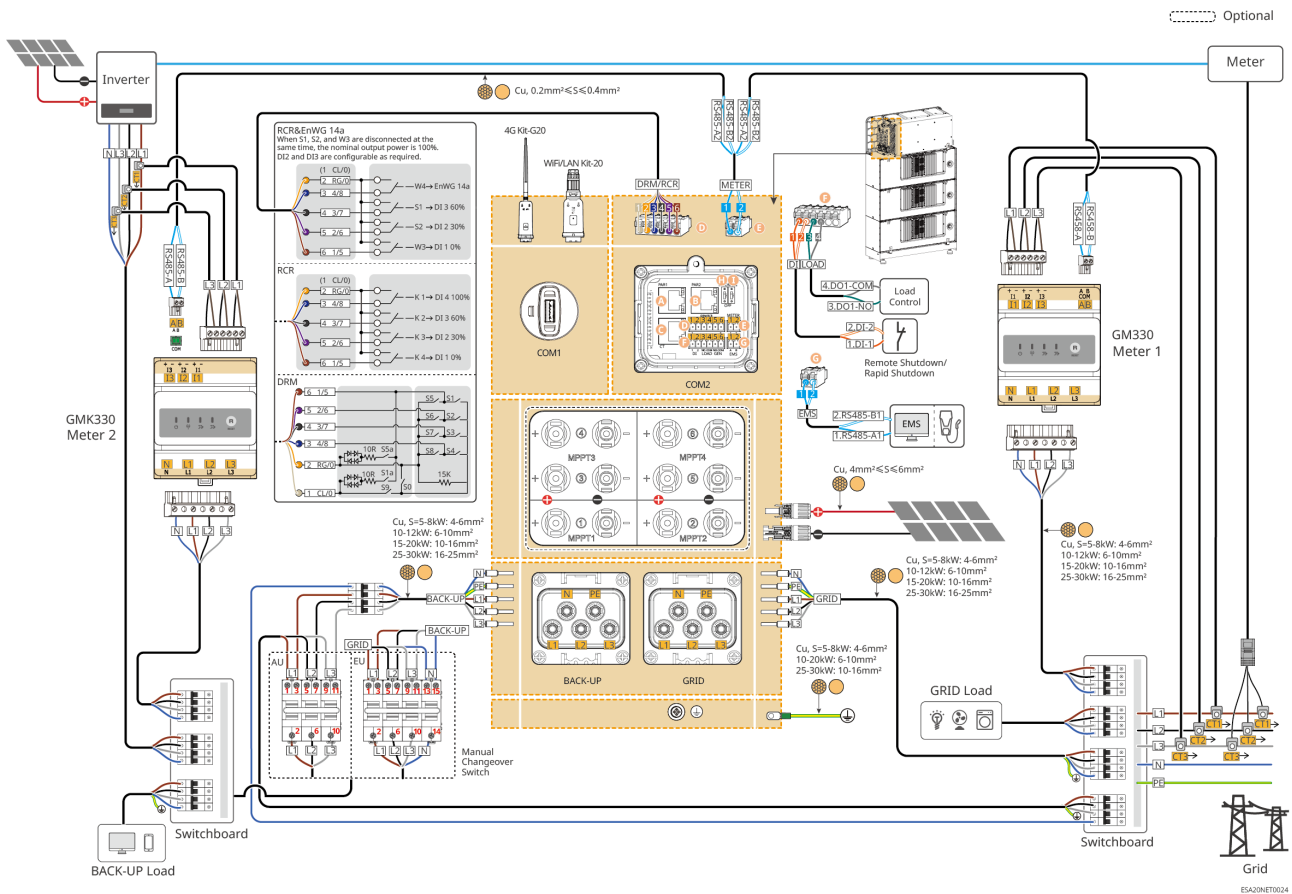

## Coupled Scenario Dual Meter Networking Diagram

- The manual transfer switch is optional. Please decide whether to install it based on the actual usage scenario.
- The scenario with a built-in meter does not support connection to a generator.

### Built-in Meter + GMK330

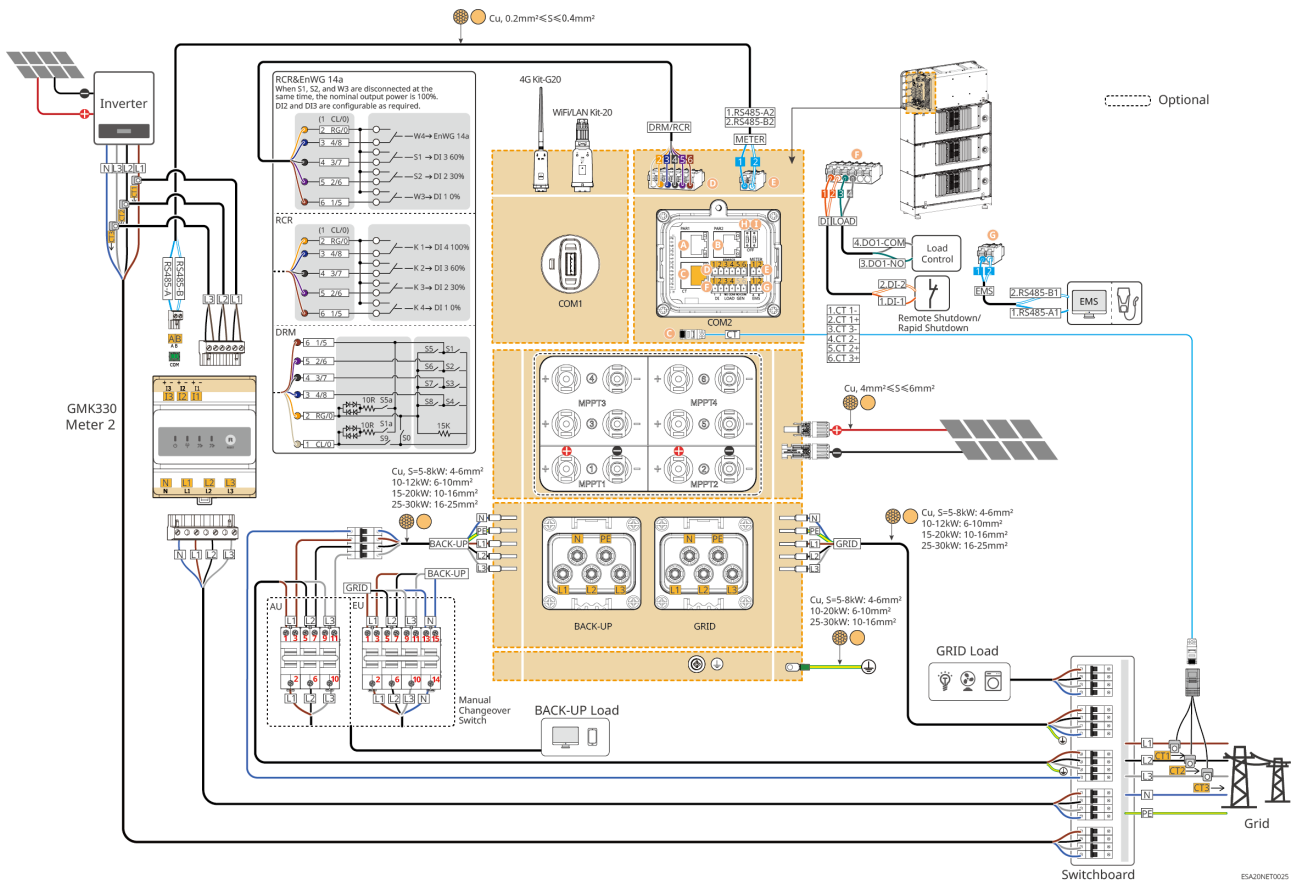

GM330 + GM330 Networking Diagram

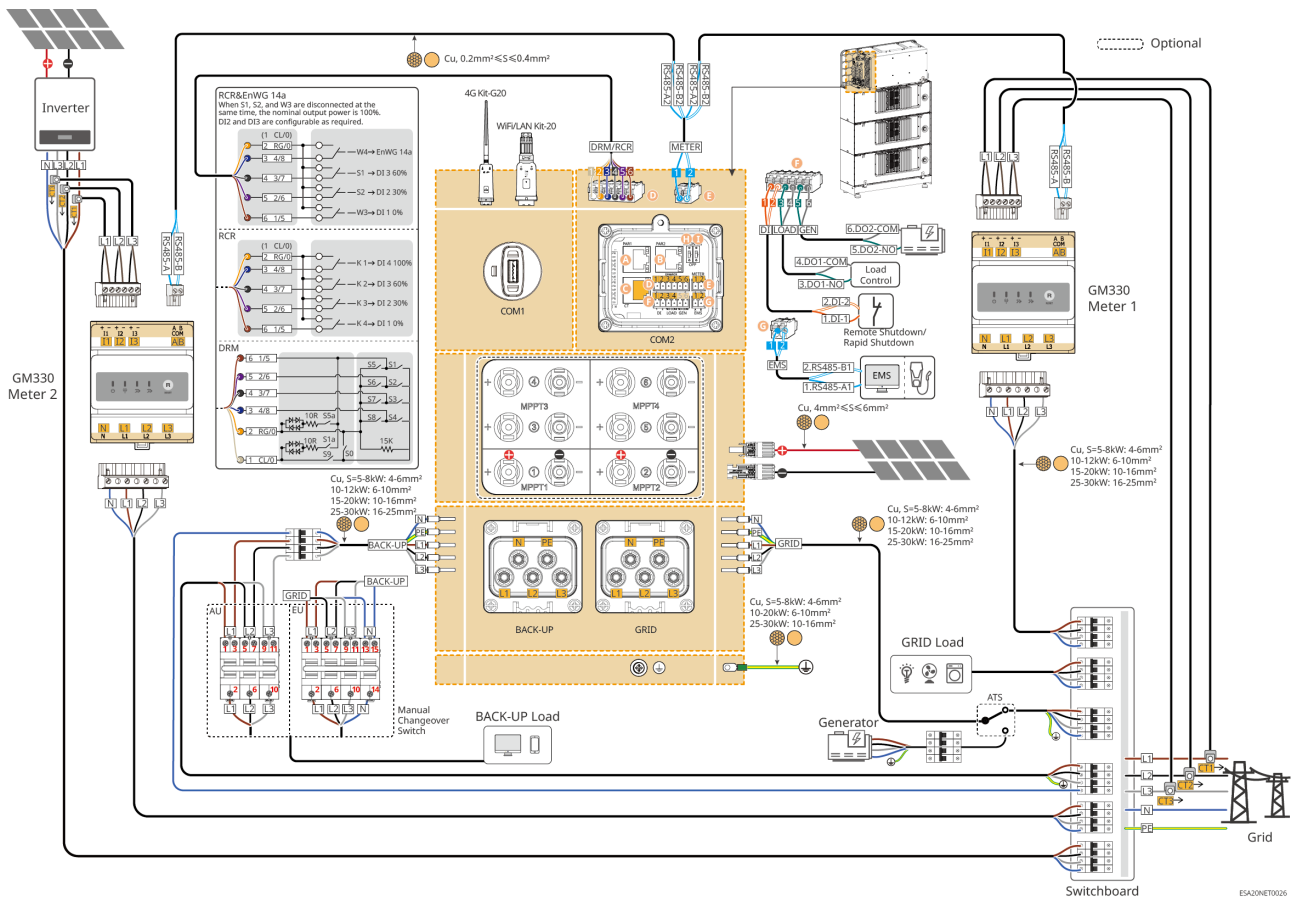

## Coupled Scenario, Grid-Tied Inverter Grid Power Limiting Networking Diagram

In a Coupled Scenario, if grid power limiting is required for the grid-tied inverter, please connect a meter or CT device separately.

GMK330 + GM330

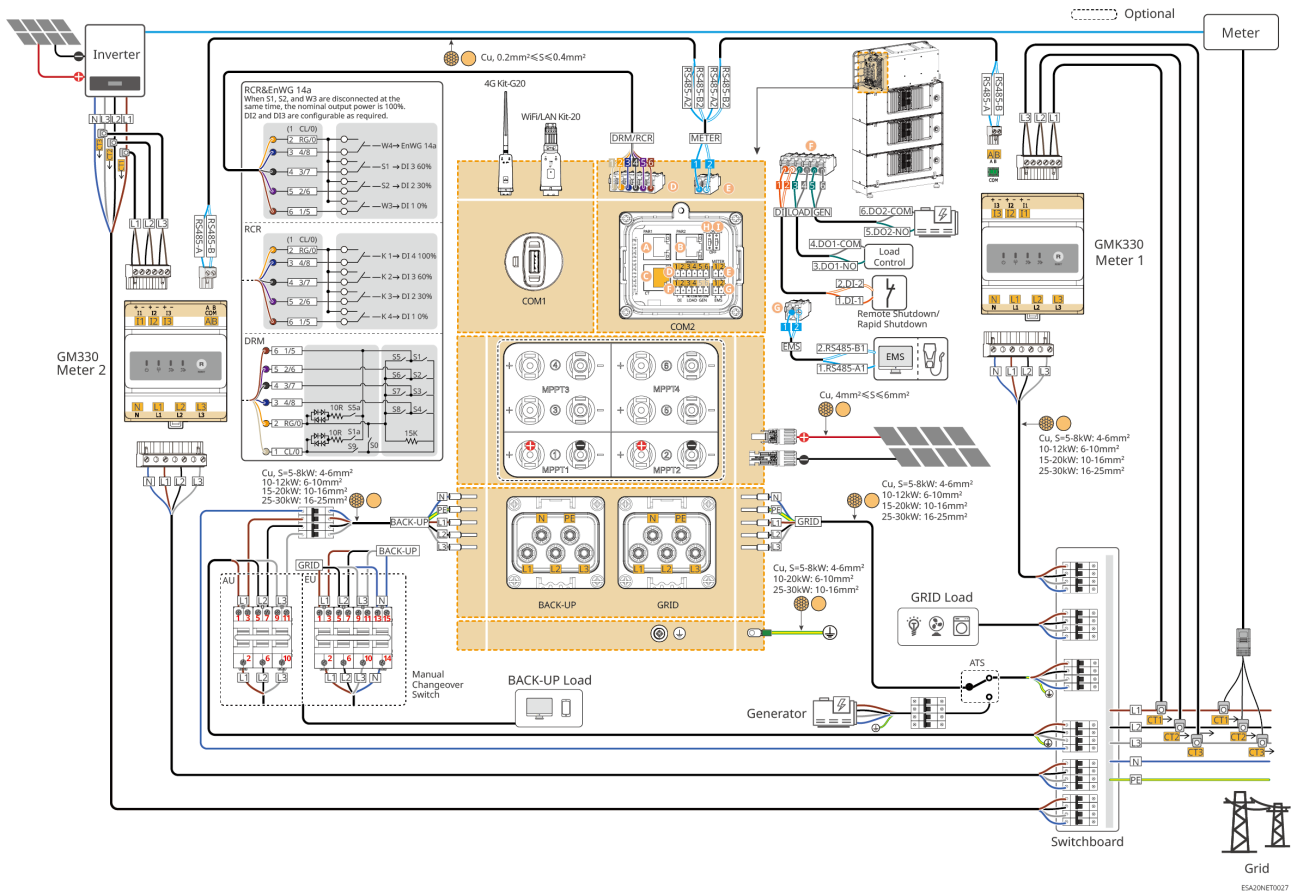

## 5.2.2 Detailed System Wiring Diagram for Parallel System

## NOTICE

- If the system requires connection of DRED devices, RCR devices, remote shutdown devices, NS Protection, SG Ready heat pumps, etc., please connect them to the master inverter.
- Remote shutdown function: Connect the communication cable to the master inverter. Rapid shutdown function: Connect the communication cable to each inverter individually. If both rapid shutdown and remote shutdown functions are required simultaneously, please contact the after-sales service center.
- In a parallel system, each inverter needs to be installed with a WiFi/LAN Kit-20.
- The built-in meter of the inverter supports system parallel networking. During parallel operation, the total system current must not exceed the rated primary current of the standard CT.
- The parallel system supports generator connection. If connecting a generator, please ensure:
  - The generator power must be greater than the total power of all loads on the BACKUP port.
  - The current capacity of the matching ATS can meet the total current requirement when all inverters output at rated power simultaneously.
- In a parallel system, if it is necessary to disconnect the circuit breaker for any port of an inverter, please simultaneously disconnect the circuit breakers for other ports of that inverter; otherwise, it may cause abnormal system operation.
- In a parallel system, set the DIP switches of the first and last inverters to the ON position, and set the DIP switches of other inverters to the OFF position.
- If the number of parallel inverters exceeds 2, or if the wire gauge or range of the standard CT does not meet the total current requirement of the on-site parallel system, please use the GM330 smart meter.
- The following diagrams focus on the wiring related to parallel connection. For wiring requirements of other ports, please refer to the single-unit system.

In a parallel system scenario, the inverter connected to the meter is the master inverter, and the others are slave inverters.

The master inverter needs to be set as the master via the App's 'Set RS485 Parallel System' function. Slave inverters also need to be set as slaves. For specific steps, please refer to the App User Manual.

### General Scenarios

With built-in meter scenario

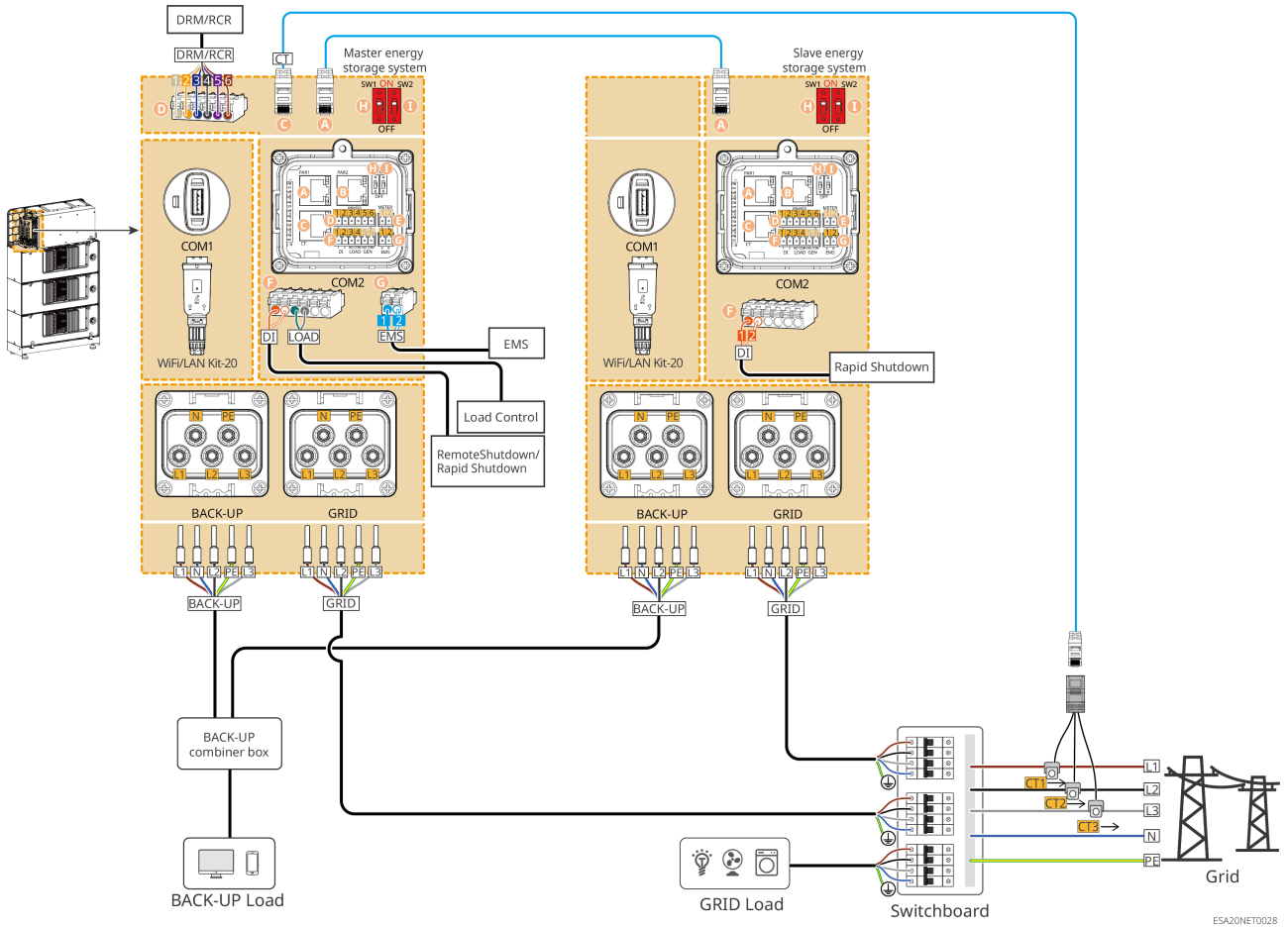

With GM330 scenario

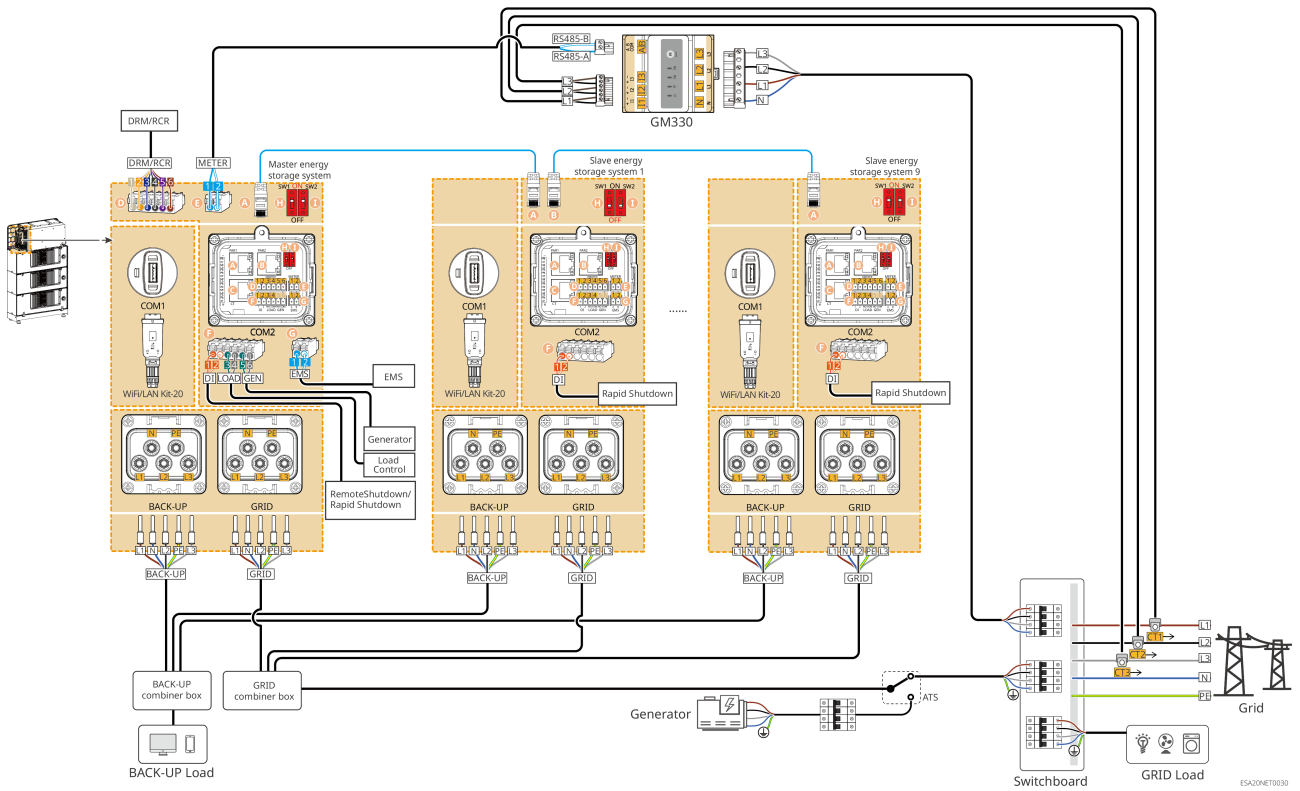

With GMK330 scenario

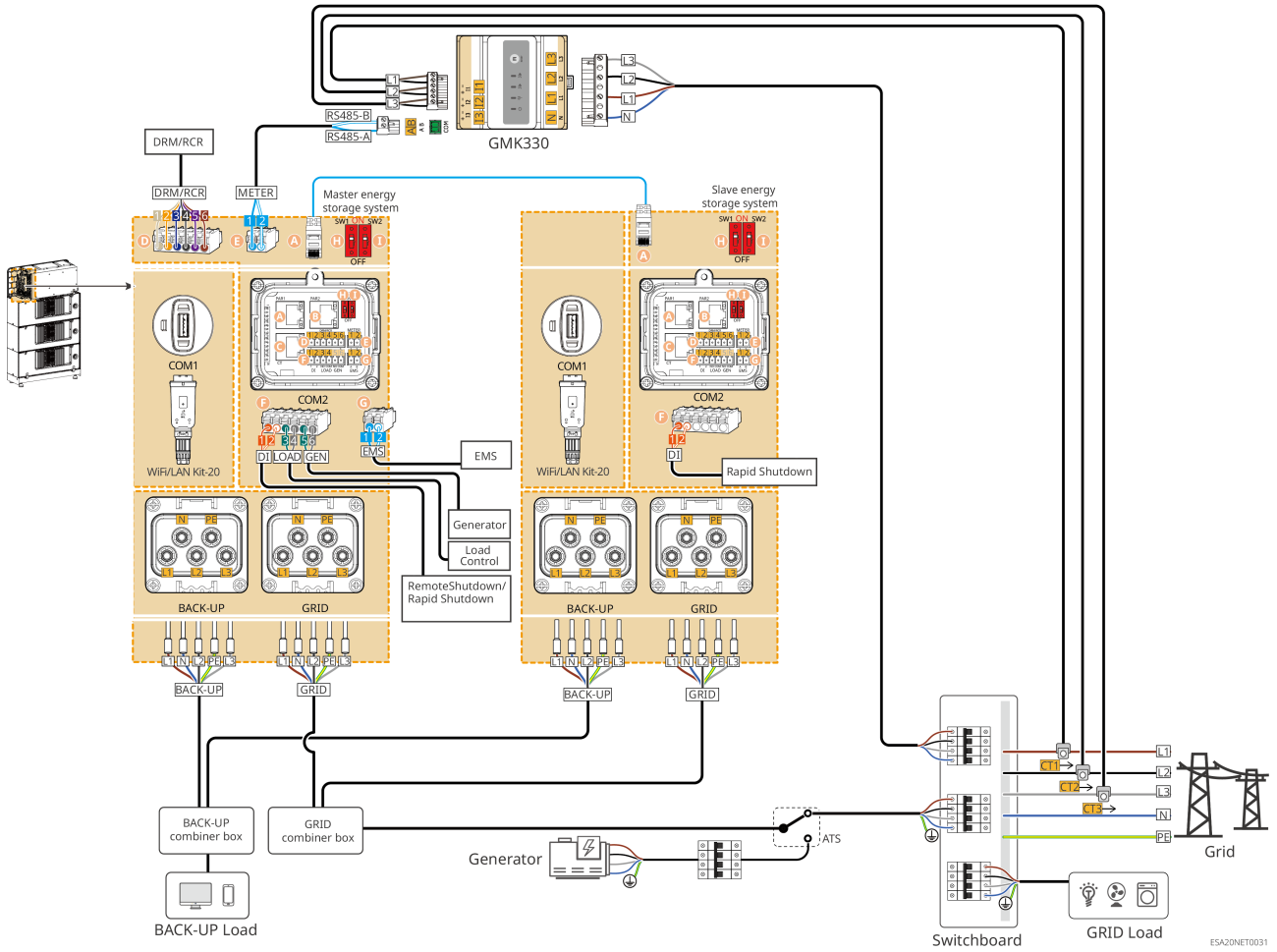

## Coupling Scenarios

GM330 + GM330 networking

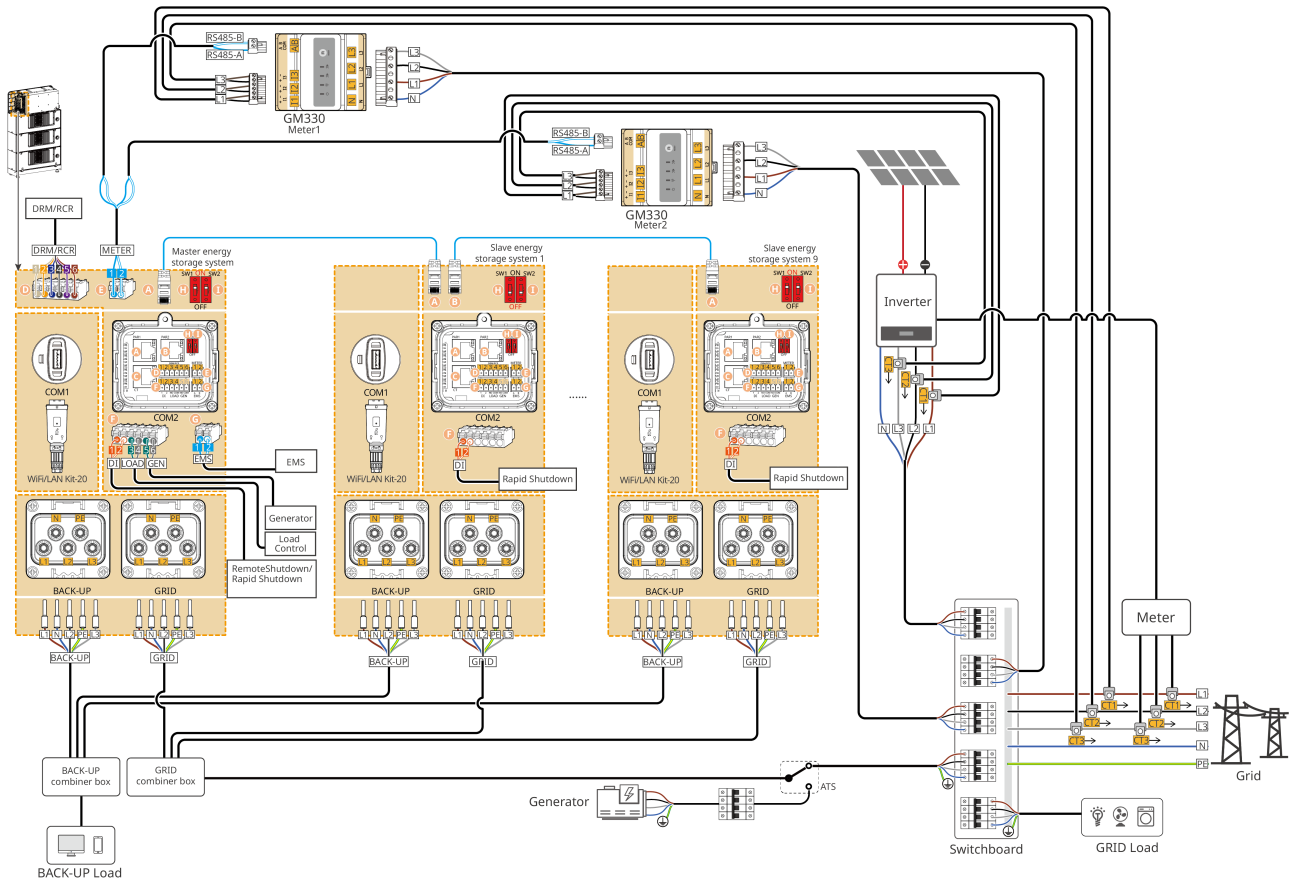

ESA3NET0029

For system coupling scenarios, the parallel connection with other meters can be wired by referring to the general parallel system scenarios. The grid-tied inverter wiring can be done by referring to the single-unit coupling scenario.

### 5.3 Preparing Materials



- Do not connect loads between the inverter and the AC switch directly connected to the inverter.
- Each inverter must be equipped with an AC output circuit breaker. Multiple inverters cannot be connected to one AC circuit breaker simultaneously.
- To ensure that the inverter can safely disconnect from the grid in case of abnormalities, please connect an AC circuit breaker on the AC side of the inverter. Select a suitable AC circuit breaker according to local regulations.
- When the inverter is powered on, the BACK-UP AC port is live. If maintenance is required on the BACK-UP Loads, please power off the inverter; otherwise, it may cause electric shock.
- For cables used in the same system, it is recommended that the following cable conductor material, cross-sectional area, length, etc., be consistent.
  - Inverter's BACK-UP AC cable
  - Inverter's GRID AC cable
- The inverter supports connecting to a generator via an ATS switch to achieve switching between grid and generator power supply. The ATS switch is by default connected to the grid.

### 5.3.1 Preparing Breakers

No.	breaker	Recommended Specifications	Acquisition Method	Remarks
1	GRID breaker BACK-UP breaker	Recommendations for partial backup scenarios are as follows: <ul style="list-style-type: none"> <li>• Nominal Voltage <math>\geq 230V_{ac}</math></li> <li>• Nominal current requirements are as follows:               <ul style="list-style-type: none"> <li>◦ GW5K-ETA-G20: 20A</li> <li>◦ GW6K-ETA-G20: 20A</li> <li>◦ GW8K-ETA-G20: 20A</li> <li>◦ GW9.999K-ETA-G20: 32A</li> </ul> </li> </ul>	Self-supplied	During actual selection, a breaker that meets local installation regulations can also be chosen based on the actual operating current.

No.	breaker	Recommended Specifications	Acquisition Method	Remarks
		<ul style="list-style-type: none"> <li>◦ GW10K-ETA-G20: 32A</li> <li>◦ GW12K-ETA-G20: 40A</li> <li>◦ GW15K-ETA-G20: 50A</li> <li>◦ GW20K-ETA-G20: 50A</li> <li>◦ GW25K-ETA-G20: 63A</li> <li>◦ GW29.999K-ETA-G20: 80A</li> <li>◦ GW30K-ETA-G20: 80A</li> <li>◦ GW5K-BTA-G20: 20A</li> <li>◦ GW6K-BTA-G20: 20A</li> <li>◦ GW8K-BTA-G20: 20A</li> <li>◦ GW9.999K-BTA-G20: 32A</li> <li>◦ GW10K-BTA-G20: 32A</li> <li>◦ GW12K-BTA-G20: 40A</li> <li>◦ GW15K-BTA-G20: 50A</li> <li>◦ GW20K-BTA-G20: 50A</li> <li>◦ GW25K-BTA-G20: 63A</li> <li>◦ GW29.999K-BTA-G20: 80A</li> <li>◦ GW30K-BTA-G20: 80A</li> </ul> <p>Recommendations for whole-house backup scenarios are as follows:</p> <ul style="list-style-type: none"> <li>• Nominal Voltage <math>\geq 230V_{ac}</math></li> <li>• Nominal current requirements are as follows: <ul style="list-style-type: none"> <li>◦ GW5K-ETA-G20: 63A</li> <li>◦ GW6K-ETA-G20: 63A</li> <li>◦ GW8K-ETA-G20: 63A</li> </ul> </li> </ul>		

No.	breaker	Recommended Specifications	Acquisition Method	Remarks
		<ul style="list-style-type: none"> <li>◦ GW9.999K-ETA-G20: 80A</li> <li>◦ GW10K-ETA-G20: 80A</li> <li>◦ GW12K-ETA-G20: 80A</li> <li>◦ GW15K-ETA-G20: 100A</li> <li>◦ GW20K-ETA-G20: 100A</li> <li>◦ GW25K-ETA-G20: 125A</li> <li>◦ GW29.999K-ETA-G20: 125A</li> <li>◦ GW30K-ETA-G20: 125A</li> <li>◦ GW5K-BTA-G20: 63A</li> <li>◦ GW6K-BTA-G20: 63A</li> <li>◦ GW8K-BTA-G20: 63A</li> <li>◦ GW9.999K-BTA-G20: 80A</li> <li>◦ GW10K-BTA-G20: 80A</li> <li>◦ GW12K-BTA-G20: 80A</li> <li>◦ GW15K-BTA-G20: 100A</li> <li>◦ GW20K-BTA-G20: 100A</li> <li>◦ GW25K-BTA-G20: 125A</li> <li>◦ GW29.999K-BTA-G20: 125A</li> <li>◦ GW30K-BTA-G20: 125A</li> </ul> <p>Note: If the inverter BACK-UP port is not used, the GRID breaker can be selected based on the maximum grid-tie current.</p>		
2	ATS Switch	The specifications of the ATS switch and the GRID breaker are consistent for the same model.	Self-supplied	

No.	breaker	Recommended Specifications	Acquisition Method	Remarks
3	RCD	<p>RCD Device Installation and RCD Specification Selection: It is recommended to externally connect a Type A RCD with a residual current trip level <math>\geq 300\text{mA}</math> to the AC output side of the inverter (inverter capacity <math>&lt; 30\text{kVA}</math>, select a residual current operating level of <math>300\text{mA}</math>; inverter capacity <math>\geq 30\text{kVA}</math>, select a residual current operating level of <math>10\text{mA/kVA}</math>). Alternatively, select an appropriate RCD specification based on local regulatory requirements.</p>	Self-supplied	-
4	(Optional) Manual Changeover Switch	<p>Nominal Voltage <math>\geq 230\text{Vac}</math> Nominal current requirements are as follows:</p> <ul style="list-style-type: none"> <li>• GW5K-ETA-G20, GW6K-ETA-G20, GW8K-ETA-G20, GW9.999K-ETA-G20, GW10K-ETA-G20, GW12K-ETA-G20, GW15K-ETA-G20, GW20K-ETA-G20, GW5K-BTA-G20, GW6K-BTA-G20, GW8K-BTA-G20, GW9.999K-BTA-G20, GW10K-BTA-G20, GW12K-BTA-G20, GW15K-BTA-G20, GW20K-BTA-G20: 63A</li> <li>• GW25K-ETA-G20, GW29.999K-ETA-G20, GW30K-ETA-G20, GW25K-BTA-G20, GW29.999K-BTA-G20, GW30K-BTA-G20: 80A</li> </ul>	<ul style="list-style-type: none"> <li>• Self-supplied</li> <li>• Shipped with the inverter (Australia only)</li> </ul>	<ul style="list-style-type: none"> <li>• For use in single-unit scenarios only.</li> <li>• During actual selection, an appropriate manual transfer switch can also be chosen based on local regulations.</li> </ul>

### 5.3.2 Preparing Cables

No.	Cable	Recommended Specification	Acquisition Method
1	Inverter Enclosure Protective Grounding Cable	<ul style="list-style-type: none"> <li>• Single-core outdoor copper cable</li> <li>• Conductor cross-sectional area:               <ul style="list-style-type: none"> <li>◦ GW5K-ETA-G20, GW6K-ETA-G20, GW8K-ETA-G20, GW5K-BTA-G20, GW6K-BTA-G20, GW8K-BTA-G20: 4-6mm<sup>2</sup></li> <li>◦ GW9.999K-ETA-G20, GW10K-ETA-G20, GW12K-ETA-G20, GW15K-ETA-G20, GW20K-ETA-G20, GW9.999K-BTA-G20, GW10K-BTA-G20, GW12K-BTA-G20, GW15K-BTA-G20, GW20K-BTA-G20: 6-10 mm<sup>2</sup></li> <li>◦ GW25K-ETA-G20, GW29.999K-ETA-G20, GW30K-ETA-G20, GW25K-BTA-G20, GW29.999K-BTA-G20, GW30K-BTA-G20: 10-16 mm<sup>2</sup></li> </ul> </li> </ul>	Customer-supplied
2	PV DC Cable	<ul style="list-style-type: none"> <li>• Industry-standard outdoor photovoltaic cable</li> <li>• Conductor cross-sectional area: 4mm<sup>2</sup>-6mm<sup>2</sup></li> <li>• Cable outer diameter: 5.9mm-8.8mm</li> </ul>	Customer-supplied

No.	Cable	Recommended Specification	Acquisition Method
3	AC Cable	<ul style="list-style-type: none"> <li>• Inverter AC input/output cable (BACK UP/GRID):</li> <li>• Conductor cross-sectional area:               <ul style="list-style-type: none"> <li>◦ GW5K-ETA-G20, GW6K-ETA-G20, GW8K-ETA-G20, GW5K-BTA-G20, GW6K-BTA-G20, GW8K-BTA-G20: 4-6mm<sup>2</sup></li> <li>◦ GW9.999K-ETA-G20, GW10K-ETA-G20, GW12K-ETA-G20, GW9.999K-BTA-G20, GW10K-BTA-G20, GW12K-BTA-G20: 6-10mm<sup>2</sup></li> <li>◦ GW15K-ETA-G20, GW20K-ETA-G20, GW15K-BTA-G20, GW20K-BTA-G20: 10-16mm<sup>2</sup></li> <li>◦ GW25K-ETA-G20, GW29.999K-ETA-G20, GW30K-ETA-G20, GW25K-BTA-G20, GW29.999K-BTA-G20, GW30K-BTA-G20: 16-25mm<sup>2</sup></li> </ul> </li> <li>• Multi-core outdoor copper cable outer diameter:               <ul style="list-style-type: none"> <li>◦ GW5K-ETA-G20, GW6K-ETA-G20, GW8K-ETA-G20, GW9.999K-ETA-G20, GW10K-ETA-G20, GW12K-ETA-G20, GW5K-BTA-G20, GW6K-BTA-G20, GW8K-BTA-G20, GW9.999K-BTA-G20, GW10K-BTA-G20, GW12K-BTA-G20, GW15K-ETA-G20, GW20K-ETA-G20, GW15K-BTA-G20, GW20K-BTA-G20: 10-26mm</li> <li>◦ GW25K-ETA-G20, GW29.999K-ETA-G20, GW30K-ETA-G20, GW25K-BTA-G20, GW29.999K-BTA-G20, GW30K-BTA-G20: 18-30mm</li> </ul> </li> </ul>	Customer-supplied

No.	Cable	Recommended Specification	Acquisition Method
4	Smart Meter Power Cable	<ul style="list-style-type: none"> <li>• Outdoor copper cable</li> <li>• Conductor cross-sectional area: 1mm<sup>2</sup></li> </ul>	Customer-supplied
5	Meter RS485 Communication cable	<ul style="list-style-type: none"> <li>• Shielded twisted pair cable</li> <li>• Conductor cross-sectional area: 0.2mm<sup>2</sup>-0.4mm<sup>2</sup></li> </ul>	Customer-supplied
6	EMS or Charging Pile RS485 Communication cable		
7	Remote Shutdown	<ul style="list-style-type: none"> <li>• Shielded cable meeting local standards</li> <li>• Conductor cross-sectional area: 0.2mm<sup>2</sup>-0.4mm<sup>2</sup></li> <li>• Cable outer diameter: 5mm-8mm</li> </ul>	Customer-supplied
8	Load Control and Generator Control DO Communication cable		
9	RCR/DRED/14a Signal Cable		
10	CT Communication cable	Standard straight-through Ethernet cable: CAT 5E or higher specification standard shielded Ethernet cable and RJ45 connector	Customer-supplied

No.	Cable	Recommended Specification	Acquisition Method
11	Inverter Parallel Communication cable	Standard straight-through Ethernet cable: <ul style="list-style-type: none"> <li>• RJ45 shielded connector</li> <li>• CAT 5E or higher specification straight-through shielded Ethernet cable               <ul style="list-style-type: none"> <li>◦ CAT 5E or CAT 6E recommended length not exceeding 5 meters</li> <li>◦ CAT 7E recommended length not exceeding 10 meters</li> </ul> </li> </ul>	Customer-supplied

## 5.4 Connecting the PE cable

### WARNING

- The protective grounding of the chassis cannot replace the protective ground wire of the AC output port. When wiring, ensure the protective ground wires at both locations are reliably connected.
- To improve the corrosion resistance of the terminal, it is recommended to apply silicone or paint over the external part of the grounding terminal for protection after the protective ground wire connection installation is completed.
- When installing the equipment, the protective ground wire must be installed first; when removing the equipment, the protective ground wire must be removed last.
- The battery grounding is integrated into the blind-mating connector connected to the inverter. The system is uniformly grounded through the inverter, so no separate grounding operation is required for the battery during installation. If there is a requirement for split expansion, please separately ground the expansion battery pack.

Energy storage system grounding:

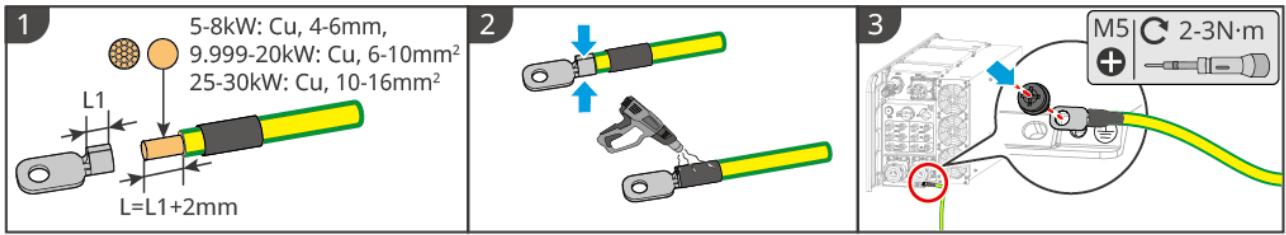

ESA20ELC0031

Expansion battery pack grounding:

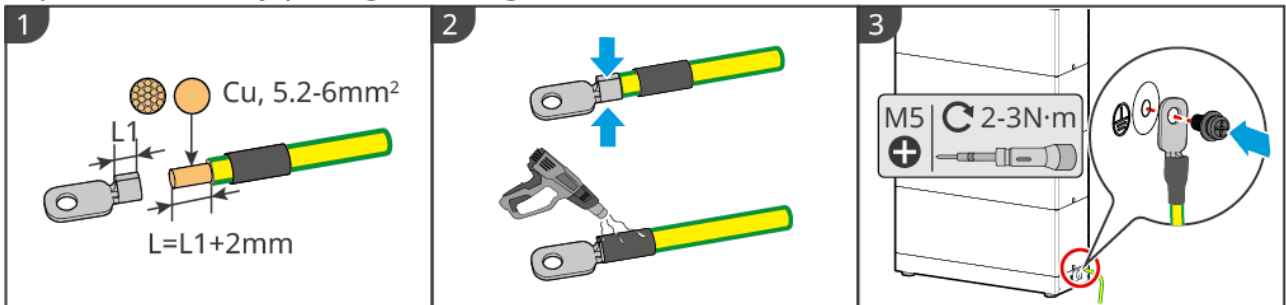

BAT20ELC0003

## 5.5 Connecting the PV Cable

### **⚠ DANGER**

- Do not connect the same PV string to multiple inverters, as this may cause inverter damage.
- Before connecting the PV string to the inverter, confirm the following information. Failure to do so may cause permanent damage to the inverter, and in severe cases, may lead to fire, resulting in personal injury and property loss.
  1. Ensure the maximum short-circuit current and Max. Input Voltage for each MPPT are within the inverter's allowable range.
  2. Ensure the positive pole of the PV string is connected to the inverter's PV+ terminal, and the negative pole is connected to the inverter's PV- terminal.

### **⚠ WARNING**

- PV string output does not support grounding. Before connecting the PV string to the inverter, ensure the minimum insulation resistance to ground of the PV string meets the minimum insulation impedance requirement ( $R = \text{Max. Input Voltage} / 30\text{mA}$ ).
- After completing the DC cable connection, ensure the cable connections are tight and secure, with no looseness.
- Use a multimeter to measure the positive and negative poles of the DC cable to ensure correct polarity (no reverse connection) and that the voltage is within the allowable range.

### NOTICE

- The two PV strings within each MPPT should use the same model, the same number of panels, and the same tilt and azimuth angles to ensure maximum efficiency.
- Connecting PV cables applies only to the ETA model; the BTA model does not have PV connection ports.

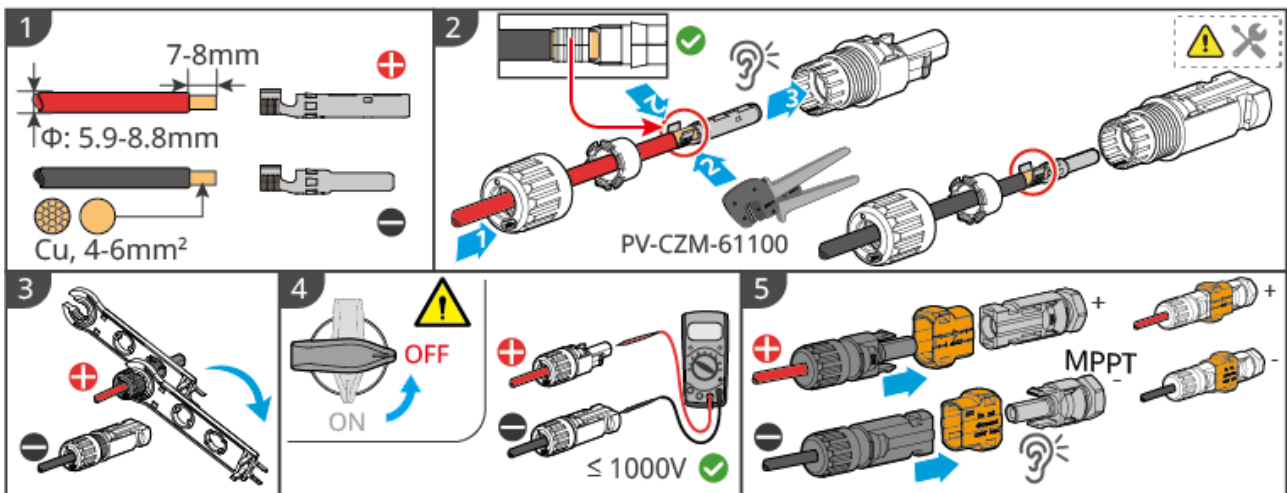

To disassemble the PV terminal, please refer to the following steps:

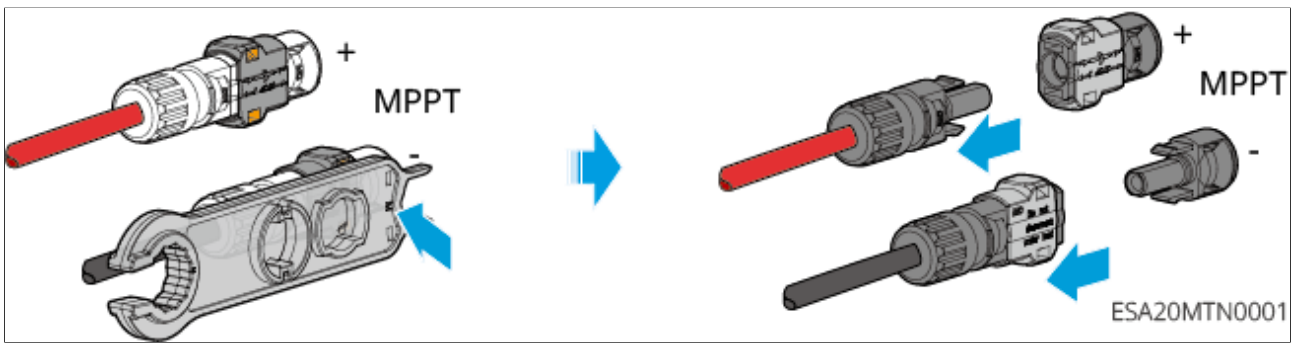

## 5.6 Expansion line connection for Battery

**! DANGER**

- Do not connect any load between Inverter and Battery.
- When Connecting the Battery Cable, use insulated tools to prevent accidental electric shock or Battery Short Circuit.
- Please ensure that Battery open-circuit voltage is within the allowable range of Inverter.
- Between Battery and Battery, please configure DC Switch according to local laws and regulations.
- Inverter heat sink surface and surrounding areas are prohibited from wiring to prevent overheating damage to the wire harness.

### energy storage system Expansion Overview

A1: Base shipped with Inverter

A2: Installation Base with parallel port

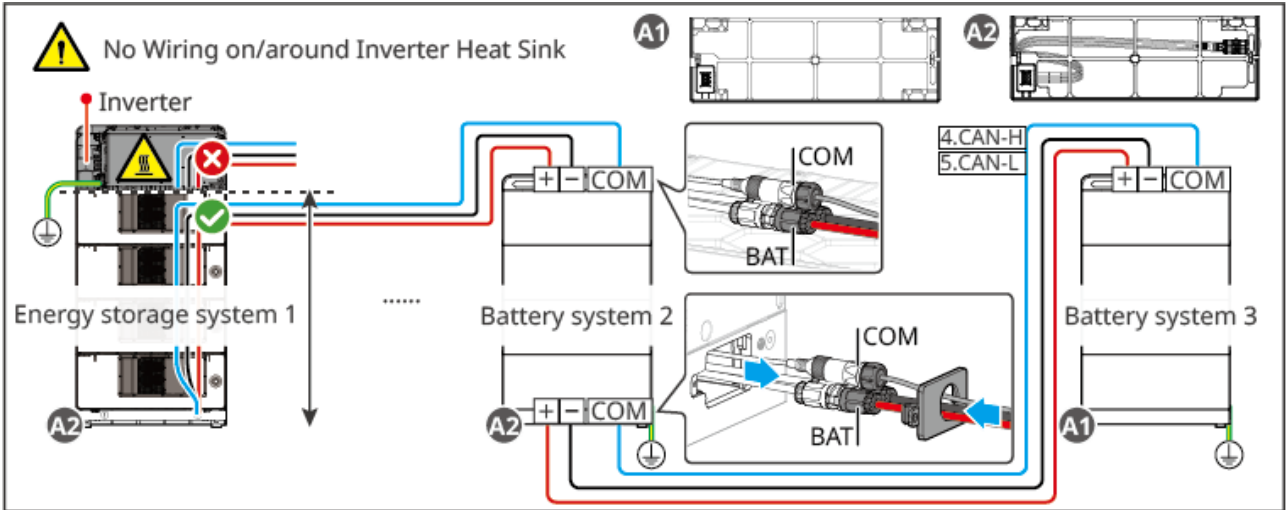

ESA20ELC0025

### Battery system Expansion Harness Manufacturing Method

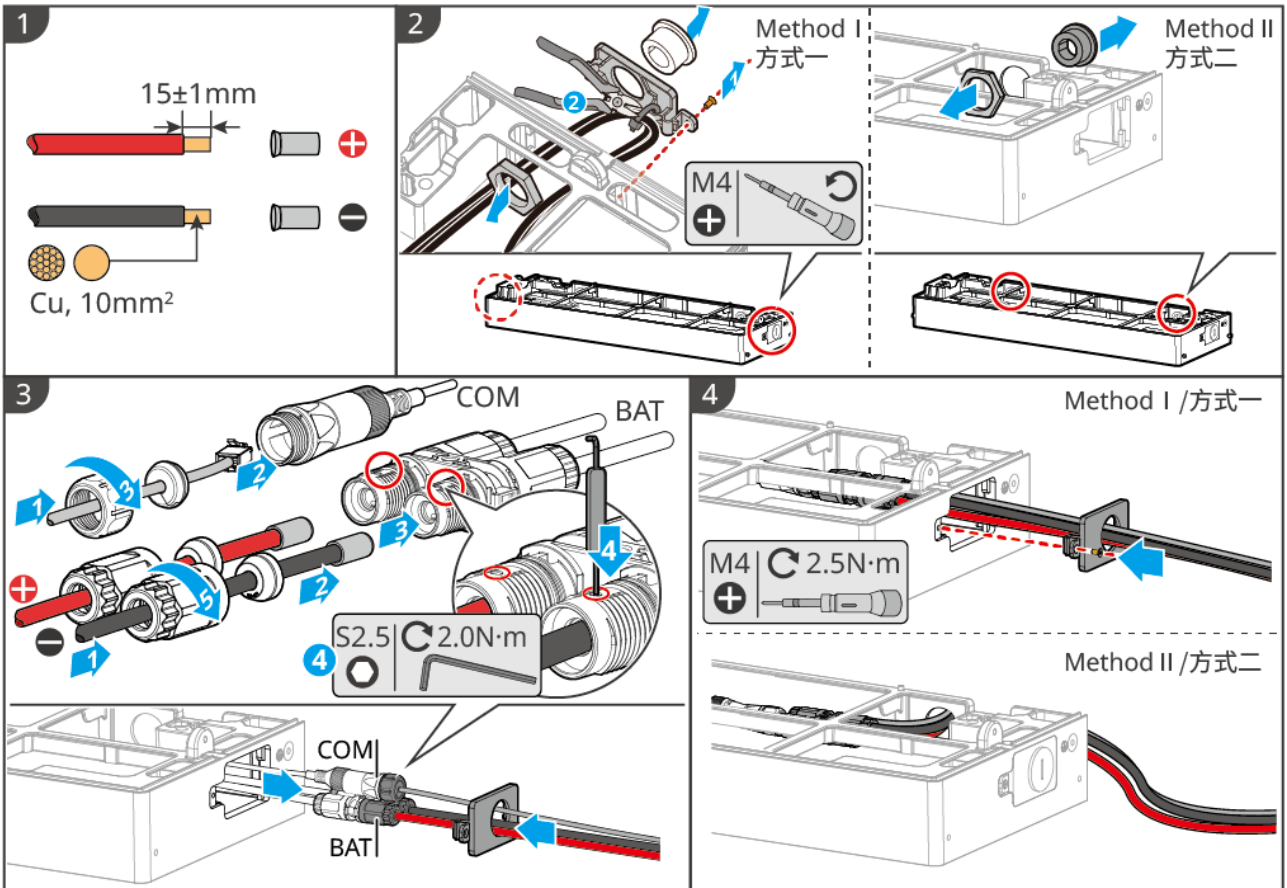

BAT20ELC0004

### Battery Expansion Harness Disassembly Method

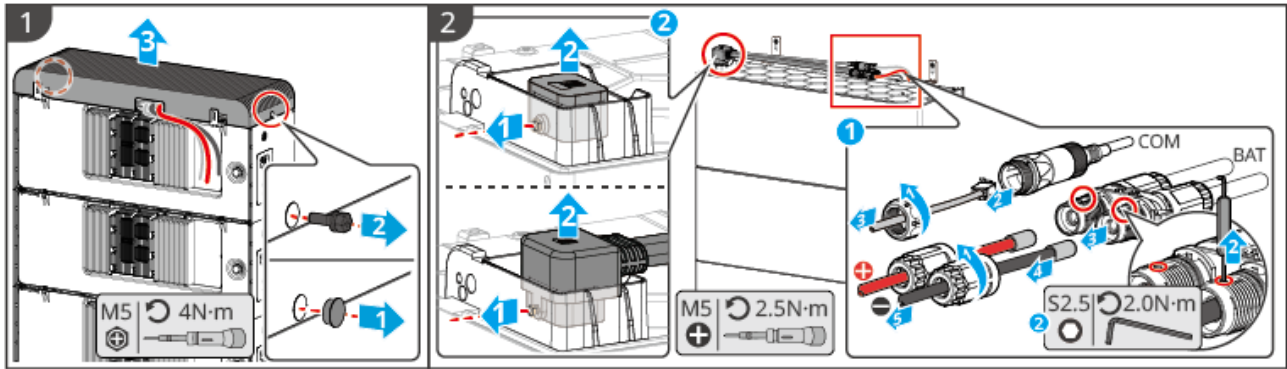

BAT20INT0007

## 5.7 Connecting the AC Cable

### WARNING

- The inverter has an integrated Residual Current Monitoring Unit (RCMU) to prevent residual current from exceeding the specified limit. When the inverter detects a leakage current greater than the permitted value, it will quickly disconnect from the grid.
- During wiring, ensure the AC cables are correctly matched to the "BACKUP" and "GRID" ground terminals of the AC terminal block. Incorrect cable connection may cause equipment damage.
- Ensure the wire cores are fully inserted into the terminal connection holes with no exposed part.
- Ensure the insulation plate at the AC terminal block is securely fastened and not loose.
- Ensure all cable connections are tight. Otherwise, overheating of the terminals during operation may cause equipment damage.

## NOTICE

- When crimping AC cables, it is recommended to use a crimping tool with a hexagonal (or more sides) crimp shape.
- After system installation is complete and wiring is confirmed correct, under normal operation, the home's critical loads should be powered by the energy storage inverter's BACK-UP port.
- After AC wiring is completed, please set the manual transfer switch to the "BACK-UP" position to engage. The fixed lock bracket supplied with the manual transfer switch can be installed as needed. If installation is required, to facilitate the installation and removal of the padlock accessory, reserve at least 35mm of space on each side of the switch.

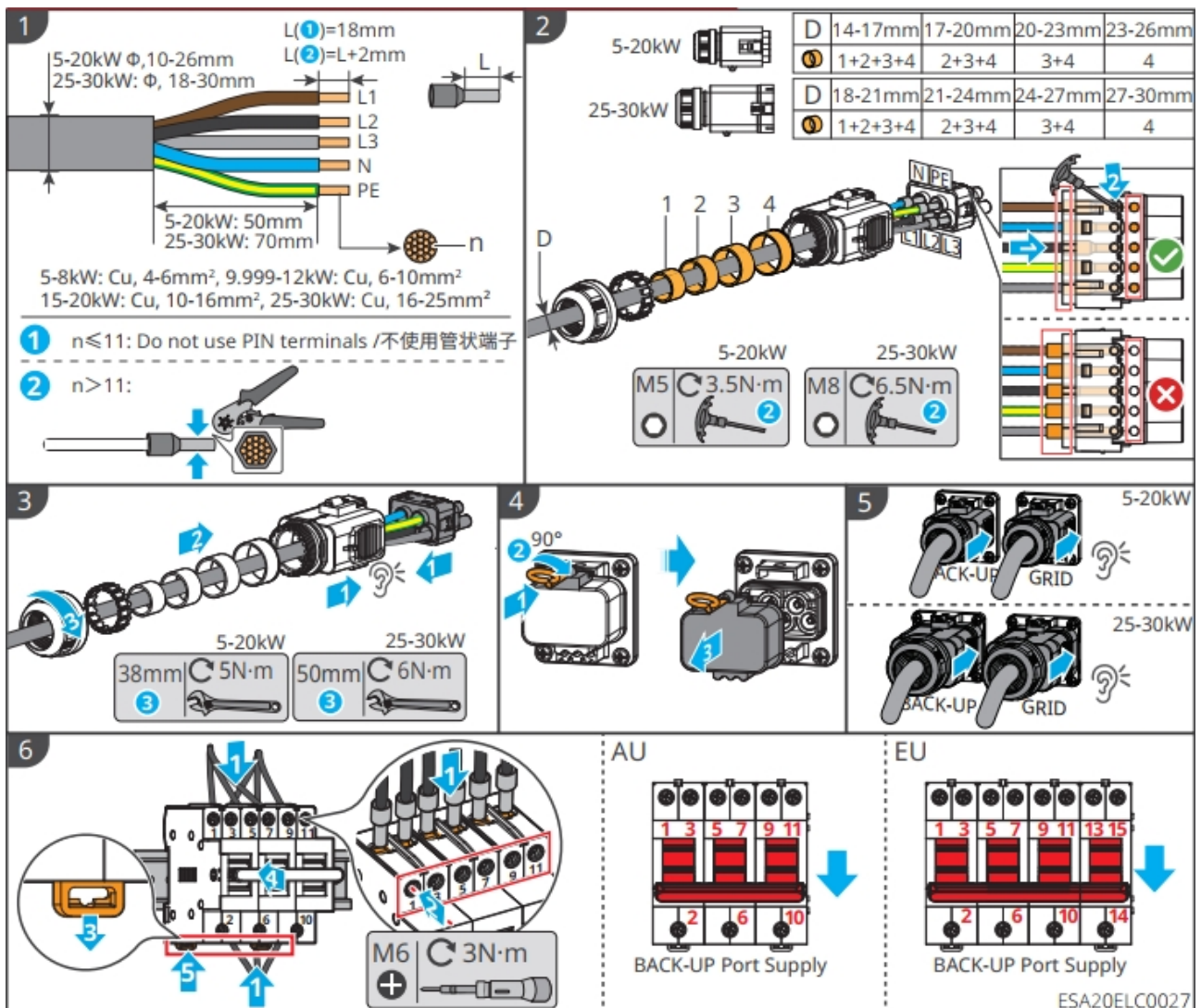

(Optional) Install the manual transfer switch lock

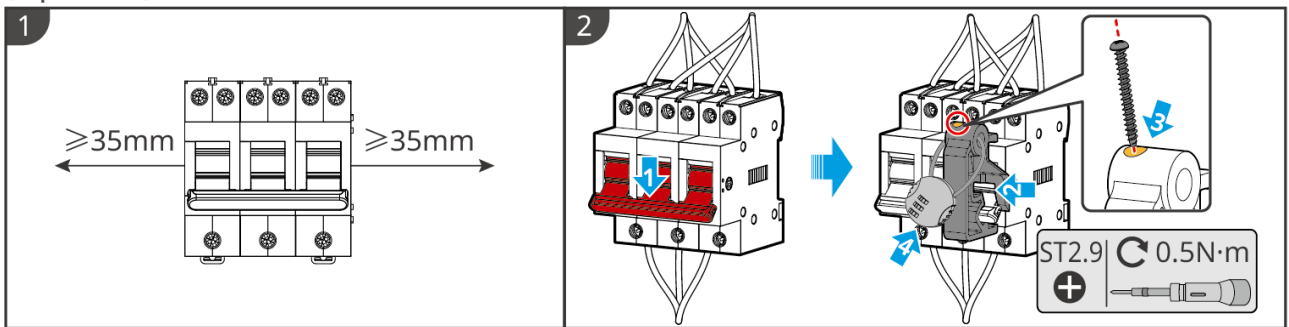

ESA20ELC0033

If you need to disassemble the AC terminal, please refer to the following steps:

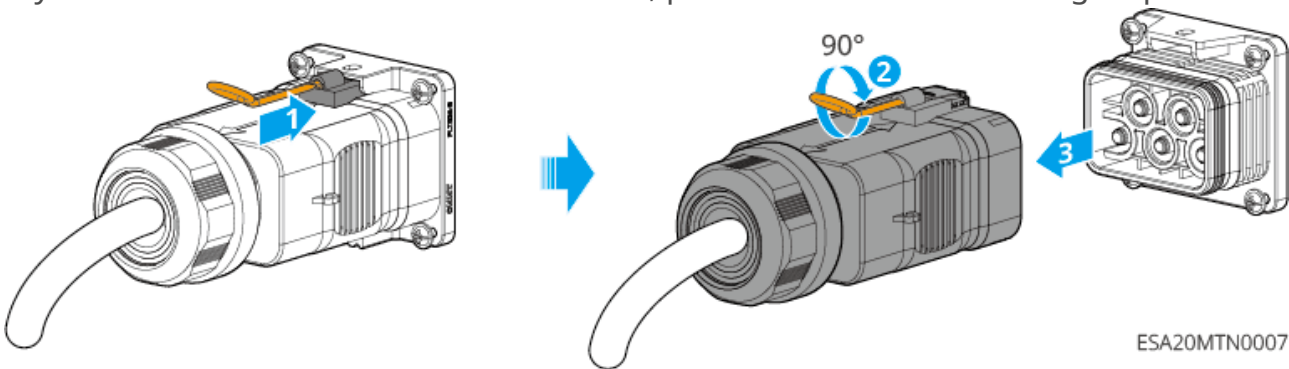

ESA20MTN0007

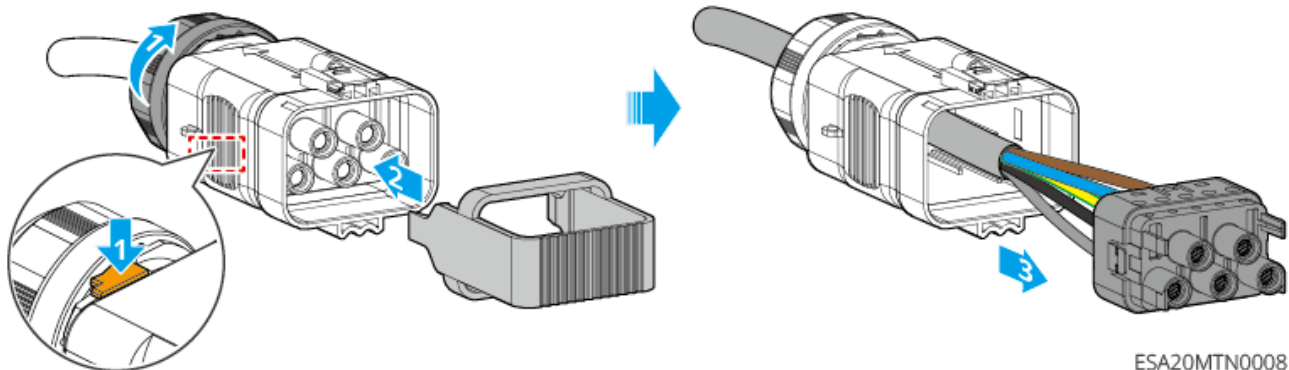

ESA20MTN0008

## 5.8 Connecting the Meter Cable

## NOTICE

- If there is a need for multiple inverters to be connected in parallel for networking, please consult the manufacturer to purchase a meter separately.
- Please ensure that the CT connection direction and phase sequence are correct; otherwise, it may lead to incorrect monitoring data.
- Ensure that all cables are connected correctly, tightly, and without looseness. Improper wiring may cause poor contact or damage to the meter.
- In areas with lightning risks, if the meter cable length exceeds 10m and the cables are not laid with grounded metal conduits, it is recommended to install external lightning protection devices.

### GM330 Meter Wiring

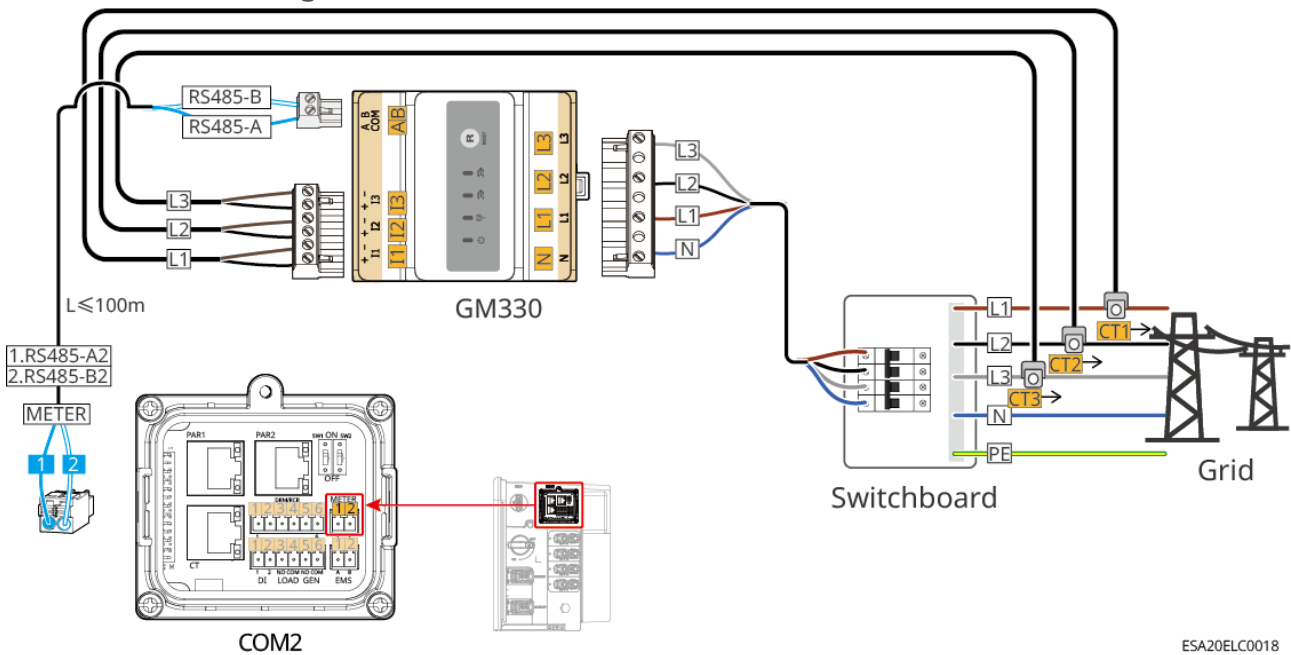

ESA20ELC0018

### GMK330 Meter Wiring

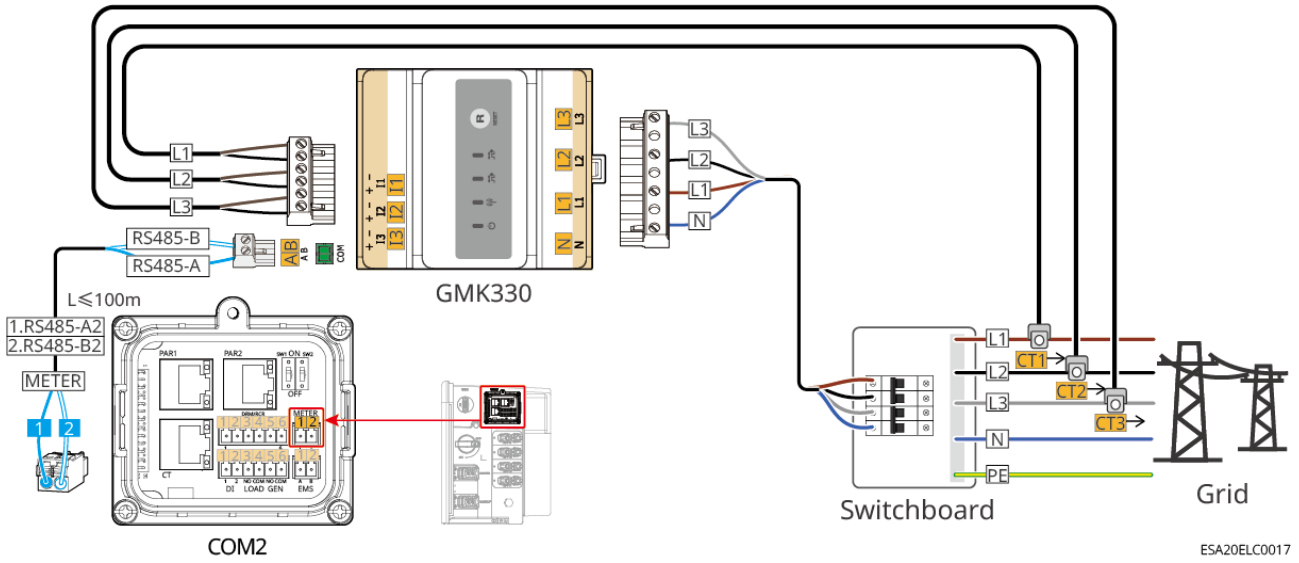

### Wiring Steps

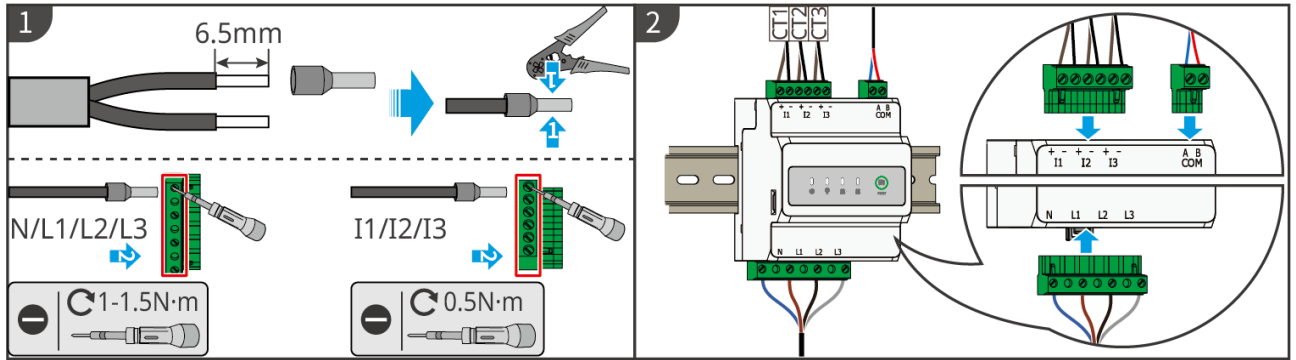

### Install CT (Type One)

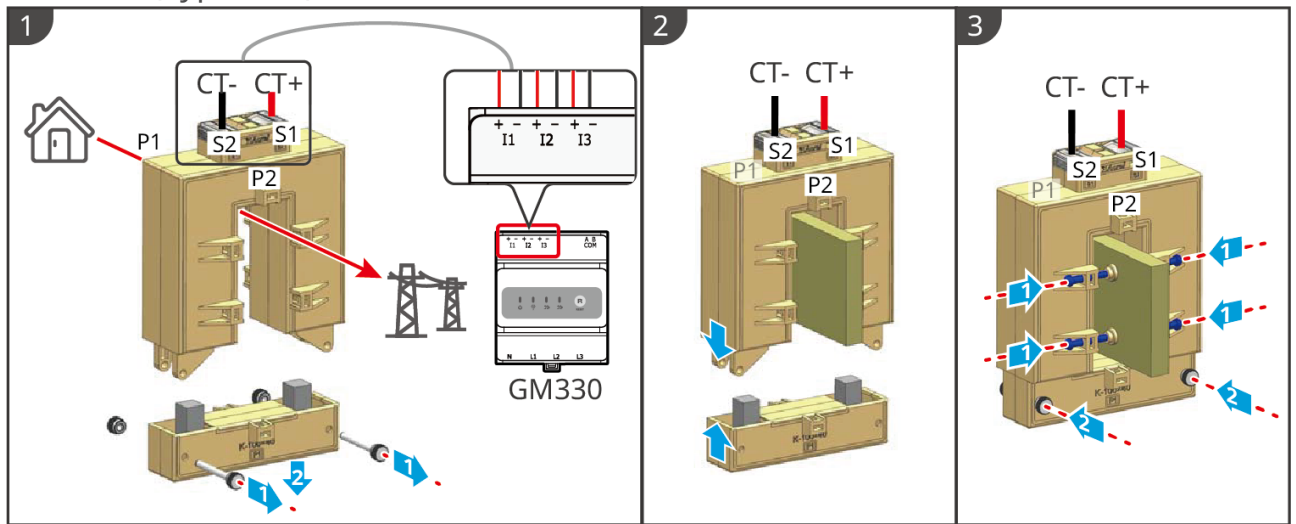

### Install CT (Type Two)

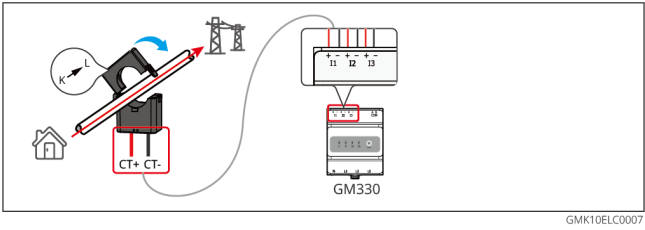

# 5.9 Connecting the Inverter Communication Cable

## NOTICE

- To ensure the meter and CT function properly, please ensure the following: the CT must be connected to the matching phase line, with CT1 connected to L1, CT2 connected to L2, and CT3 connected to L3.
- When using the Inverter's built-in meter, please use the CTs shipped with the unit.
- If you need to use the DRED, RCR, or remote shutdown function, please enable this function in the SEMS+ App after completing the wiring.
- If the Inverter is not connected to a DRED device or a remote shutdown device, do not enable this function in the SEMS+ App, otherwise the Inverter will be unable to operate in grid-tied mode.
- In a parallel system, to implement the DRED or RCR function, only connect the DRED or RCR communication cable to the master Inverter.
- To maintain the Inverter's waterproof rating, do not remove the waterproof plugs from unused communication ports on the Inverter.
- For the Inverter's DO signal communication port, the dry contact signal specifications are:  $\text{Max} \leq 24\text{Vdc}$ , 1A.
- The Inverter's communication functions are optional; please select them according to your actual usage scenario.
- The Inverter supports connecting via Bluetooth, WiFi, or LAN to a mobile phone or WEB interface to set device parameters, view device operation information and error messages, and stay informed of the system status.
- In a single-unit system, the installation of a WiFi/LAN Kit-20 or 4G Kit-CN smart communication stick is supported.
- In a parallel system, both the master and slave Inverters need to have a WiFi/LAN Kit-20 smart communication stick installed for networking.
- In a parallel system, the DIP switches on the first and last Inverters must be set to the ON position, while the switches on all other Inverters should be set to the OFF position.

### Communication Function Description

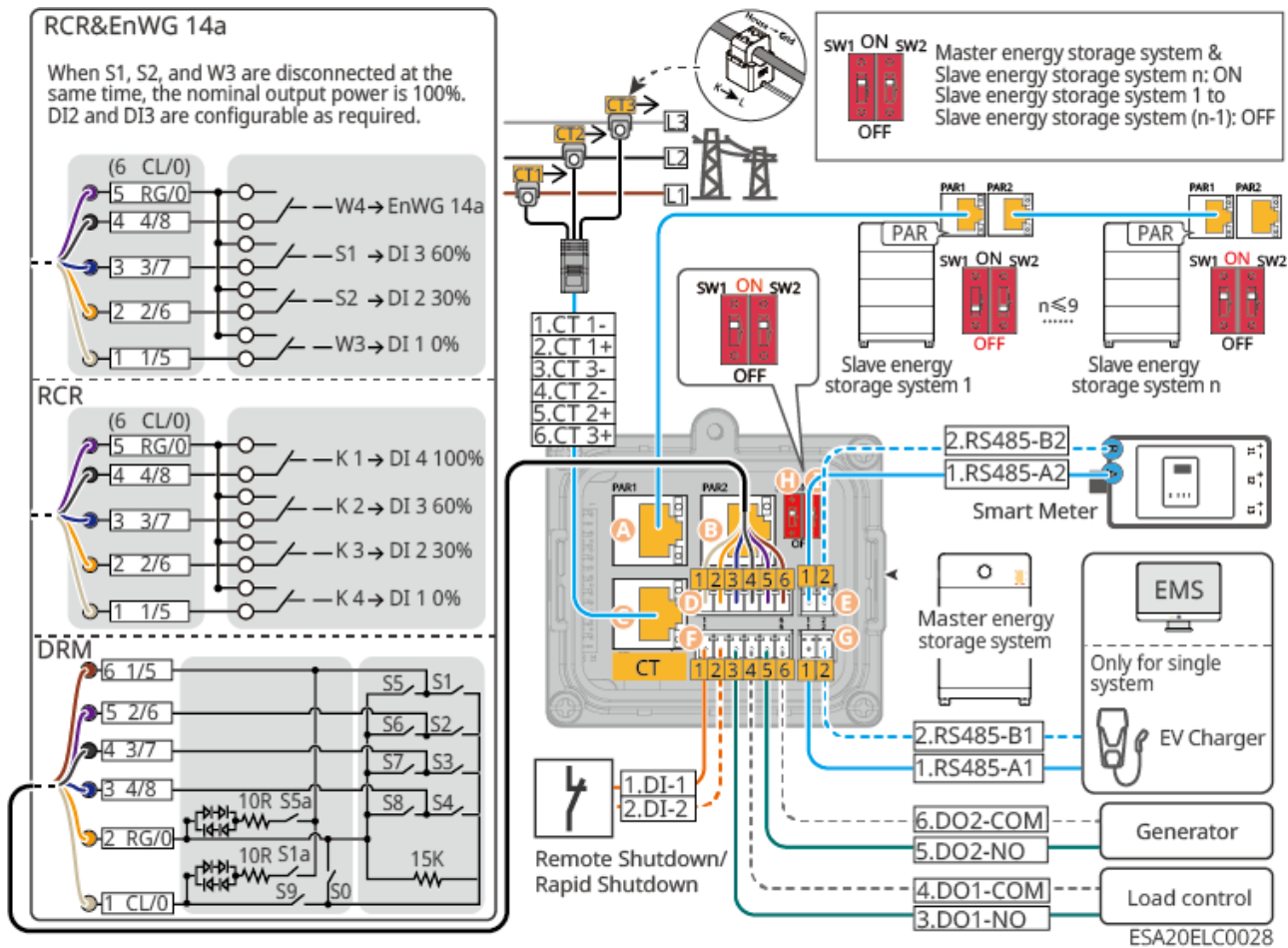

Port (Silkscreen)		Function	Description
A	PAR1	Parallel Communication Port 1	Parallel Communication Port. Please use CAT 5E or above standard network cable and RJ45 connector.
B	PAR2	Parallel Communication Port 2	
C	CT	CT Connection Port	Only when using the inverter's built-in meter, connect the CT communication cable.

Port (Silkscreen)		Function	Description
D	DRM/RCR	RCR, DRED or EnWG 14a Function Connection Port	<ul style="list-style-type: none"> <li>• RCR (Ripple Control Receiver): Provides RCR signal control port to meet the grid dispatch requirements in Europe.</li> <li>• DRED (Demand Response Enabling Device): Provides DRED signal control port to meet DERD certification requirements in regions like Australia.</li> <li>• EnWG (Energy Industry Act) 14a: All controllable loads need to accept grid emergency dimming. Grid operators can temporarily reduce the maximum grid power purchase of controllable loads to 4.2kW.</li> </ul>
E	METER	Meter Connection Port	Use RS485 communication to connect external smart meter.
F	DI	Remote Shutdown / Rapid Shutdown	<ul style="list-style-type: none"> <li>• External Remote Shutdown device, default is off.</li> <li>• In a Rapid Shutdown system, the Rapid Shutdown transmitter and receiver work together to achieve rapid system shutdown. The receiver maintains component output by receiving signals from the transmitter. The transmitter can be external or built into the inverter. In case of emergency, by enabling an external trigger device, the transmitter stops working, thereby shutting down the components.</li> </ul>

Port (Silkscreen)		Function	Description
	LOAD	load control	<ul style="list-style-type: none"> <li>• Supports connection to dry contact signals to achieve functions such as load control. DO contact capacity is 24V DC@1A, NO/COM normally open contacts.</li> <li>• Supports SG Ready heat pump access, controlling the heat pump via dry contact signals.</li> </ul>
	GEN	Generator Control Port	Supports connecting generator control signals to control generator start/stop. In microgrid scenarios, connecting generators is not supported.
G	EMS	EMS/Charging Pile Communication Port	<ul style="list-style-type: none"> <li>• Connect third-party EMS devices for energy control</li> <li>• Only in standalone scenarios, supports connecting GoodWe charging piles.</li> </ul>
H	SW1	-	-
I	SW2	-	-

### Method for Connecting the Communication Cable

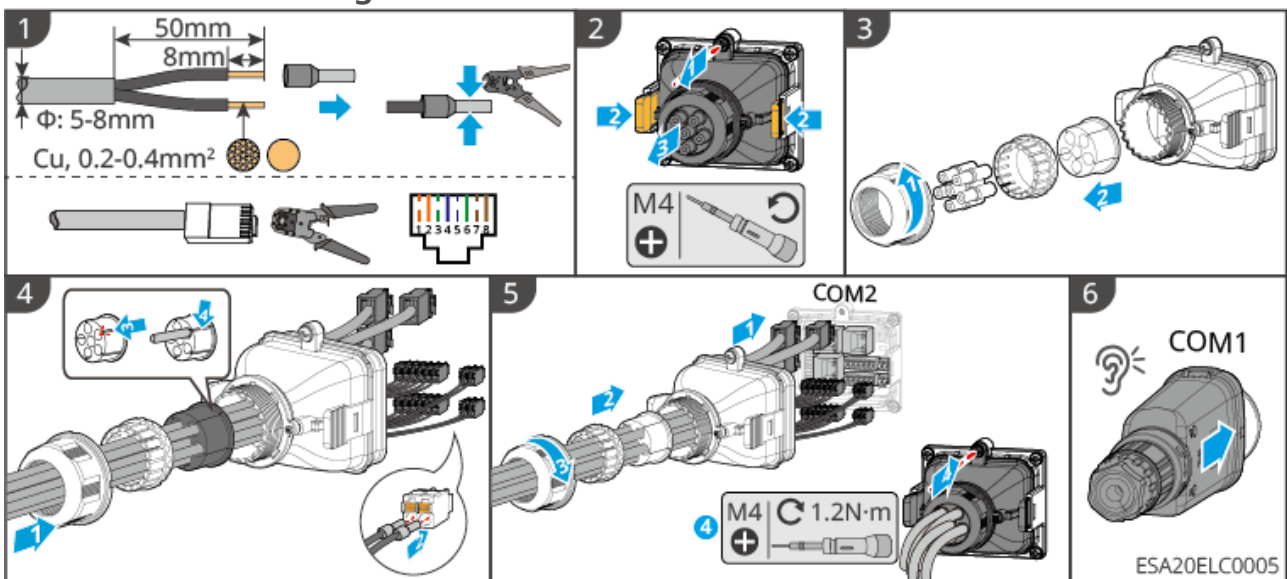

# 6 System Commissioning

## 6.1 Check Before Power ON

No.	Inspection items
1	The equipment is firmly installed, easy to operate and maintain, with sufficient space for ventilation and heat dissipation, and the environment is clean and tidy.
2	PE cable, DC cables, AC cables, and Communication cable are correctly and securely connected.
3	The cable ties meet the wiring requirements, are reasonably distributed, and show no signs of damage.
4	Unused through-holes and port must be reliably connected using the provided terminal accessories and properly sealed.
5	Ensure that all used wire feed-through holes are properly sealed.
6	The voltage and Frequency of the Inverter on-grid access point comply with the on-grid requirements.

## 6.2 Power ON

## WARNING

- Battery black start: When there is no PV power generation in the photovoltaic system and the grid is abnormal, if the inverter cannot work normally, the battery black start function can be used to force battery discharge to start the inverter. The inverter can enter off-grid mode operation, and the battery supplies power to the load.
- After the battery system is started, please ensure that the inverter and battery system communicate normally within 15 minutes. If the inverter and battery system cannot communicate normally, the battery system switch will automatically disconnect, and the battery system will be powered off.
- When the inverter is working normally, please set the manual transfer switch to the BACK-UP position to engage, and power the load from the inverter BACK-UP port.
- PV strings and “5” are only applicable to the ETA series.

## NOTICE

During the initial system power-on, it is recommended to perform a battery black start once. Close the battery power switch and briefly press the multifunction button on one of the batteries. Observe whether the inverter SOC indicator light illuminates. If the indicator light is on, it indicates the battery is connected properly, and you can proceed to close the DC switch of the inverter.

### **power on**

Single System Scenario:

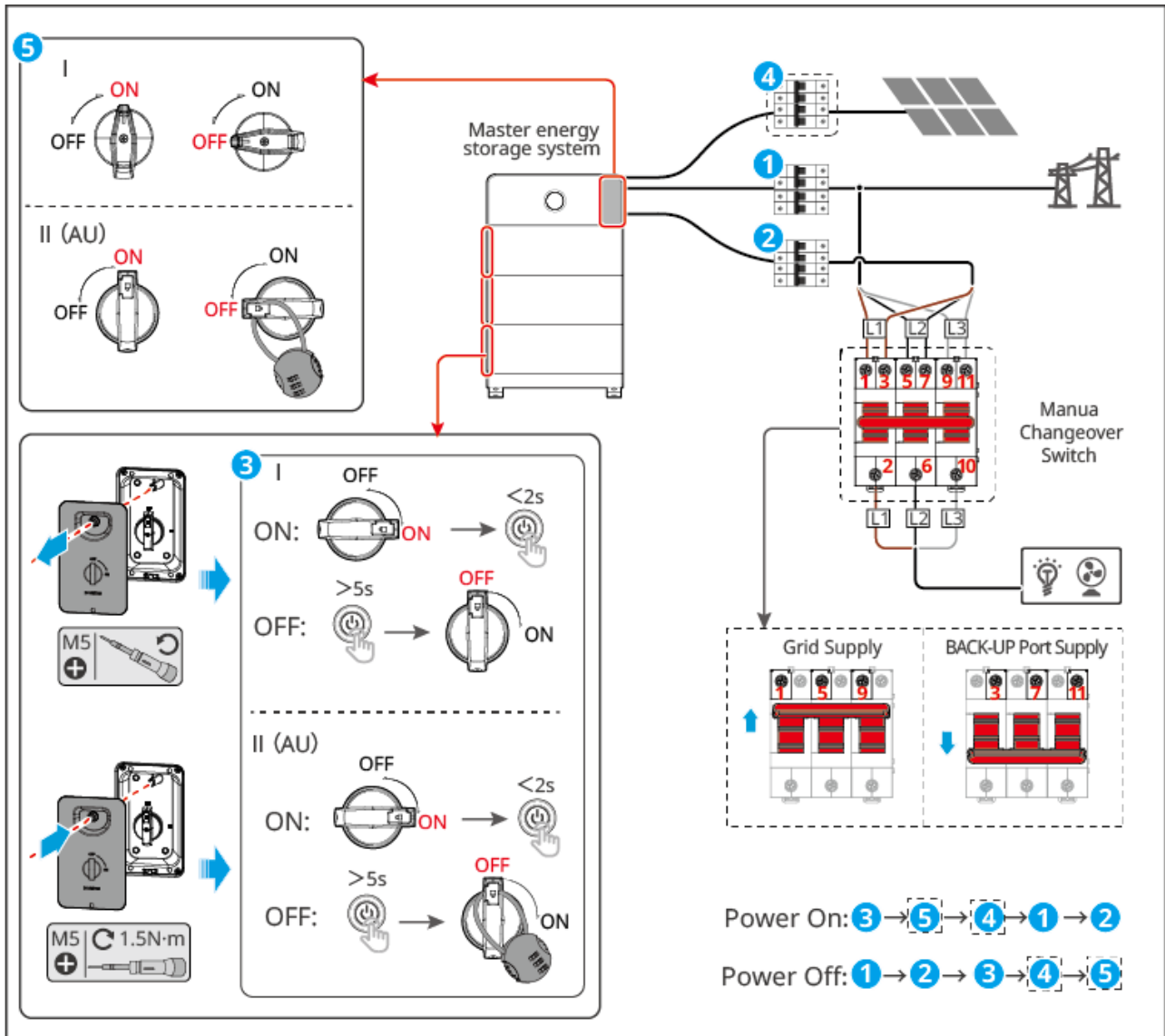

ESA20PWR0003

1. Close the battery power switch and briefly press the battery's multifunction button. When there are multiple batteries in the system, close the power switches of all batteries. Briefly pressing the multifunction button on any one battery will start all batteries.
2. Close the inverter's DC switch.
3. Close the breaker between the PV components and the inverter.
4. In a parallel system, close the GRID breaker.
5. Set the manual transfer switch to the BACK-UP position to engage it, supplying power to the loads from the BACK-UP port. Close the BACK-UP breaker.

parallel system:

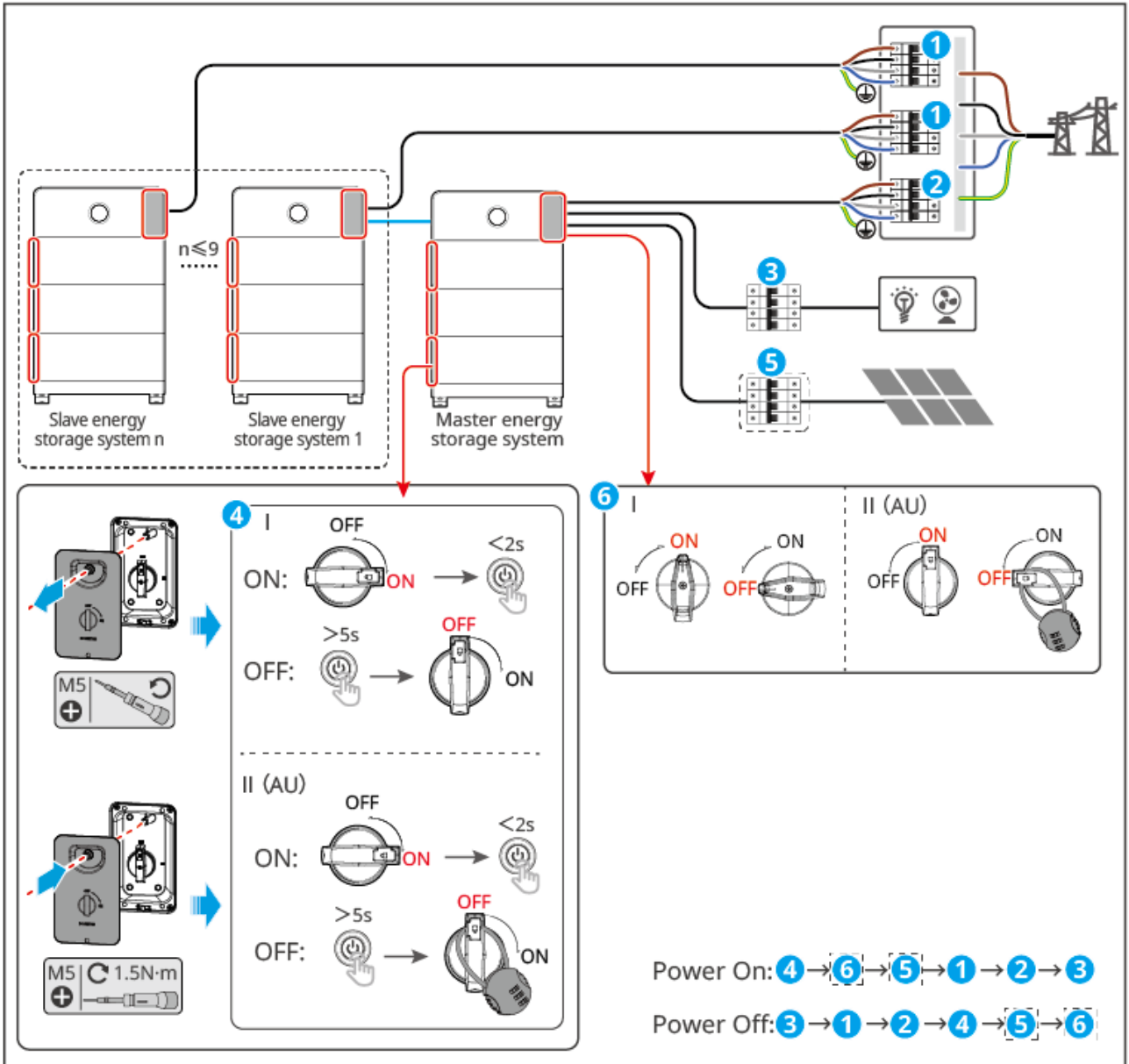

ESA20PWR0005

1. Close the battery power switch and briefly press the battery's multifunction button. When there are multiple batteries in the system, close the power switches of all batteries. Briefly pressing the multifunction button on any one battery will start all batteries.
2. Close the inverter's DC switch.
3. (Optional) Close the breaker between the PV components and the inverter.
4. Close the GRID breaker from the inverter.
5. Close the main inverter GRID breaker.
6. Close the BACK-UP breaker.

## Battery Black Start

1. Close the battery power switch. When there are multiple batteries in the system, close the power switches of all batteries.
2. Close the inverter's DC switch.
3. (Optional) Close the breaker between the PV components and the inverter.
4. Close the GRID breaker.
5. Close the BACK-UP breaker.
6. After all batteries are powered on separately, wait for 15 seconds, then press and hold the multifunction button on any one battery for 2 seconds to force the battery to discharge and activate the inverter.

## 6.3 Installing the Protective Cover

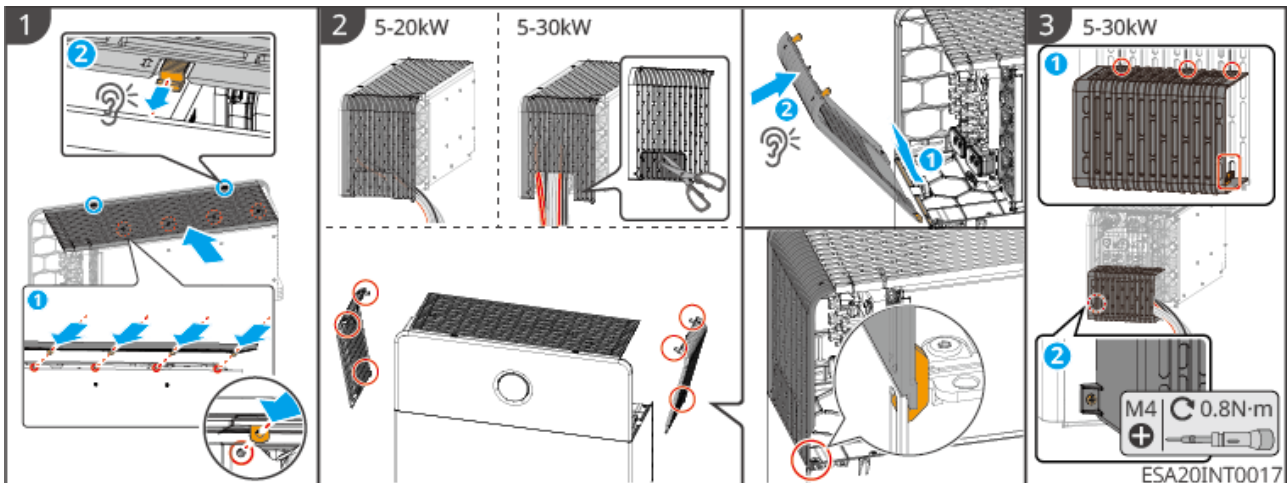

**Step 1:** Install the inverter top cover. Align the cover with the installation slot on the top of the inverter and slide it forward.

**Step 2:** Install the side cover. Place the side cover into the slot on the side of the battery and push it forward.

**Step 3:** (Optional) If using side cable routing, install the cable cover.



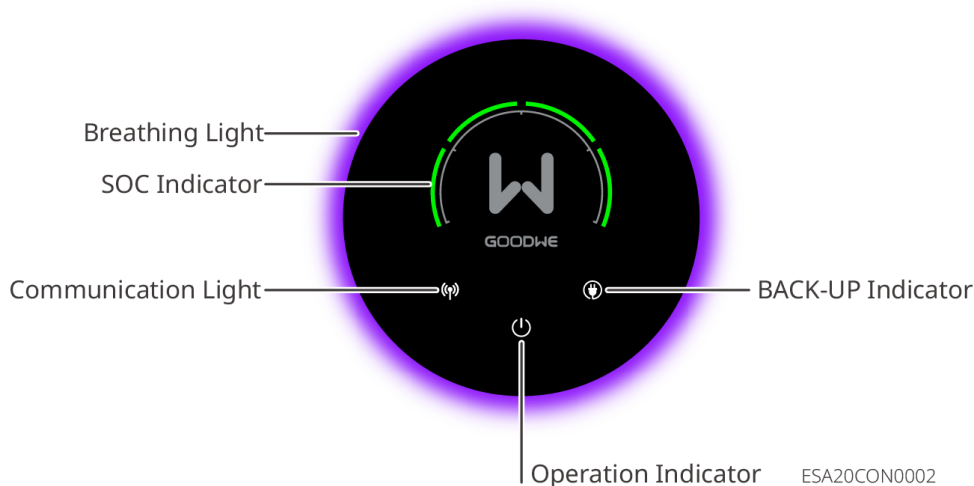

## 6.4 Indicators















### 6.4.1 Inverter Indicators



### Breathing Light:

- When the system is in an upgrade state: The Breathing Light is a green marquee light; the head of the marquee is brightest and the tail is dimmest. The length of the marquee and the upgrade percentage are influenced by the SEMS+ App settings and the device's operational status.
- Except during inverter upgrades, system faults, and inverter power-off states, the Breathing Light status is affected by the App settings in the SEMS+ App. For setup instructions, please refer to the SEMS+ App User Manual.

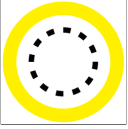
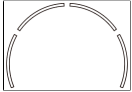
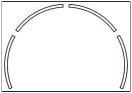
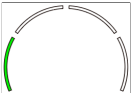
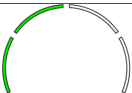
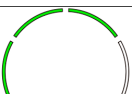
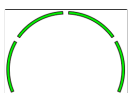

Indicator	Indicator Status	Breathing Light Status	Description
		<ul style="list-style-type: none"> <li>• 3min/Always On: Blue-purple chasing light stays on</li> </ul>	Inverter is powered on and in standby mode
		<ul style="list-style-type: none"> <li>• Always Off: Off</li> </ul>	Inverter is starting up and in self-test mode
		<ul style="list-style-type: none"> <li>• 3min: Blue-purple breathing for 3min then off</li> <li>• Always On via App: Blue-purple breathing stays on</li> <li>• Always Off via App: Off</li> </ul>	Inverter operating normally in grid-tied generation or off-grid mode

Indicator	Indicator Status	Breathing Light Status	Description
		Red flashing	System fault
		Off	Inverter is powered off
		/	Inverter monitoring module resetting
			No connection established between inverter and communication terminal
			Communication fault between communication terminal and cloud server
			Inverter monitoring normal
			Inverter monitoring module not started
			
			Grid normal, inverter BACK-UP port power supply normal
			No power supply to BACK-UP port
			System upgrade
			System fault

Indicator	Indicator Status	Breathing Light Status	Description
			System overload
			Battery has no charge
			Steady on: Charge Flashing: Discharge Battery SOC: 0% < SOC ≤ 25%
			Steady on: Charge Flashing: Discharge Battery SOC: 25% < SOC ≤ 50%
			Steady on: Charge Flashing: Discharge Battery SOC: 50% < SOC ≤ 75%
			Steady on: Charge Flashing: Discharge Battery SOC: 75% < SOC ≤ 100%



## 6.4.2 Battery Indicators



Button Indicators

No.	 Green Light	 Red Light	Battery System Status	Description
1	Steady On	--	System Operating Normally	Run
2	Blinking 1 time/S		System Ready	Standby
	Blinking 3 times/S	--	PCS Communication Lost	--
3	Blinking 1 time/2S	--	System Alarm	Includes Level 2 faults from the fault list, where the under-voltage fault is steady on when it is Level 2, 3, or 4.
4	--	Steady On	System Fault	Level 3 and above faults from the fault list (steady on when under-voltage fault is Level 5).

### 6.4.3 Smart Meter Indicator Lights GM330&GMK330

#### 6.4.3.1 Indicator Light Description

Type	Status	Description
 Power Light	Steady On	The meter is powered on, with no RS485 communication.
	Blinking	The meter is powered on, with normal RS485 communication.
	Off	The meter is powered off.
 Comm Light	Off	Reserved.
	Blinking	Press and hold the Reset button for $\geq 5s$ , and the Power Light and Buy/Sell Power Light blink: The meter is resetting.







Type	Status	Description
 Buy/Sell Power Light	Steady On	buy power from the grid.
	Blinking	Selling power to the grid.
	Off	Not buying or selling power.
 Buy/Sell Power Light (GMK360 only)	Steady On	buy power from the grid.
	Blinking	Selling power to the grid.
	Off	Not buying or selling power.





#### 6.4.4 Smart Dongle Indicator

- WiFi/LAN Kit-20

#### NOTICE

- After double-clicking the Reload button to turn on Bluetooth, the communication indicator light will switch to a single-blink state. Please connect to the App within 5 minutes, otherwise Bluetooth will automatically turn off.
- The communication indicator light's single-blink state only appears after double-clicking the Reload button to turn on Bluetooth.





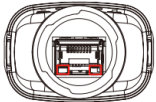



Indicator	Status	Description
Power Light 		Constantly lit: The Smart Communication Stick is powered on.
		Off: The Smart Communication Stick is not powered on.
Communi cation Light 		Constantly lit: Communication is normal in WiFi mode or LAN mode.
		Single flash: The Smart Communication Stick's Bluetooth signal is enabled, waiting to connect to the App.

Indicator	Status	Description
		Two flashes: The Smart Communication Stick is not connected to the router.
		Four flashes: The Smart Communication Stick communicates normally with the router, but is not connected to the server.
		Six flashes: The Smart Communication Stick is identifying connected devices.
		Off: The Smart Communication Stick is undergoing a software reset or is not powered on.

Indicator	Color	Status	Description
LAN port communication light 	Green	Steady on	100Mbps wired network connection is normal.
		Off	<ul style="list-style-type: none"> <li>• Network cable is not connected.</li> <li>• 100Mbps wired network connection is abnormal.</li> <li>• 10Mbps wired network connection is normal.</li> </ul>
	Yellow	Steady on	10/100Mbps wired network connection is normal, with no communication data being transmitted or received.
		Blinking	Communication data is being transmitted or received.
		Off	Network cable is not connected.

Button	Description
Reload	Hold for 0.5~3 seconds, the Smart Communication Stick will reset.
	Hold for 6~20 seconds, the Smart Communication Stick will restore factory settings.
	Double-click quickly to enable Bluetooth signal (maintained for 5 minutes only).

• 4G Kit-G20

Indicator	Status	Description
Power Light 		Steady on: The Smart Communication Stick is powered on.
		Off: The Smart Communication Stick is not powered on.
Communication Light 		Steady on: The Smart Communication Stick is connected to the server, communication is normal.
		Blinks twice: The Smart Communication Stick is not connected to the base station.
		Blinks four times: The Smart Communication Stick is connected to the base station but not to the server.
		Blinks six times: Communication between the Smart Communication Stick and the inverter is disconnected.
		Off: The Smart Communication Stick is undergoing a software reset or is not powered on.
Button	Description	
Reload	Hold for 0.5~3 seconds, the Smart Communication Stick will restart.	
	Hold for 6~20 seconds, the Smart Communication Stick will restore factory settings.	

# 7 System Debugging and Power Station Monitoring

## 7.1 Setting Inverter Parameters via App

SEMS+ App is a software used for remote power plant monitoring or local device debugging. It supports installers or owners to:

- Remotely monitor the operation status of the power plant and set operation parameters for the plant and devices.
- Locally connect to devices to view their operation status and set device parameters.

For detailed functions, please refer to the "[SEMS+ App User Manual](#)". The user manual can be obtained from the official website or by scanning the QR code below.



SEMS+ App User Manual

### 7.1.1 Download and Install SEMS+ App

#### Phone Requirements:

- Operating System: Android 7.0 or above, iOS 15.1 or above.
- Phone must support a web browser and connect to the Internet.
- Phone must support WLAN/Bluetooth functionality.

#### Download Methods:

##### Method 1:

Search for "SEMS+" in Google Play, App Store, Huawei, Honor, Xiaomi, OPPO, or vivo

app stores to download and install.



**Method 2:**

Scan the QR code below to download and install.



## 7.2 Monitoring power stations via SEM+ WEB

SEM+ WEB is a monitoring platform that can communicate via WiFi or LAN. The following are the common functions of SEM+ WEB:

- 1. Manage organization or user information, etc.
- 2. Add and monitor power station information, etc.
- 3. Maintain equipment.

For detailed functions, please refer to the [SEM+ WEB User Manual](#).



SEM+ WEB User Manual

## 8.1 Power OFF the System

### DANGER

- When performing operation and maintenance on equipment in the system, please power off the system. Operating equipment with power on may cause equipment damage or electric shock DANGER.
- After the equipment is powered off, internal components require some time to discharge. Please wait until the equipment is completely discharged according to the label time requirements.
- Restarting the battery should be done using the air switch power-on method.
- When shutting down the battery system, strictly adhere to the battery system power-off requirements to prevent damage to the battery system.

### WARNING

During inverter power-off maintenance or in case of a fault, to ensure normal operation of the load, please switch the manual transfer switch to the grid side to engage, allowing the grid to supply power to the load.

### NOTICE

- To ensure effective protection of the battery system, keep the cover plate of the battery system switch closed. If the battery system switch will not be used for an extended period, secure it with screws.
- PV strings and "5" are only applicable to the ETA series.

### Power off

Single system scenario:

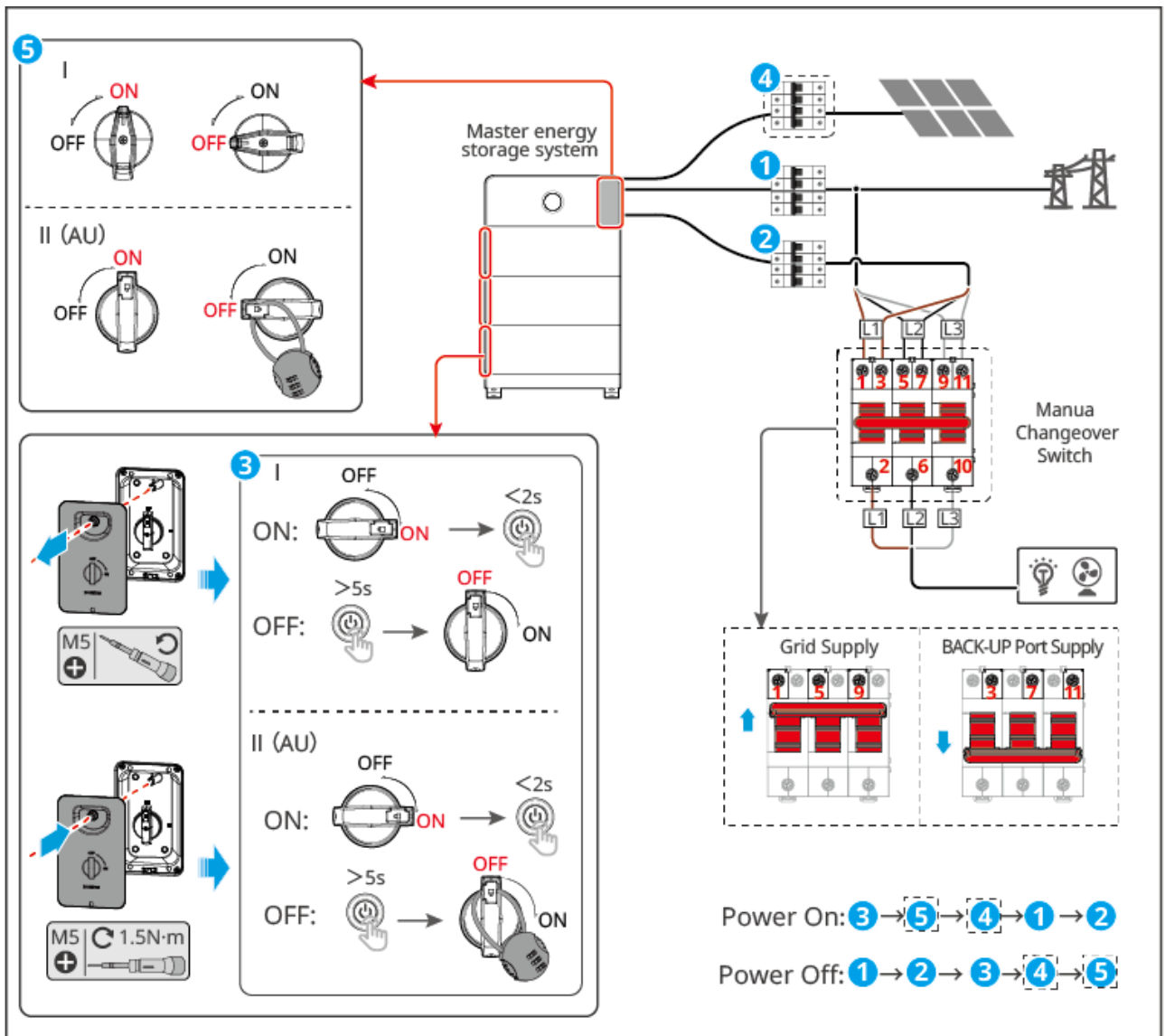

ESA20PWR0003

1. Disconnect the BACK-UP circuit breaker.
2. Disconnect the GRID circuit breaker.
3. Press and hold any battery multi-function button for 5 seconds to power off the battery system. If the system contains multiple batteries, this operation will power off all batteries; there is no need to operate them one by one. Finally, disconnect the battery system switch.
4. (Optional) Disconnect the circuit breaker between the PV components and the inverter.
5. Disconnect the DC switch of the inverter. Set the manual transfer switch to the grid side to engage, allowing the grid to supply power to the loads.

Parallel system:

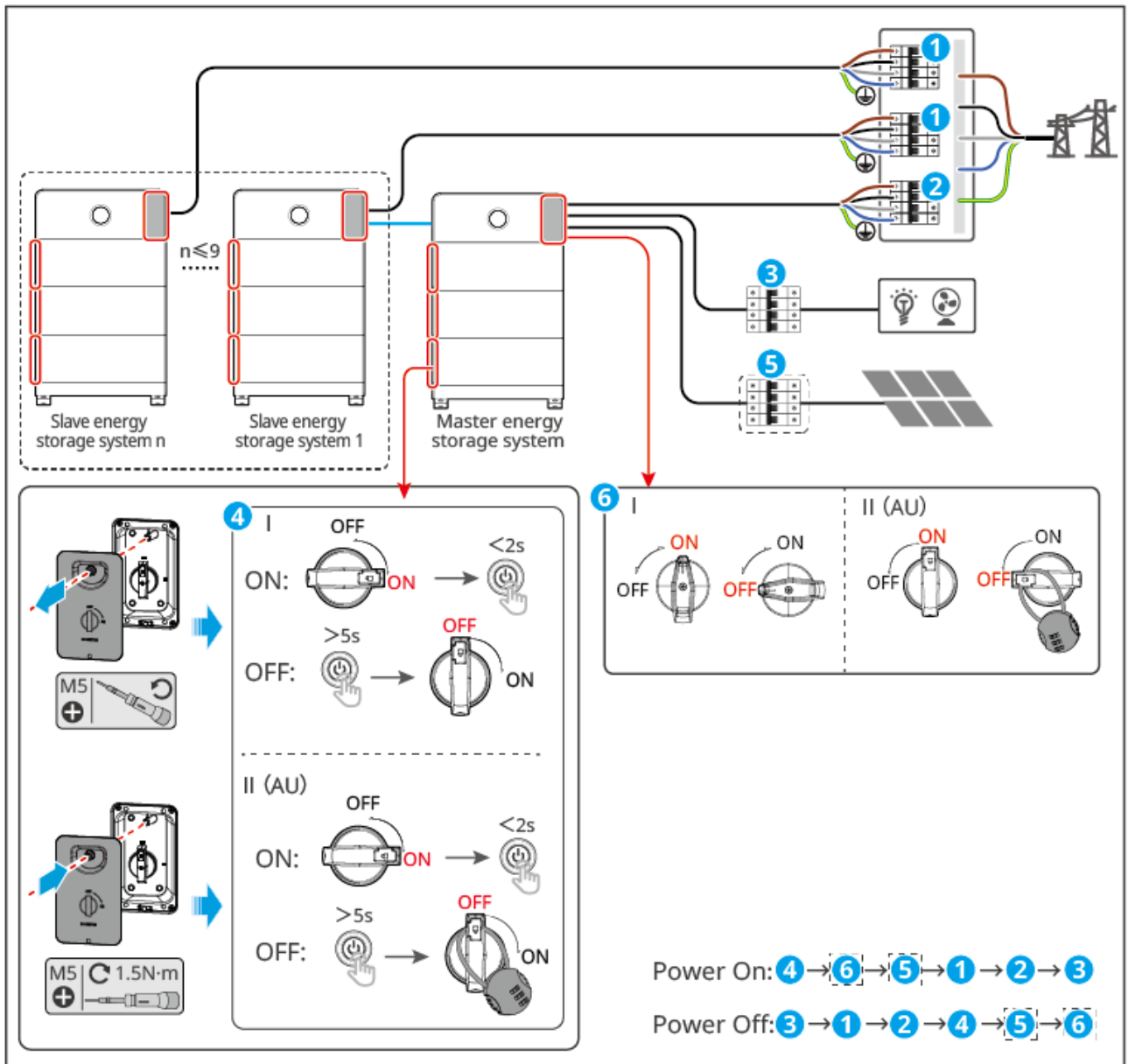

ESA20PWR0005

1. Disconnect the BACK-UP circuit breaker.
2. Disconnect the GRID circuit breaker from the inverter.
3. Disconnect the main inverter GRID circuit breaker.
4. Press and hold any battery multi-function button for 5 seconds to power off the battery system. If the system contains multiple batteries, this operation will power off all batteries; there is no need to operate them one by one. Finally, disconnect the battery system switch.
5. (Optional) Disconnect the circuit breaker between the PV components and the inverter.
6. Disconnect the DC switch of the inverter.

## 8.2 Removing the Equipment



- Ensure the device is powered off.
- When operating the device, please wear personal protective equipment.
- When removing wiring terminals, use standard disassembly tools to avoid damaging the terminals or device.
- Unless otherwise specified, the device disassembly method is the reverse order of the installation method, and this document will not elaborate further.

1. Power down the system.
2. Label the cables connected in the system to indicate their types.
3. Disconnect the cables from the Inverter, Battery, and smart meter in the system, such as DC cables, AC cables, Communication cable, and PE cable.
4. Remove equipment such as the smart communication stick, Inverter, Battery, and smart meter.
5. Store the equipment properly. If it will be put into use again later, ensure the storage conditions meet the requirements.

## 8.3 Disposing of the Equipment

When the equipment can no longer be used and needs to be disposed of, please handle it according to the electrical waste disposal requirements of the regulations in the country/region where the equipment is located. The equipment must not be disposed of as general household waste.

## 8.4 Routine Maintenance



- If any issues that may affect the Battery or hybrid inverter system are discovered, please contact after-sales personnel. Unauthorized disassembly is strictly prohibited.
- If exposed copper wires are found inside the conductive line, do not touch them. High voltage DANGER, please contact after-sales personnel. Unauthorized disassembly is prohibited.
- In case of any other emergencies, please contact the after-sales personnel immediately. Follow their instructions for operation or wait for on-site assistance from the after-sales team.

Maintenance Content	Maintenance method	Maintenance cycle	Maintenance purpose
System cleaning	<p>Check for any foreign objects or dust in the heat sink and air inlet/outlet.</p> <p>Check if the Installation space meets the requirements, and inspect whether there is any debris accumulation around the equipment.</p>	Once every six months	Prevent heat dissipation.
System Installation	<p>Check whether the equipment Installation is secure and whether the fasteners screw are loose.</p> <p>Inspect the equipment for any damage or deformation on the exterior.</p>	Once every six months to once a year	Verify the stability of the Installation equipment.
Electrical connection	Check for loose electrical connections, damaged cable insulation, or exposed copper conductors.	Once every six months to once a year	Verify the reliability of electrical connections.

Maintenance Content	Maintenance method	Maintenance cycle	Maintenance purpose
fan	Check if the fan has any abnormal noise; Check the fan blades for cracks; Check if the fan has abnormal blockage or stalling;	1 time/half year	Prevent fan fault.
Sealing	Check whether the cable entry hole Sealing of the equipment meets the requirements. If the gap is too large or unsealed, resealing is required.	Once per year	Verify that the machine's sealing and waterproof performance are intact.
Battery maintenance	If the Battery has not been used or fully charged for a long time, it is recommended to perform Charge on the Battery regularly.	Once/15 days	Protection Battery service life.

Fan maintenance can be specifically referred to the following steps:

There is a fan module on the exterior of Inverter. To clean the fan module more effectively, remove it from the machine before cleaning. The specific steps are as follows:

1. Inverter power off, refer to [8.1. Power OFF the System \(Page 147\)](#).
2. Wait for the residual voltage in the system to be fully discharged and the fan module to completely stop operating.
3. Use screwdriver dismantle module to lock screw, and remove the entire fan module.
4. Clean the fan using a soft brush, cloth, or vacuum cleaner.

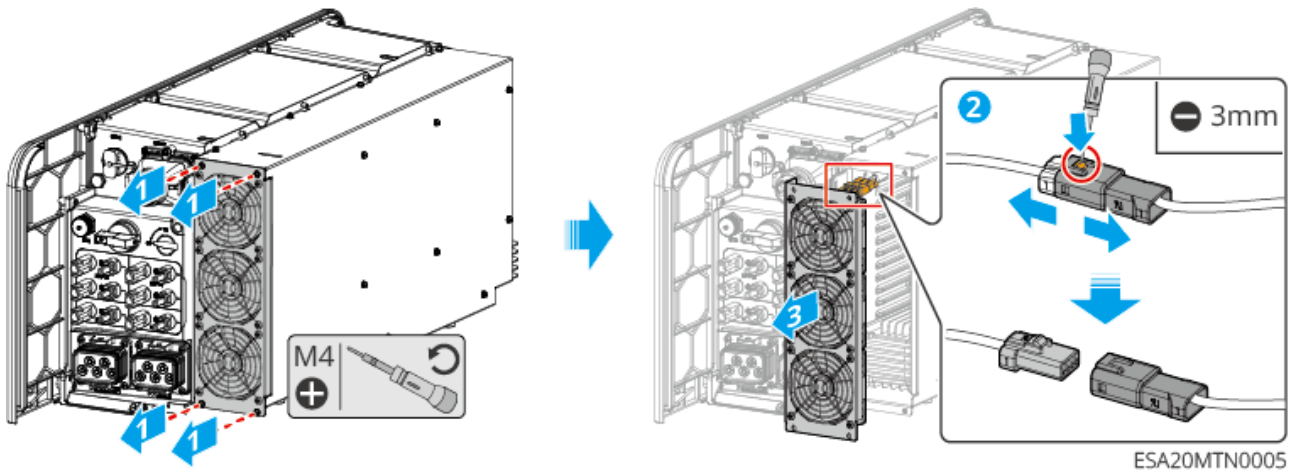

After cleaning, reinstall the fan module back into the machine.

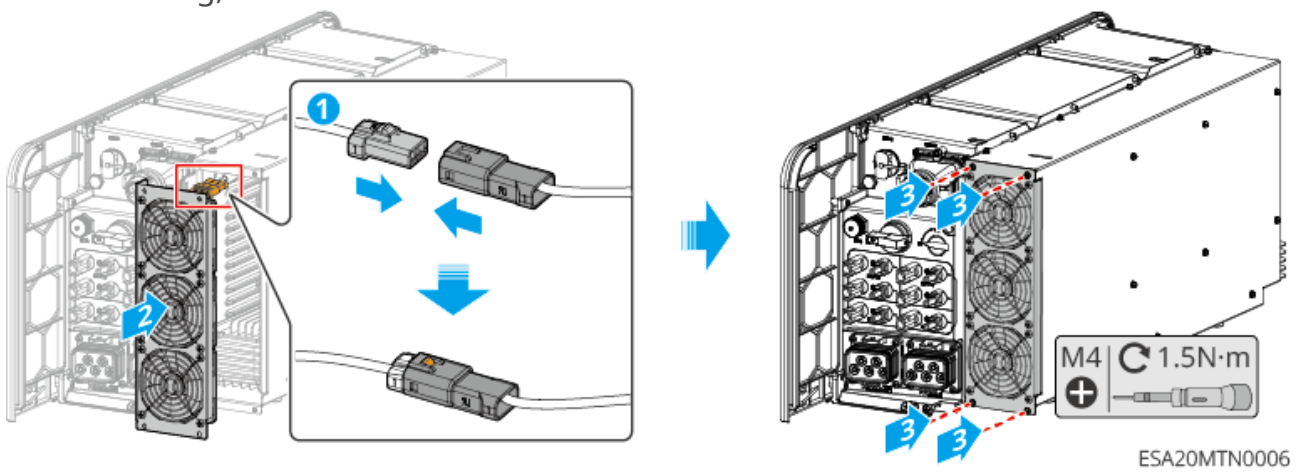

## 8.5 fault

### NOTICE

The manual's fault content is updated irregularly, and there may be slight variations between different models. Please refer to the real-time display on your device for specific information.

### 8.5.1 Viewing Fault/Alarms Information

Detailed information for all faults and alarms in the energy storage system is displayed in the **SEMS+ App and SEMS+ WEB**. If your product experiences an abnormality and no related fault information is seen in the **SEMS+ App or SEMS+ WEB**, please contact the after-sales service center.

- In SEMS+ App

1. Open the SEMS+ App and log in with any account.
2. On the homepage, click "Alarms" to view alarm information for all power plants under the account.

- SEMS+ WEB

1. Open the SEMS+ WEB and log in with any account.
2. On the power plant details interface, click "Alarms" to view all alarm information for the current power plant.

## **8.5.2 Fault Information and Troubleshooting**

Please perform troubleshooting according to the following methods. If the troubleshooting methods cannot help you, please contact the after-sales service center.

When contacting the after-sales service center, please collect the following information to facilitate a quick resolution.

1. Product information, such as: serial number, software version, device installation time, fault occurrence time, fault frequency, etc.
2. Device installation environment, such as: weather conditions, whether components are blocked, have shadows, etc. It is recommended to provide photos, videos, and other files to assist in problem analysis.
3. Grid conditions.

If the system experiences a problem not listed, or if following the instructions still cannot prevent the problem or abnormality, immediately stop system operation and contact your dealer immediately.

No.	fault	Resolution
1	Unable to search for the Smart Communication Stick's wireless signal	<ol style="list-style-type: none"> <li>1. Ensure no other devices are connected to the Smart Communication Stick's wireless signal.</li> <li>2. Ensure the Smart Communication Stick is powered normally, with the blue signal light flashing or steady on.</li> <li>3. Ensure the smart device is within the communication range of the Smart Communication Stick.</li> <li>4. Refresh the App device list again.</li> <li>5. Restart the inverter.</li> </ol>
2	Unable to connect to the Smart Communication Stick's wireless signal	<ol style="list-style-type: none"> <li>1. Ensure no other devices are connected to the Smart Communication Stick's wireless signal.</li> <li>2. Restart the inverter or the communication stick, then try connecting to the Smart Communication Stick's wireless signal again.</li> <li>3. Ensure Bluetooth pairing and encryption were successful.</li> </ol>
3	Unable to find the router's SSID	<ol style="list-style-type: none"> <li>1. Place the router closer to the Smart Communication Stick, or add a WiFi repeater to enhance the WiFi signal.</li> <li>2. Reduce the number of devices connected to the router.</li> </ol>
4	After all configuration is complete, the Smart Communication Stick fails to connect to the router	<ol style="list-style-type: none"> <li>1. Restart the inverter.</li> <li>2. Check if the network name, encryption method, and password in the WiFi configuration match those of the router.</li> <li>3. Restart the router.</li> <li>4. Place the router closer to the Smart Communication Stick, or add a WiFi repeater to enhance the WiFi signal.</li> </ol>

No.	fault	Resolution
5	After all configuration is complete, the Smart Communication Stick fails to connect to the server	Restart the router and the inverter.

### 8.5.2.1 Inverter Fault

#### 8.5.2.1.1 Troubleshooting (Fault Codes F01-F40)

Fault Code	Fault Name	Fault Cause	Troubleshooting Suggestion
F01	Grid Power Outage	<ol style="list-style-type: none"> <li>1. Grid power outage.</li> <li>2. AC line or AC switch is disconnected.</li> </ol>	<ol style="list-style-type: none"> <li>1. The alarm will disappear automatically after grid power supply recovers.</li> <li>2. Check if the AC line or AC switch is disconnected.</li> </ol>

Fault Code	Fault Name	Fault Cause	Troubleshooting Suggestion
F02	Grid Overvoltage Protection	Grid voltage is higher than the allowable range, or the duration of high voltage exceeds the high voltage ride-through setting.	<ol style="list-style-type: none"> <li>1. If it occurs occasionally, it may be a short-term grid anomaly. The inverter will resume normal operation after detecting the grid is normal, requiring no manual intervention.</li> <li>2. If it occurs frequently, check if the grid voltage is within the allowable range. If not, contact the local power operator. If yes, also modify the grid overvoltage protection point after obtaining consent from the local power operator.</li> <li>3. If it cannot recover for a long time, check if the AC side circuit breaker and output cable are properly connected.</li> </ol>

Fault Code	Fault Name	Fault Cause	Troubleshooting Suggestion
F03	Grid Undervoltage Protection	Grid voltage is lower than the allowable range, or the duration of low voltage exceeds the low voltage ride-through setting.	<ol style="list-style-type: none"> <li>1. If it occurs occasionally, it may be a short-term grid anomaly. The inverter will resume normal operation after detecting the grid is normal, requiring no manual intervention.</li> <li>2. If it occurs frequently, check if the grid voltage is within the allowable range. If not, contact the local power operator. If yes, also modify the grid undervoltage protection point after obtaining consent from the local power operator.</li> <li>3. If it cannot recover for a long time, check if the AC side circuit breaker and output cable are properly connected.</li> </ol>

Fault Code	Fault Name	Fault Cause	Troubleshooting Suggestion
F04	Grid Rapid Overvoltage Protection	Abnormal grid voltage detection or ultra-high voltage triggers the fault.	<p>1. If it occurs occasionally, it may be a short-term grid anomaly. The inverter will resume normal operation after detecting the grid is normal, requiring no manual intervention.</p> <p>2. If it occurs frequently, check if the grid voltage is within the allowable range. If not, contact the local power operator. If yes, also modify the grid undervoltage protection point after obtaining consent from the local power operator.</p> <p>3. If it cannot recover for a long time, check if the AC side circuit breaker and output cable are properly connected.</p>
F05	10min Overvoltage Protection	The moving average of grid voltage within 10min exceeds the safety regulation range.	Check if the grid voltage is operating at a high voltage for a long period. If it occurs frequently, check if the grid frequency is within the allowable range. If not, contact the local power operator. If yes, also modify the grid 10min overvoltage protection point after obtaining consent from the local power operator.

Fault Code	Fault Name	Fault Cause	Troubleshooting Suggestion
F06	Grid Overfrequency	Grid anomaly: The actual grid frequency is higher than the local grid standard requirements.	<p>1. If it occurs occasionally, it may be a short-term grid anomaly. The inverter will resume normal operation after detecting the grid is normal, requiring no manual intervention.</p> <p>2. If it occurs frequently, check if the grid frequency is within the allowable range. If not, contact the local power operator. If yes, also modify the grid overfrequency protection point after obtaining consent from the local power operator.</p>
F07	Grid Underfrequency	Grid anomaly: The actual grid frequency is lower than the local grid standard requirements.	<p>1. If it occurs occasionally, it may be a short-term grid anomaly. The inverter will resume normal operation after detecting the grid is normal, requiring no manual intervention.</p> <p>2. If it occurs frequently, check if the grid frequency is within the allowable range. If not, contact the local power operator. If yes, also modify the grid overfrequency protection point after obtaining consent from the local power operator.</p>

Fault Code	Fault Name	Fault Cause	Troubleshooting Suggestion
F08	Grid Frequency Instability	Grid anomaly: The rate of change of the actual grid frequency does not comply with the local grid standard.	<p>1. If it occurs occasionally, it may be a short-term grid anomaly. The inverter will resume normal operation after detecting the grid is normal, requiring no manual intervention.</p> <p>2. If it occurs frequently, check if the grid frequency is within the allowable range. If not, contact the local power operator.</p>
F09	Anti-islanding Protection	The grid has been disconnected. The grid voltage is maintained due to the presence of loads, and grid connection is stopped according to safety protection requirements.	<p>1. If it occurs occasionally, it may be a short-term grid anomaly. The inverter will resume normal operation after detecting the grid is normal, requiring no manual intervention.</p> <p>2. If it occurs frequently, check if the grid frequency is within the allowable range. If not, contact the local power operator.</p>
F10	LVRT Undervoltage Fault	Grid anomaly: The duration of abnormal grid voltage exceeds the time specified for high/low voltage ride-through.	<p>1. If it occurs occasionally, it may be a short-term grid anomaly. The inverter will resume normal operation after detecting the grid is normal, requiring no manual intervention.</p> <p>2. If it occurs frequently, check if the grid voltage and frequency are within the allowable range and stable. If not, contact the local power operator.</p>

Fault Code	Fault Name	Fault Cause	Troubleshooting Suggestion
F11	HVRT Overvoltage	Grid anomaly: The duration of abnormal grid voltage exceeds the time specified for high/low voltage ride-through.	<p>1. If it occurs occasionally, it may be a short-term grid anomaly. The inverter will resume normal operation after detecting the grid is normal, requiring no manual intervention.</p> <p>2. If it occurs frequently, check if the grid voltage and frequency are within the allowable range and stable. If not, contact the local power operator.</p>
F12	30mA GFCI Protection	The input-to-ground insulation impedance becomes low during inverter operation.	<p>1. If it occurs occasionally, it may be caused by a temporary external line anomaly. The inverter will resume normal operation after the fault is cleared, requiring no manual intervention.</p> <p>2. If it occurs frequently or cannot recover for a long time, check if the PV string-to-ground impedance is too low.</p>
F13	60mA GFCI Protection	The input-to-ground insulation impedance becomes low during inverter operation.	<p>1. If it occurs occasionally, it may be caused by a temporary external line anomaly. The inverter will resume normal operation after the fault is cleared, requiring no manual intervention.</p> <p>2. If it occurs frequently or cannot recover for a long time, check if the PV string-to-ground impedance is too low.</p>

Fault Code	Fault Name	Fault Cause	Troubleshooting Suggestion
F14	150mA GFCI Protection	The input-to-ground insulation impedance becomes low during inverter operation.	<p>1. If it occurs occasionally, it may be caused by a temporary external line anomaly. The inverter will resume normal operation after the fault is cleared, requiring no manual intervention.</p> <p>2. If it occurs frequently or cannot recover for a long time, check if the PV string-to-ground impedance is too low.</p>
F15	GFCI Gradual Change Protection	The input-to-ground insulation impedance becomes low during inverter operation.	<p>1. If it occurs occasionally, it may be caused by a temporary external line anomaly. The inverter will resume normal operation after the fault is cleared, requiring no manual intervention.</p> <p>2. If it occurs frequently or cannot recover for a long time, check if the PV string-to-ground impedance is too low.</p>
F16	DCI Level 1 Protection	The DC component of the inverter output current is higher than the safety regulation or the machine's default allowable range.	<p>1. If it is caused by an external fault anomaly, the inverter will automatically resume normal operation after the fault disappears, requiring no manual intervention.</p> <p>2. If this alarm occurs frequently, affecting the normal power generation of the power station, contact the dealer or after-sales service center.</p>

Fault Code	Fault Name	Fault Cause	Troubleshooting Suggestion
F17	DCI Level 2 Protection	The DC component of the inverter output current is higher than the safety regulation or the machine's default allowable range.	<ol style="list-style-type: none"> <li>1. If it is caused by an external fault anomaly, the inverter will automatically resume normal operation after the fault disappears, requiring no manual intervention.</li> <li>2. If this alarm occurs frequently, affecting the normal power generation of the power station, contact the dealer or after-sales service center.</li> </ol>

Fault Code	Fault Name	Fault Cause	Troubleshooting Suggestion
F18	Low Insulation Resistance	<ol style="list-style-type: none"> <li>1. PV string is short-circuited to protective earth.</li> <li>2. The PV string is installed in a long-term humid environment with poor line-to-ground insulation.</li> <li>3. Low insulation resistance of the battery port line to ground.</li> </ol>	<ol style="list-style-type: none"> <li>1. Check the impedance of the PV string/battery port to protective earth. A value greater than 80kΩ is normal. If the measured value is less than 80kΩ, locate and rectify the short-circuit point.</li> <li>2. Check if the inverter's protective earth wire is correctly connected.</li> <li>3. If it is confirmed that the impedance is indeed lower than the default value in rainy weather conditions, please reset the inverter's "Insulation Resistance Protection Point" via the App.</li> </ol> <p>For inverters in the Australian and New Zealand markets, when an insulation resistance fault occurs, the alarm can also be indicated by the following methods:</p> <ol style="list-style-type: none"> <li>1. The inverter is equipped with a buzzer. When a fault occurs, the buzzer sounds continuously for 1 minute; if the fault is not resolved, the buzzer sounds again every 30 minutes.</li> <li>2. If the inverter is added to the monitoring platform and the alarm notification method is set, the alarm information can be sent to the customer via email.</li> </ol>

Fault Code	Fault Name	Fault Cause	Troubleshooting Suggestion
F19	Grounding Abnormal	<ol style="list-style-type: none"> <li>1. The inverter's protective earth wire is not connected.</li> <li>2. When the PV string output is grounded, the inverter output side is not connected to an isolation transformer.</li> </ol>	<ol style="list-style-type: none"> <li>1. Please confirm if the inverter's protective earth wire is not properly connected.</li> <li>2. In scenarios where the PV string output is grounded, please confirm if the inverter output side is connected to an isolation transformer.</li> </ol>
F20	Hardware Anti-reverse Flow Protection	Abnormal load fluctuation	<ol style="list-style-type: none"> <li>1. If it is caused by an external fault anomaly, the inverter will automatically resume normal operation after the fault disappears, requiring no manual intervention.</li> <li>2. If this alarm occurs frequently, affecting the normal power generation of the power station, contact the dealer or after-sales service center.</li> </ol>

Fault Code	Fault Name	Fault Cause	Troubleshooting Suggestion
F21	Internal Comm Loss	Slave DSP1 communication timeout - Master DSP, Slave DSP2 communication timeout - Master DSP, Slave DSP2 communication timeout - Slave DSP1, Master DSP communication timeout - Slave DSP1, Master DSP communication timeout - Slave DSP2, or Slave DSP1 communication timeout - Slave DSP2: 1. Chip not powered on 2. Incorrect chip firmware version	Disconnect the AC output side switch and DC input side switch, wait for 5 minutes, then close the AC output side switch and DC input side switch. If the fault persists, contact the dealer or after-sales service center.

Fault Code	Fault Name	Fault Cause	Troubleshooting Suggestion
		Master DSP CAN module error, Slave DSP1 CAN module error, or Slave DSP2 CAN module error: 1. Frame format error 2. Parity check error 3. CAN bus offline 4. Hardware CRC check error 5. Control bit is receive (transmit) during transmission (reception) 6. Transmission to a disallowed unit	
F22	Generator Waveform Detection Fault	1. This fault will be displayed continuously when a generator is not connected; 2. When the generator is operating, failure to meet generator safety regulations will trigger this fault.	1. Ignore this fault if no generator is connected; 2. When this fault appears due to a generator fault, it is normal. After the generator recovers, wait for a period of time, and the fault will be cleared automatically; 3. This fault does not affect the normal operation of the off-grid mode. 4. When both the generator and the grid are connected and meet safety requirements, the grid has priority for grid connection, and the system will operate in grid-connected state.
F23	Generator Abnormal Connection		
F24	Generator Voltage Low		
F25	Generator Voltage High		
F26	Generator Frequency Low		

<b>Fault Code</b>	<b>Fault Name</b>	<b>Fault Cause</b>	<b>Troubleshooting Suggestion</b>
F27	Generator Frequency High		
F28	Parallel Unit I/O Self-check Abnormal	Parallel communication cable is not securely connected or parallel IO chip is damaged	Check if the parallel communication cable is securely connected, then check if the IO chip is damaged. If yes, replace the IO chip.
F29	Paralell Grid Line Reversed	Some units' grid lines are reversed with others	Reconnect the grid lines.
F30	AC HCT check Abnormal	AC sensor has sampling abnormality	Disconnect the AC output side switch and DC input side switch, wait for 5 minutes, then close the AC output side switch and DC input side switch. If the fault persists, contact the dealer or after-sales service center.
F31	GFCI HCT Check Abnormal	Leakage current sensor has sampling abnormality	Disconnect the AC output side switch and DC input side switch, wait for 5 minutes, then close the AC output side switch and DC input side switch. If the fault persists, contact the dealer or after-sales service center.
F32	Inverter Internal Failure	Inverter has a fault	Disconnect the AC output side switch and DC input side switch, wait for 5 minutes, then close the AC output side switch and DC input side switch. If the fault persists, contact the dealer or after-sales service center.
F33	Flash Read/Write Error	Possible causes: Flash content changed; Flash lifespan exhausted;	1. Upgrade to the latest firmware version. 2. Contact the dealer or after-sales service center.

Fault Code	Fault Name	Fault Cause	Troubleshooting Suggestion
F34	AFCI Check Failure	During the arc fault self-check process, the arc fault module did not detect an arc fault as expected.	Disconnect the AC output side switch and DC input side switch, wait for 5 minutes, then close the AC output side switch and DC input side switch. If the fault persists, contact the dealer or after-sales service center.
F35	Cabinet Overtemperature	Cabinet temperature is too high. Possible causes: 1. Inverter installation location is not ventilated. 2. Ambient temperature is too high. 3. Internal fan operation is abnormal.	1. Check if the ventilation at the inverter installation location is good and if the ambient temperature exceeds the maximum allowable ambient temperature range. 2. If it is not ventilated or the ambient temperature is too high, improve its ventilation and heat dissipation conditions. 3. If ventilation and ambient temperature are normal, contact the dealer or after-sales service center.

Fault Code	Fault Name	Fault Cause	Troubleshooting Suggestion
F36	Bus Overvoltage	BUS overvoltage, possible causes: 1. PV voltage is too high; 2. Inverter BUS voltage sampling is abnormal; 3. The isolation effect of the dual-split transformer at the inverter's rear end is poor, causing two inverters to affect each other when connected in parallel, with one inverter reporting DC overvoltage when grid-connected;	Disconnect the AC output side switch and DC input side switch, wait for 5 minutes, then close the AC output side switch and DC input side switch. If the fault persists, contact the dealer or after-sales service center.

Fault Code	Fault Name	Fault Cause	Troubleshooting Suggestion
F37	PV Input Overvoltage	<p>PV input voltage is too high, possible cause:            Incorrect photovoltaic array configuration, too many PV panels connected in series in a string, resulting in the string's open-circuit voltage being higher than the inverter's maximum operating voltage.</p>	<p>Check the series configuration of the corresponding PV array string to ensure the string's open-circuit voltage does not exceed the inverter's maximum operating voltage. After the PV array configuration is corrected, the inverter alarm will disappear automatically.</p>
F38	PV Persistent Hardware Overcurrent	<ol style="list-style-type: none"> <li>1. Unreasonable module configuration.</li> <li>2. Hardware damage.</li> </ol>	<p>Disconnect the AC output side switch and DC input side switch, wait for 5 minutes, then close the AC output side switch and DC input side switch. If the fault persists, contact the dealer or after-sales service center.</p>
F39	PV Persistent Software Overcurrent	<ol style="list-style-type: none"> <li>1. Unreasonable module configuration.</li> <li>2. Hardware damage.</li> </ol>	<p>Disconnect the AC output side switch and DC input side switch, wait for 5 minutes, then close the AC output side switch and DC input side switch. If the fault persists, contact the dealer or after-sales service center.</p>

<b>Fault Code</b>	<b>Fault Name</b>	<b>Fault Cause</b>	<b>Troubleshooting Suggestion</b>
F40, F98	String Reversed Connection (String 1-n) n: Determined based on the actual number of inverter strings.	PV string reversed connection	Check if the string is reversed.

#### 8.5.2.1.2 Troubleshooting (Fault Codes F41-F80)

<b>Fault Code</b>	<b>Fault Name</b>	<b>Fault Cause</b>	<b>Fault Handling Suggestion</b>
F41	Generator Port Overload	<ol style="list-style-type: none"> <li>1. Off-grid output exceeds specifications.</li> <li>2. Short circuit on the off-grid side.</li> <li>3. Off-grid terminal voltage is too low.</li> <li>4. When used as a large load port, the large load exceeds specifications.</li> </ol>	Confirm the off-grid output voltage, current, power, and other data to identify the cause of the issue.

<b>Fault Code</b>	<b>Fault Name</b>	<b>Fault Cause</b>	<b>Fault Handling Suggestion</b>
F42	DC Arcing Failure (String 1-n) n: Determined based on the actual number of inverter strings.	<ol style="list-style-type: none"> <li>1. Loose DC side connection terminals.</li> <li>2. Poor connection at DC side terminals.</li> <li>3. Damaged DC cable cores causing poor connection.</li> </ol>	<ol style="list-style-type: none"> <li>1. After the machine reconnects to the grid, check if the voltage and current of each string abnormally decrease or become zero.</li> <li>2. Check if the DC side terminals are securely connected.</li> </ol>
F43	Grid Waveform Abnormal	Utility grid abnormality: Abnormal utility grid voltage detection triggers the fault.	<ol style="list-style-type: none"> <li>1. If it occurs occasionally, it may be due to a short-term utility grid abnormality. The inverter will resume normal operation after detecting normal utility grid conditions, requiring no manual intervention.</li> <li>2. If it occurs frequently, please check if the utility grid voltage and frequency are within the allowable range and stable. If not, please contact the local power operator.</li> </ol>
F44	Grid Phase Loss	Utility grid abnormality: Single-phase voltage dip in the utility grid.	<ol style="list-style-type: none"> <li>1. If it occurs occasionally, it may be due to a short-term utility grid abnormality. The inverter will resume normal operation after detecting normal utility grid conditions, requiring no manual intervention.</li> <li>2. If it occurs frequently, please check if the utility grid voltage and frequency are within the allowable range and stable. If not, please contact the local power operator.</li> </ol>

<b>Fault Code</b>	<b>Fault Name</b>	<b>Fault Cause</b>	<b>Fault Handling Suggestion</b>
F45	Grid Voltage Imbalance	Excessive difference in utility grid phase voltages.	<ol style="list-style-type: none"> <li>1. If it occurs occasionally, it may be due to a short-term utility grid abnormality. The inverter will resume normal operation after detecting normal utility grid conditions, requiring no manual intervention.</li> <li>2. If it occurs frequently, please check if the utility grid voltage and frequency are within the allowable range and stable. If not, please contact the local power operator.</li> </ol>
F46	Grid Phase Sequence Failure	Inverter-to-grid wiring abnormality: Wiring is not in positive sequence.	<ol style="list-style-type: none"> <li>1. Check if the inverter-to-grid wiring is in positive sequence. The fault will automatically disappear after correct wiring (e.g., swapping any two live wires).</li> <li>2. If the fault persists despite correct wiring, please contact the dealer or after-sales service center.</li> </ol>
F47	Grid Rapid Shutdown Protection	Quickly shuts down output after detecting a utility grid power outage condition.	The fault automatically disappears after utility grid power supply is restored.
F48	Grid Neutral Wire Loss (Split grid)	Neutral wire loss in a split-phase grid.	<ol style="list-style-type: none"> <li>1. The alarm automatically disappears after the utility grid power supply is restored.</li> <li>2. Check if the AC circuit or AC switch is disconnected.</li> </ol>
F49	L-PE Short Circuit	Low impedance or short circuit between output phase line and PE.	Measure the impedance between the output phase line and PE, locate the position with low impedance and repair it.

<b>Fault Code</b>	<b>Fault Name</b>	<b>Fault Cause</b>	<b>Fault Handling Suggestion</b>
F50	DCV Level 1 Protection	Abnormal load fluctuation.	<p>1. If it is caused by an external fault, the inverter will automatically resume normal operation after the fault disappears, requiring no manual intervention.</p> <p>2. If this alarm occurs frequently, affecting normal power generation of the plant, please contact the dealer or after-sales service center.</p>
F51	DCV Level 2 Protection	Abnormal load fluctuation.	
F52	Leakage current (GFCI) Multiple Fault Shutdown	North American safety regulations require manual recovery or waiting 24h after multiple faults, no automatic recovery.	Please check if the PV string-to-ground impedance is too low.
F53	DC Arcing (AFCI) Multiple Fault Shutdown	North American safety regulations require manual recovery or waiting 24h after multiple faults, no automatic recovery.	<p>1. After the machine reconnects to the grid, check if the voltage and current of each string abnormally decrease or become zero.</p> <p>2. Check if the DC side terminals are securely connected.</p>
F54	External Communication Link Break	Inverter external device communication lost, possibly due to peripheral power supply issue, communication protocol mismatch, or not configured for the corresponding peripheral.	Determine based on the actual model and detection enable bits. Peripherals not supported by some models will not be detected.

<b>Fault Code</b>	<b>Fault Name</b>	<b>Fault Cause</b>	<b>Fault Handling Suggestion</b>
F55	Back-up Port Overload Fault	Prevents the inverter from continuous overload output.	Turn off some off-grid loads to reduce the inverter's off-grid output power.
F56	Back-up Port Overvoltage Fault	Prevents inverter output overvoltage from damaging loads.	1. If it occurs occasionally, it may be caused by load switching and requires no manual intervention. 2. If it occurs frequently, please contact the dealer or after-sales service center.
F57	External Box Fault	Waiting for Box relay switching time is too long during grid-to-off-grid transition.	1. Check if the Box is working normally. 2. Check if the Box communication wiring is correct.
F58	CT Loss Fault	CT connection wire disconnected (Japanese safety regulation requirement).	Check if the CT wiring is correct.
F59	Parallel CAN Communication Abnormal	Parallel communication cable not securely connected or some machines are offline.	Check if all machines are powered on and if the parallel communication cables are securely connected.
F60	Parallel Back-up Connection Reversed	Some machines' backup lines are reversed with others.	Reconnect the backup lines.
F61	Inverter Soft Start Failure	Inverter soft start failure during off-grid cold start.	Check if the inverter module is damaged.

<b>Fault Code</b>	<b>Fault Name</b>	<b>Fault Cause</b>	<b>Fault Handling Suggestion</b>
F62	AC HCT Failure	HCT sensor is abnormal.	Turn off the AC output side switch and DC input side switch, wait for 5 minutes, then turn on the AC output side switch and DC input side switch. If the fault persists, please contact the dealer or after-sales service center.
F63	GFCI HCT Failure	Leakage current sensor is abnormal.	Turn off the AC output side switch and DC input side switch, wait for 5 minutes, then turn on the AC output side switch and DC input side switch. If the fault persists, please contact the dealer or after-sales service center.
F64	Inverter Internal Failure	Inverter has a fault.	Turn off the AC output side switch and DC input side switch, wait for 5 minutes, then turn on the AC output side switch and DC input side switch. If the fault persists, please contact the dealer or after-sales service center.
F65	AC Terminal Overtemperature	AC terminal temperature is too high. Possible causes: 1. Inverter installation location is not ventilated. 2. Ambient temperature is too high. 3. Internal fan operation is abnormal.	1. Check if the ventilation at the inverter installation location is good and if the ambient temperature exceeds the maximum allowable range. 2. If ventilation is poor or ambient temperature is too high, improve ventilation and heat dissipation conditions. 3. If ventilation and ambient temperature are normal, please contact the dealer or after-sales service center.

Fault Code	Fault Name	Fault Cause	Fault Handling Suggestion
F66	INV Module Overtemperature	Inverter module temperature is too high. Possible causes: 1. Inverter installation location is not ventilated. 2. Ambient temperature is too high. 3. Internal fan operation is abnormal.	1. Check if the ventilation at the inverter installation location is good and if the ambient temperature exceeds the maximum allowable range. 2. If ventilation is poor or ambient temperature is too high, improve ventilation and heat dissipation conditions. 3. If ventilation and ambient temperature are normal, please contact the dealer or after-sales service center.
F67	Boost Module Overtemperature	Boost module temperature is too high. Possible causes: 1. Inverter installation location is not ventilated. 2. Ambient temperature is too high. 3. Internal fan operation is abnormal.	1. Check if the ventilation at the inverter installation location is good and if the ambient temperature exceeds the maximum allowable range. 2. If ventilation is poor or ambient temperature is too high, improve ventilation and heat dissipation conditions. 3. If ventilation and ambient temperature are normal, please contact the dealer or after-sales service center.

<b>Fault Code</b>	<b>Fault Name</b>	<b>Fault Cause</b>	<b>Fault Handling Suggestion</b>
F68	AC Capacitor Overtemperature	Output filter capacitor temperature is too high. Possible causes: 1. Inverter installation location is not ventilated. 2. Ambient temperature is too high. 3. Internal fan operation is abnormal.	1. Check if the ventilation at the inverter installation location is good and if the ambient temperature exceeds the maximum allowable range. 2. If ventilation is poor or ambient temperature is too high, improve ventilation and heat dissipation conditions. 3. If ventilation and ambient temperature are normal, please contact the dealer or after-sales service center.
F69	PV IGBT Short Circuit Fault	Possible causes: 1. IGBT short circuit. 2. Inverter sampling circuit abnormality.	Turn off the AC output side switch and DC input side switch, wait for 5 minutes, then turn on the AC output side switch and DC input side switch. If the fault persists, please contact the dealer or after-sales service center.
F70	PV IGBT Open Circuit Fault	1. Software issue causing no PWM generation. 2. Drive circuit abnormality. 3. IGBT open circuit.	
F71	NTC Abnormal	NTC temperature sensor is abnormal.	Turn off the AC output side switch and DC input side switch, wait for 5 minutes, then turn on the AC output side switch and DC input side switch. If the fault persists, please contact the dealer or after-sales service center.

<b>Fault Code</b>	<b>Fault Name</b>	<b>Fault Cause</b>	<b>Fault Handling Suggestion</b>
F72	PWM Abnormal	PWM abnormal waveform detected.	Turn off the AC output side switch and DC input side switch, wait for 5 minutes, then turn on the AC output side switch and DC input side switch. If the fault persists, please contact the dealer or after-sales service center.
F73	CPU Interrupt Abnormal	CPU interrupt is abnormal.	Turn off the AC output side switch and DC input side switch, wait for 5 minutes, then turn on the AC output side switch and DC input side switch. If the fault persists, please contact the dealer or after-sales service center.
F74	Microelectronics Fault	Functional safety detected an abnormality.	Turn off the AC output side switch and DC input side switch, wait for 5 minutes, then turn on the AC output side switch and DC input side switch. If the fault persists, please contact the dealer or after-sales service center.
F75	PV HCT Fault	Boost current sensor is abnormal.	Turn off the AC output side switch and DC input side switch, wait for 5 minutes, then turn on the AC output side switch and DC input side switch. If the fault persists, please contact the dealer or after-sales service center.
F76	1.5V Reference Abnormal	Reference circuit fault.	Turn off the AC output side switch and DC input side switch, wait for 5 minutes, then turn on the AC output side switch and DC input side switch. If the fault persists, please contact the dealer or after-sales service center.
F77	0.3V Reference Abnormal	Reference circuit fault.	

<b>Fault Code</b>	<b>Fault Name</b>	<b>Fault Cause</b>	<b>Fault Handling Suggestion</b>
F78	CPLD Version Identification Error	CPLD version identification error.	Turn off the AC output side switch and DC input side switch, wait for 5 minutes, then turn on the AC output side switch and DC input side switch. If the fault persists, please contact the dealer or after-sales service center.
F79	CPLD Communication Fault	CPLD and DSP communication content error or timeout.	Turn off the AC output side switch and DC input side switch, wait for 5 minutes, then turn on the AC output side switch and DC input side switch. If the fault persists, please contact the dealer or after-sales service center.
F80	Model Identification Fault	Fault regarding model identification error.	Turn off the AC output side switch and DC input side switch, wait for 5 minutes, then turn on the AC output side switch and DC input side switch. If the fault persists, please contact the dealer or after-sales service center.

#### 8.5.2.1.3 Troubleshooting (Fault Codes F81-F121)

<b>Fault Code</b>	<b>Fault Name</b>	<b>Possible Cause</b>	<b>Recommended Action</b>
F81	P-Bus Overvoltage		Disconnect the AC output side switch and the DC input side switch, wait for 5 minutes, then close the AC output side switch and the DC input side switch. If the fault persists, please contact the dealer or after-sales service center.

Fault Code	Fault Name	Possible Cause	Recommended Action
F82	N-Bus Overvoltage	BUS overvoltage, possible causes: 1. PV voltage is too high; 2. Inverter BUS voltage sampling is abnormal; 3. Poor isolation effect of the dual-split transformer behind the inverter, causing mutual interference when two inverters are grid-connected, with one inverter reporting DC overvoltage during grid connection;	
F83	Bus Overvoltage (Sub CPU1)		Disconnect the AC output side switch and the DC input side switch, wait for 5 minutes, then close the AC output side switch and the DC input side switch. If the fault persists, please contact the dealer or after-sales service center.
F84	P-Bus Overvoltage (Sub CPU1)		

Fault Code	Fault Name	Possible Cause	Recommended Action
F85	N-Bus Overvoltage (Sub CPU1)	BUS overvoltage, possible causes: 1. PV voltage is too high; 2. Inverter BUS voltage sampling is abnormal; 3. Poor isolation effect of the dual-split transformer behind the inverter, causing mutual interference when two inverters are grid-connected, with one inverter reporting DC overvoltage during grid connection;	
F86	Bus Overvoltage (Sub CPU2)		Disconnect the AC output side switch and the DC input side switch, wait for 5 minutes, then close the AC output side switch and the DC input side switch. If the fault persists, please contact the dealer or after-sales service center.
F87	P-Bus Overvoltage (Sub CPU2)		

Fault Code	Fault Name	Possible Cause	Recommended Action
F88	N-Bus Overvoltage (Sub CPU2)	BUS overvoltage, possible causes: 1. PV voltage is too high; 2. Inverter BUS voltage sampling is abnormal; 3. Poor isolation effect of the dual-split transformer behind the inverter, causing mutual interference when two inverters are grid-connected, with one inverter reporting DC overvoltage during grid connection;	
F89	P-Bus Overvoltage (CPLD)		Disconnect the AC output side switch and the DC input side switch, wait for 5 minutes, then close the AC output side switch and the DC input side switch. If the fault persists, please contact the dealer or after-sales service center.

Fault Code	Fault Name	Possible Cause	Recommended Action
F90	N-Bus Overvoltage(CPLD)	BUS overvoltage, possible causes: 1. PV voltage is too high; 2. Inverter BUS voltage sampling is abnormal; 3. Poor isolation effect of the dual-split transformer behind the inverter, causing mutual interference when two inverters are grid-connected, with one inverter reporting DC overvoltage during grid connection;	
F91	FlyCap Software Overvoltage	Flying capacitor overvoltage, possible causes: 1. PV voltage is too high;	Disconnect the AC output side switch and the DC input side switch, wait for 5 minutes, then close the AC output side switch and the DC input side switch. If the fault persists, please contact the dealer or after-sales service center.
F92	FlyCap Hardware Overvoltage	2. Inverter flying capacitor voltage sampling is abnormal;	

<b>Fault Code</b>	<b>Fault Name</b>	<b>Possible Cause</b>	<b>Recommended Action</b>
F93	FlyCap Undervoltage	Flying capacitor undervoltage, possible causes: 1. Insufficient PV energy; 2. Inverter flying capacitor voltage sampling is abnormal;	Disconnect the AC output side switch and the DC input side switch, wait for 5 minutes, then close the AC output side switch and the DC input side switch. If the fault persists, please contact the dealer or after-sales service center.
F94	FlyCap Precharge Failure	Flying capacitor precharge failure, possible causes: 1. Insufficient PV energy; 2. Inverter flying capacitor voltage sampling is abnormal;	Disconnect the AC output side switch and the DC input side switch, wait for 5 minutes, then close the AC output side switch and the DC input side switch. If the fault persists, please contact the dealer or after-sales service center.
F95	FlyCap Precharge Abnormal	1. Unreasonable control loop parameters 2. Hardware damage	Disconnect the AC output side switch and the DC input side switch, wait for 5 minutes, then close the AC output side switch and the DC input side switch. If the fault persists, please contact the dealer or after-sales service center.

<b>Fault Code</b>	<b>Fault Name</b>	<b>Possible Cause</b>	<b>Recommended Action</b>
F96, F97	String Overcurrent(String 1-n) n: Determined based on the actual number of inverter strings	Possible causes: 1. String overcurrent; 2. String current sensor abnormality	Disconnect the AC output side switch and the DC input side switch, wait for 5 minutes, then close the AC output side switch and the DC input side switch. If the fault persists, please contact the dealer or after-sales service center.
F99, F100	String Missing(String 1-n) n: Determined based on the actual number of inverter strings	String fuse disconnected (if present)	Check if the fuse is disconnected.
F101	Battery 1 Precharge fault	Battery 1 precharge circuit fault (precharge resistor burned out, etc.)	Check if the precharge circuit is in good condition. After powering on the battery only, check if the battery voltage matches the bus voltage. If not, please contact the dealer or after-sales service center.
F102	Battery 1 Relay Failure	Battery 1 relay cannot operate normally	After powering on the battery, check if the battery relay is working and if a closing sound is heard. If it does not operate, please contact the dealer or after-sales service center.

<b>Fault Code</b>	<b>Fault Name</b>	<b>Possible Cause</b>	<b>Recommended Action</b>
F103	Battery 1 Connection Overvoltage	Battery 1 connection voltage exceeds the machine's rated range	Confirm if the battery voltage is within the machine's rated range.
F104	Battery 2 Precharge fault	Battery 2 precharge circuit fault (precharge resistor burned out, etc.)	Check if the precharge circuit is in good condition. After powering on the battery only, check if the battery voltage matches the bus voltage. If not, please contact the dealer or after-sales service center.
F105	Battery 2 Relay Failure	Battery 2 relay cannot operate normally	After powering on the battery, check if the battery relay is working and if a closing sound is heard. If it does not operate, please contact the dealer or after-sales service center.
F106	Battery 2 Connection Overvoltage	Battery 2 connection voltage exceeds the machine's rated range	Confirm if the battery voltage is within the machine's rated range.
F107	On-grid PWM Sync Failure	Abnormal during carrier synchronization grid connection	<ol style="list-style-type: none"> <li>1. Check if the sync line connection is normal</li> <li>2. Check if the master/slave settings are normal;</li> <li>3. Disconnect the AC output side switch and the DC input side switch, wait for 5 minutes, then close the AC output side switch and the DC input side switch. If the fault persists, please contact the dealer or after-sales service center.</li> </ol>
F108	DSP Communication fault	-	-

<b>Fault Code</b>	<b>Fault Name</b>	<b>Possible Cause</b>	<b>Recommended Action</b>
F109	External STS fault	Abnormal cable connection between inverter and STS	Check if the wiring sequence of the harness between the inverter and the STS corresponds one-to-one in order.
F110	Export Limit Protection	<ol style="list-style-type: none"> <li>1. Inverter reports error and disconnects from grid</li> <li>2. Meter communication is unstable</li> <li>3. Reverse power flow condition occurs</li> </ol>	<ol style="list-style-type: none"> <li>1. Check if the inverter has other error messages. If yes, handle them accordingly;</li> <li>2. Check if the meter connection is reliable;</li> <li>3. If this alarm occurs frequently, affecting normal power generation of the power station, please contact the dealer or after-sales service center.</li> </ol>
F111	Bypass Overload	-	-
F112	Black Start Failure	-	-
F113	Offgrid AC Ins Volt High	-	-
F114	Relay Failure2	Relay abnormality, causes: <ol style="list-style-type: none"> <li>1. Relay abnormality (relay short circuit)</li> <li>2. Relay sampling circuit abnormality.</li> <li>3. AC side wiring abnormality (may have poor connection or short circuit phenomenon)</li> </ol>	Disconnect the AC output side switch and the DC input side switch, wait for 5 minutes, then close the AC output side switch and the DC input side switch. If the fault persists, please contact the dealer or after-sales service center.
F115	SVG Precharge Disabled	SVG precharge hardware failure	Contact the dealer or after-sales service center.

<b>Fault Code</b>	<b>Fault Name</b>	<b>Possible Cause</b>	<b>Recommended Action</b>
F116	Nighttime SVG PID Prevention fault	PID prevention hardware abnormality	
F117	DSP Version Identification Error	DSP software version identification error	Disconnect the AC output side switch and the DC input side switch, wait for 5 minutes, then close the AC output side switch and the DC input side switch. If the fault persists, please contact the dealer or after-sales service center.
F118	MOS Continuous Overvoltage	<ol style="list-style-type: none"> <li>1. Software issue causing inverter drive to turn off earlier than flyback drive;</li> <li>2. Inverter drive circuit abnormality causing failure to turn on;</li> <li>3. PV voltage is too high;</li> <li>4. Mos voltage sampling abnormality;</li> </ol>	Disconnect the AC output side switch and the DC input side switch, wait for 5 minutes, then close the AC output side switch and the DC input side switch. If the fault persists, please contact the dealer or after-sales service center.
F119	Bus Short Circuit fault	Hardware damage	If the BUS short circuit fault occurs and the inverter remains off-grid, please contact the dealer or after-sales service center.

<b>Fault Code</b>	<b>Fault Name</b>	<b>Possible Cause</b>	<b>Recommended Action</b>
F120	Bus Sampling Abnormality	1. BUS voltage sampling hardware fault	Disconnect the AC output side switch and the DC input side switch, wait for 5 minutes, then close the AC output side switch and the DC input side switch. If the fault persists, please contact the dealer or after-sales service center.
F121	DC Side Sampling Abnormality	1. BUS voltage sampling hardware fault 2. Battery voltage sampling hardware fault 3. Dcrly relay fault	Disconnect the AC output side switch and the DC input side switch, wait for 5 minutes, then close the AC output side switch and the DC input side switch. If the fault persists, please contact the dealer or after-sales service center.

#### 8.5.2.1.4 Troubleshooting (Fault Codes F122-F163)

Fault Code	Fault Name	Fault Cause	Troubleshooting Recommendation
F122	PV Access Mode Setting Error	<p>There are three PV Access Modes, taking four MPPT channels as an example:</p> <ol style="list-style-type: none"> <li>1. Parallel Mode: i.e., AAAA mode (same-source mode), PV1-PV4 are from the same source, all 4 PV channels connect to the same solar panel.</li> <li>2. Partial Parallel Mode: i.e., AACC mode, PV1 and PV2 are from the same source, PV3 and PV4 are from the same source.</li> <li>3. Independent Mode: i.e., ABCD mode (different-source), PV1, PV2, PV3, PV4 connect independently, each of the 4 PV channels connects to one solar panel.</li> </ol> <p>This fault is reported if the actual PV connection mode</p>	<p>Check if the PV Access Mode is set correctly (ABCD, AACC, AAAA), and reset the PV Access Mode correctly.</p> <ol style="list-style-type: none"> <li>1. Confirm that each actual PV channel is correctly connected.</li> <li>2. If the PV connections are correct, check via the APP or screen whether the currently set "PV Access Mode" corresponds to the actual connection mode.</li> <li>3. If the currently set "PV Access Mode" does not match the actual connection mode, use the APP or screen to set the "PV Access Mode" to the mode consistent with the actual situation. After setting, disconnect and restart the PV and AC power supply.</li> <li>4. After setting, if the current "PV Access Mode" matches the actual connection mode but the fault persists, contact the dealer or after-sales service center.</li> </ol>

Fault Code	Fault Name	Fault Cause	Troubleshooting Recommendation
		does not match the PV Access Mode set on the device.	
F123	Multi-channel PV Phase Error	PV Input Mode setting error	<p>Check if the PV Access Mode is set correctly (ABCD, AACC, AAAA), and reset the PV Access Mode correctly.</p> <ol style="list-style-type: none"> <li>1. Confirm that each actual PV channel is correctly connected.</li> <li>2. If the PV connections are correct, check via the APP or screen whether the currently set "PV Access Mode" corresponds to the actual connection mode.</li> <li>3. If the currently set "PV Access Mode" does not match the actual connection mode, use the APP or screen to set the "PV Access Mode" to the mode consistent with the actual situation. After setting, disconnect and restart the PV and AC power supply.</li> <li>4. After setting, if the current "PV Access Mode" matches the actual connection mode but the fault persists, contact the dealer or after-sales service center.</li> </ol>
F124	Battery 1 Reverse Connection fault	Battery 1 positive and negative poles are reversed	Check if the polarities of the battery and the machine terminals are consistent.

<b>Fault Code</b>	<b>Fault Name</b>	<b>Fault Cause</b>	<b>Troubleshooting Recommendation</b>
F125	Battery 2 Reverse Connection fault	Battery 2 positive and negative poles are reversed	Check if the polarities of the battery and the machine terminals are consistent.
F126	Battery Abnormal Connection	Battery abnormal connection	Check if the battery is working normally.
F127	BAT Overtemperature	Battery temperature is too high, possible reasons: 1. Inverter installation location is not ventilated. 2. Ambient temperature is too high. 3. Internal fan operation is abnormal.	Disconnect the AC output side switch and the DC input side switch, close them after 5 minutes. If the fault still exists, contact the dealer or after-sales service center.
F128	Ref Voltage Abnormal	Reference circuit fault	Disconnect the AC output side switch and the DC input side switch, close them after 5 minutes. If the fault still exists, contact the dealer or after-sales service center.
F129	Cabinet Under Temperature	Cabinet temperature is too low, possible reason: ambient temperature is too low.	Disconnect the AC output side switch and the DC input side switch, close them after 5 minutes. If the fault still exists, contact the dealer or after-sales service center.
F130	AC Side SPD fault	AC side surge protective device failure	Replace the AC side surge protective device.

<b>Fault Code</b>	<b>Fault Name</b>	<b>Fault Cause</b>	<b>Troubleshooting Recommendation</b>
F131	DC Side SPD fault	DC side surge protective device failure	Replace the DC side surge protective device.
F132	Internal Fan Abnormal	Internal fan abnormal, possible reasons: 1. Fan power supply abnormal; 2. Mechanical fault (stall); 3. Fan aging or damage.	Disconnect the AC output side switch and the DC input side switch, close them after 5 minutes. If the fault still exists, contact the dealer or after-sales service center.
F133	External Fan Abnormal	External fan abnormal, possible reasons: 1. Fan power supply abnormal; 2. Mechanical fault (stall); 3. Fan aging or damage.	
F134	PID Diagnosis Abnormal	PID hardware fault or PV voltage too high causing PID pause	PID pause warning caused by high PV voltage requires no action. For PID hardware fault, clear the PID fault by turning the PID switch off and then on, and replace the PID device.

Fault Code	Fault Name	Fault Cause	Troubleshooting Recommendation
F135	Trip-Switch Trip Warning	Possible reasons: Overcurrent or PV reverse connection caused the trip-switch to trip;	Contact the dealer or after-sales service center; The trip reason is PV short circuit or reverse connection. Need to check if there is a historical PV short circuit warning or historical PV reverse connection warning. If exists, maintenance personnel need to check the corresponding PV condition. After checking and confirming no fault, the trip-switch can be manually closed, and clear this warning via the APP interface's clear historical fault operation.
F136	Historical PV IGBT Short Circuit Warning	Possible reasons: Overcurrent caused the trip-switch to trip;	Contact the dealer or after-sales service center; Maintenance personnel need to check the Boost hardware and external string for faults according to the historical PV short circuit warning subcode. After checking and confirming no fault, this warning can be cleared via the APP interface's clear historical fault operation.
F137 , F138	Historical PV Reverse Connection Warning (String 1-n) (n: determined by the actual number of inverter strings)	Possible reasons: PV reverse connection caused the trip-switch to trip;	Contact the dealer or after-sales service center; Maintenance personnel need to check the corresponding string for reverse connection and check the PV panel configuration for voltage difference according to the historical PV reverse connection warning subcode. After checking and confirming no fault, this warning can be cleared via the APP interface's clear historical fault operation.

<b>Fault Code</b>	<b>Fault Name</b>	<b>Fault Cause</b>	<b>Troubleshooting Recommendation</b>
F139	Flash Read/Write Error Warning	Possible reasons: 1. Flash content changed; 2. Flash life exhausted;	1. Upgrade to the latest firmware; 2. Contact the dealer or after-sales service center.
F140	Meter Comm Loss	This warning may only be reported after enabling anti-backflow function. Possible reasons: 1. Meter not connected; 2. Communication cable connection between meter and inverter is wrong.	Check the meter wiring, connect the meter correctly. If the fault persists after checking, contact the dealer or after-sales service center.
F141	PV Panel Type Identification Failure	PV panel identification hardware abnormal	Contact the dealer or after-sales service center.
F142	PV String Mismatch	PV string mismatch, two strings under the same MPPT channel have different open-circuit voltage configurations	Check the open-circuit voltage of the two strings, configure strings with the same open-circuit voltage under the same MPPT channel. Prolonged string mismatch poses safety risks.
F143	CT Not Connected	CT not connected	Check CT wiring.
F144	CT Reverse Connection	CT reverse connection	Check CT wiring.
F145	PE Loss	Protective earth (PE) not connected	Check the protective earth (PE) wire.

<b>Fault Code</b>	<b>Fault Name</b>	<b>Fault Cause</b>	<b>Troubleshooting Recommendation</b>
F146	String Terminal Temperature High (String 1~8)	Register 37176 PV terminal temperature alarm subcode 1 is set	-
F147	String Terminal Temperature High (String 9~16)	Register 37177 PV terminal temperature alarm subcode 2 is set	-
F148	String Terminal Temperature High (String 17~20)	Register 37178 PV terminal temperature alarm subcode 3 is set	-
F149	Historical PV Reverse Connection Warning (String 33~48)	Possible reasons: PV reverse connection caused the trip-switch to trip;	Contact the dealer or after-sales service center; Maintenance personnel need to check the corresponding string for reverse connection and check the PV panel configuration for voltage difference according to the historical PV reverse connection warning subcode. After checking and confirming no fault, this warning can be cleared via the APP interface's clear historical fault operation.
F150	Battery 1 Low Voltage	Battery voltage is below the set value	-
F151	Battery 2 Low Voltage	Battery voltage is below the set value	-

<b>Fault Code</b>	<b>Fault Name</b>	<b>Fault Cause</b>	<b>Troubleshooting Recommendation</b>
F152	Low Voltage of Battery Power	Battery in non-charging mode, voltage below shutdown voltage	-
F153	Battery 1 High Voltage	-	-
F154	Battery 2 High Voltage	-	-
F155	Online Low Insulation Resistance	<p>1. PV string short-circuited to protective earth.</p> <p>2. PV string installed in a long-term humid environment with poor line-to-earth insulation.</p>	<p>1. Check the impedance of the PV string to protective earth. If a short circuit is found, rectify the short circuit point.</p> <p>2. Check if the inverter's protective earth wire is correctly connected.</p> <p>3. If it is confirmed that the impedance is indeed below the default value in rainy conditions, please reset the "Insulation Resistance Protection Point".</p>
F156	Micro-grid Overload Warning	Backup port input current too high	Occasional occurrence requires no action; if this warning appears frequently, contact the dealer or after-sales service center.
F157	Manual Reset	-	-
F158	Generator Phase Sequence Abnormal	-	-

<b>Fault Code</b>	<b>Fault Name</b>	<b>Fault Cause</b>	<b>Troubleshooting Recommendation</b>
F159	Multiplexed Port Configuration Abnormal	Multiplexed (Generator) port is configured as micro-grid or large load, but a generator is actually connected	Use the APP to change the multiplexed (Generator) port configuration.
F160	EMS Forced Off-grid	EMS issued forced off-grid command, but off-grid function is not enabled	Enable the off-grid function.
F161	Passive Anti-islanding Protection	-	-
F162	Grid Type Fault	Actual grid type (two-phase or split-phase) does not match the set safety standard	Switch to the corresponding safety standard according to the actual grid type.
F163	Grid Phase Instability	Grid abnormal: Grid voltage phase change rate does not comply with local grid standard.	<p>1. If it occurs occasionally, it may be a temporary grid anomaly. The inverter will resume normal operation after detecting normal grid conditions, requiring no manual intervention.</p> <p>2. If it occurs frequently, check if the grid frequency is within the allowable range. If not, contact the local power operator.</p>

#### 8.5.2.1.5 Fault Symptom Handling

Fault Name	Fault Cause	Fault Handling Suggestion
Generator Failure	<ol style="list-style-type: none"> <li>1. This fault will be displayed continuously when no generator is connected.</li> <li>2. When the generator is operating, this fault will be triggered if generator safety regulations are not met.</li> </ol>	<ol style="list-style-type: none"> <li>1. Ignore this fault if no generator is connected;</li> <li>2. When this fault appears during a generator failure, it is normal. Wait for a period after the generator recovers, and the fault will clear automatically;</li> <li>3. This fault does not affect the normal operation of off-grid mode.</li> <li>4. When both generator and grid are connected and meet safety requirements, grid connection takes priority, and the system will operate in grid-connected mode.</li> </ol>
BMS Status Bit Error	BMS module failure	Disconnect the AC output side switch and DC input side switch, wait for 5 minutes, then close the AC output side switch and DC input side switch. If the fault persists, please contact the dealer or after-sales service center.
Ambient Overtemperature	<ol style="list-style-type: none"> <li>1. Poor ventilation of the machine</li> <li>2. Hot air flow back to the ambient temperature sampling point</li> </ol>	Disconnect the AC output side switch and DC input side switch, wait for 5 minutes, then close the AC output side switch and DC input side switch. If the fault persists, please contact the dealer or after-sales service center.

Fault Name	Fault Cause	Fault Handling Suggestion
PV Terminal Overtemperature	PV terminal overtemperature, possible causes: 1. Poor ventilation at the inverter installation location. 2. Ambient temperature is too high. 3. Internal fan operation is abnormal.	1. Check if the ventilation at the inverter installation location is adequate and if the ambient temperature exceeds the maximum allowable range. 2. If ventilation is poor or ambient temperature is too high, please improve ventilation and heat dissipation conditions. 3. If both ventilation and ambient temperature are normal, please contact the dealer or after-sales service center.
BAT Terminal Overtemperature	BAT terminal overtemperature, possible causes: 1. Poor ventilation at the inverter installation location. 2. Ambient temperature is too high.	1. Check if the ventilation at the inverter installation location is adequate and if the ambient temperature exceeds the maximum allowable range.
AC Terminal Overtemperature Warning	AC terminal overtemperature, possible causes: 1. Poor ventilation at the inverter installation location. 2. Ambient temperature is too high. 3. Internal fan operation is abnormal.	2. If ventilation is poor or ambient temperature is too high, please improve ventilation and heat dissipation conditions. 3. If both ventilation and ambient temperature are normal, please contact the dealer or after-sales service center.

<b>Fault Name</b>	<b>Fault Cause</b>	<b>Fault Handling Suggestion</b>
BAT Terminal Overtemperature Warning	BAT terminal overtemperature, possible causes: 1. Poor ventilation at the inverter installation location. 2. Ambient temperature is too high.	1. Check if the ventilation at the inverter installation location is adequate and if the ambient temperature exceeds the maximum allowable range. 2. If ventilation is poor or ambient temperature is too high, please improve ventilation and heat dissipation conditions. 3. If both ventilation and ambient temperature are normal, please contact the dealer or after-sales service center.
Three-phase on-grid fault	Three-phase external wiring error	Re-wire the connections.
External STS Failure	Abnormal connection cable between inverter and STS	Check if the wiring sequence of the harness connecting the inverter and the STS corresponds one-to-one in order.

<b>Fault Name</b>	<b>Fault Cause</b>	<b>Fault Handling Suggestion</b>
Parallel Comm Timeout Shutdown	In parallel mode, if a slave unit has not communicated with the master for over 400 seconds	Check if the parallel communication harness is securely connected. Check for duplicate slave addresses.
Three-phase off-grid phase loss fault	Phase loss in a three-phase system group	1. Check if all inverters are powered on; 2. Check if each phase in the three-phase group is connected to an inverter;

Fault Name	Fault Cause	Fault Handling Suggestion
EPO	External trigger of hardware EPO button or remote trigger of EPO command	<ol style="list-style-type: none"> <li>1. If it was actively triggered by remote shutdown, it can be ignored;</li> <li>2. If not actively triggered, please contact the distributor or after-sales service center.</li> </ol>
High combustible gas concentration	Automatically triggered when the combustible gas device detects a concentration of 20% LEL or higher	<ol style="list-style-type: none"> <li>1. After the fault occurs, the unit will automatically open the air damper to ventilate and reduce the concentration. The fault will automatically clear after the concentration remains below 5% LEL for 15 minutes.</li> <li>2. If a cluster-level fire protection fault is triggered after this fault occurs, the air damper will automatically close. Confirm the damper status within 30s to ensure the cluster-level fire protection operates in an enclosed space.</li> <li>3. Please contact the distributor or after-sales service center.</li> </ol>
Mismatch between air damper open command and feedback signal for combustible gas device	Mismatch between the control signal to open the air damper and the feedback signal	<ol style="list-style-type: none"> <li>1. Check the harness signal connection for issues.</li> <li>2. Please contact the distributor or after-sales service center.</li> </ol>
One-touch shutdown	Check via the App if the one-touch shutdown function is enabled	Disable the one-touch shutdown.

Fault Name	Fault Cause	Fault Handling Suggestion
Offline shutdown	-	-
Remote shutdown	-	-
On-Grid SPD Fault	-	<ol style="list-style-type: none"> <li>1. Try restarting the unit and observe if the fault clears;</li> <li>2. If the fault persists after restarting, please contact the distributor or after-sales service center.</li> </ol>
Off-Grid SPD Fault	-	<ol style="list-style-type: none"> <li>1. Try restarting the unit and observe if the fault clears;</li> <li>2. If the fault persists after restarting, please contact the distributor or after-sales service center.</li> </ol>
Child Node Communication Failure	Internal Comm Abnormal	<ol style="list-style-type: none"> <li>1. Try restarting the unit and observe if the fault clears;</li> <li>2. If the fault persists after restarting, please contact the distributor or after-sales service center.</li> </ol>
Dehumidifier communication fault	Abnormal communication link between the dehumidifier and the LC control box	<ol style="list-style-type: none"> <li>1. Check the link communication harness and observe if the fault clears;</li> <li>2. Try restarting the unit and observe if the fault clears;</li> <li>3. If the fault persists after restarting, please contact the distributor or after-sales service center.</li> </ol>

Fault Name	Fault Cause	Fault Handling Suggestion
Combustible gas detection device communication fault	<ol style="list-style-type: none"> <li>1. The combustible gas device was not properly configured with the 485 address set to 2 during factory settings.</li> <li>2. Abnormal communication link between the combustible gas device and the LC control box</li> </ol>	<ol style="list-style-type: none"> <li>1. Check the link communication harness and observe if the fault clears;</li> <li>2. Try restarting the unit and observe if the fault clears;</li> <li>3. Use the method provided by the combustible gas manufacturer to check if the device address is 2. If not, modify it;</li> <li>4. If the fault persists after restarting, please contact the distributor or after-sales service center.</li> </ol>
DG Communication Failure	Abnormal communication link between the control board and the diesel generator	<ol style="list-style-type: none"> <li>1. Check the link communication harness and observe if the fault clears;</li> <li>2. Try restarting the unit and observe if the fault clears;</li> <li>3. If the fault persists after restarting, please contact the distributor or after-sales service center.</li> </ol>
Battery Over Voltage	<ol style="list-style-type: none"> <li>1. Single cell voltage too high</li> <li>2. Abnormal voltage sensing line</li> </ol>	Record the fault phenomenon, restart the battery, wait a few minutes, and confirm if the fault disappears. If the problem persists after restarting, please contact the after-sales service center.
Battery Undervoltage	<ol style="list-style-type: none"> <li>1. Total battery voltage too high</li> <li>2. Abnormal voltage sensing line</li> </ol>	
	<ol style="list-style-type: none"> <li>1. Single cell voltage too low</li> <li>2. Abnormal voltage sensing line</li> </ol>	

Fault Name	Fault Cause	Fault Handling Suggestion
	1. Total battery voltage too low 2. Abnormal voltage sensing line	
Battery Overcurrent	1. Charging current too high, abnormal battery current limiting: sudden changes in temperature and voltage values 2. Inverter response abnormal	
	Battery discharge current too high	
Battery Overtemperature	1. Ambient Overtemperature 2. Abnormal temperature sensor	
Battery Undertemperature	1. Ambient temperature too low 2. Abnormal temperature sensor	
Battery Terminal Overtemperature	Terminal temperature too high	

Fault Name	Fault Cause	Fault Handling Suggestion
Battery Imbalance	<ol style="list-style-type: none"> <li>1. Excessive temperature difference. At different stages, the battery will limit its power, i.e., limit charge/discharge current. Therefore, this issue is generally difficult to occur.</li> <li>2. Cell capacity degradation leads to excessive internal resistance, causing large temperature rise during overcurrent and thus large temperature difference.</li> <li>3. Poor welding of cell tabs leads to rapid cell temperature rise during overcurrent.</li> <li>4. Temperature sampling issue;</li> <li>5. Loose power line connection</li> </ol>	

Fault Name	Fault Cause	Fault Handling Suggestion
	1. Inconsistent cell aging levels 2. Slave board chip issues can also cause excessive cell voltage difference; 3. Slave board balancing issues can also cause excessive cell voltage difference 4. Caused by harness issues	
Insulation Resistance	Insulation resistance damaged	Check if the ground wire is properly connected, restart the battery. If the problem persists after restarting, please contact the after-sales service center.
Pre-charging Failure	Pre-charging Failure	Indicates that during pre-charging, the voltage across the pre-charge MOS always exceeds the specified threshold. After powering off and restarting, observe if the fault persists. Check if wiring is correct and if the pre-charge MOS is damaged.
Sensing line fault	Battery sensing line poor contact or disconnected	Check wiring, restart the battery. If the problem persists after restarting, please contact the after-sales service center.
	Cell voltage sensing line poor contact or disconnected	Check wiring, restart the battery. If the problem persists after restarting, please contact the after-sales service center.
	Cell temperature sensing line poor contact or disconnected	

Fault Name	Fault Cause	Fault Handling Suggestion
	Dual-channel current comparison error too large, or abnormal current sensing line loop	
	Dual-channel voltage comparison error too large or MCU vs. AFE voltage comparison error too large, or abnormal voltage sensing line loop	
	Temperature sensing line loop abnormal or poor contact/disconnected	
	Overvoltage level 5 or overtemperature level 5, tripping the three-terminal fuse	The three-terminal fuse is blown. Please contact the after-sales service center to replace the main control board.
Relay or MOS overtemperature	Relay or MOS overtemperature	This fault indicates the MOS tube temperature exceeds the specified threshold. Power off and let it sit for 2 hours for temperature recovery.
Shunt overtemperature	Shunt overtemperature	This fault indicates the shunt temperature exceeds the specified threshold. Power off and let it sit for 2 hours for temperature recovery.

Fault Name	Fault Cause	Fault Handling Suggestion
BMS1 Other Faults 1 (Residential Storage)	Relay or MOS open circuit	<ol style="list-style-type: none"> <li>1. Upgrade software, power off and let it sit for 5 minutes, restart and see if the fault persists;</li> <li>2. If it persists, replace the battery pack</li> </ol>
	Relay or MOS short circuit	<ol style="list-style-type: none"> <li>1. Upgrade software, power off and let it sit for 5 minutes, restart and see if the fault persists;</li> <li>2. If it persists, replace the battery pack</li> </ol>
	Communication abnormal between master and slave clusters or cell inconsistency between clusters	<ol style="list-style-type: none"> <li>1. Check the slave battery information, software version, and if the communication cable connection to the master is normal</li> <li>2. Upgrade software</li> </ol>
	Battery system loop harness abnormal, causing interlock signal loop not formed	Check if the terminal resistor is installed correctly
	BMS and PCS communication abnormal	<ol style="list-style-type: none"> <li>1. Confirm if the communication cable interface definition between the inverter and the connected battery is correct;</li> <li>2. Please contact the after-sales service center, check backend data, and observe if the inverter and battery software are correctly matched.</li> </ol>
	BMS master and slave control communication harness abnormal	<ol style="list-style-type: none"> <li>1. Check wiring, restart the battery;</li> <li>2. Upgrade the battery software. If the problem persists after restarting, please contact the after-sales service center.</li> </ol>

Fault Name	Fault Cause	Fault Handling Suggestion
	Communication loss between main negative chips	
	Circuit breaker, shunt trip abnormal	<ol style="list-style-type: none"> <li>1. Power off and let it sit for 5 minutes, restart and see if the fault persists;</li> <li>2. Observe the PACK and PCU bottom blind-mate connectors, check if communication pins are loose or bent;</li> </ol>
	MCU self-test failure	Upgrade software, restart the battery. If the problem persists after restarting, please contact the after-sales service center.
	<ol style="list-style-type: none"> <li>1. Software version too low or BMS board damaged</li> <li>2. Large number of inverters in parallel, causing excessive inrush current during battery pre-charge</li> </ol>	<ol style="list-style-type: none"> <li>1. Upgrade software, observe if the fault persists.</li> <li>2. If in parallel configuration, start the battery in black start mode first, then start the inverters.</li> </ol>
	MCU internal fault	Upgrade software, restart the battery. This usually indicates MCU or external component damage. If the problem persists after restarting, please contact the after-sales service center.
	Total control current exceeds specified threshold	<ol style="list-style-type: none"> <li>1. Power off and let it sit for 5 minutes, restart and see if the fault persists;</li> <li>2. Check if the inverter power setting is too high, causing the bus load to be exceeded;</li> </ol>

Fault Name	Fault Cause	Fault Handling Suggestion
	Inconsistent cells in parallel clusters	Confirm if the cells in the parallel clusters are consistent.
	Reverse polarity connection of parallel cluster batteries	Check if the positive and negative terminals of the parallel cluster batteries are reversed.
	Severe overtemperature/overvoltage etc. triggering fire protection system	Contact the after-sales service center.
Air Conditioner Failure	Air conditioner abnormal failure	Try restarting the system. If the fault is not resolved, please contact the after-sales service center.
	Cabinet door not closed	Check if the cabinet door is properly closed
	Supply voltage too high	Confirm if the supply voltage meets the air conditioner input voltage requirements. Confirm compliance before reapplying power.
	Insufficient supply voltage	
	No voltage input	
	Unstable supply voltage	Try restarting the system. If the fault is not resolved, please contact the after-sales service center.
	Compressor voltage unstable	
	Sensor poor contact or damaged	
	Air conditioner fan abnormal	

Fault Name	Fault Cause	Fault Handling Suggestion
BMS1 Other Faults 2 (Residential Storage)	Internal voltage or current abnormal in DCDC	Refer to specific DC fault content.
	DCDC overload or heatsink overtemperature, etc.	
	Cell sensing abnormal or inconsistent aging levels	Please contact the after-sales service center.
	Fan action not executed normally	Please contact the after-sales service center.
	Output port screw loose or poor contact	<ol style="list-style-type: none"> <li>1. Power off the battery, check wiring and output port screw condition.</li> <li>2. After confirmation, restart the battery, observe if the fault persists. If it persists, please contact the after-sales service center.</li> </ol>
	Battery used for too long or cells severely damaged	Please contact the after-sales service center to replace the pack.
	<ol style="list-style-type: none"> <li>1. Software version too low or BMS board damaged</li> <li>2. Large number of inverters in parallel, causing excessive inrush current during battery pre-charge</li> </ol>	<ol style="list-style-type: none"> <li>1. Upgrade software, observe if the fault persists.</li> <li>2. If in parallel configuration, start the battery in black start mode first, then start the inverters.</li> </ol>
	Heating film damaged	Please contact the after-sales service center.

Fault Name	Fault Cause	Fault Handling Suggestion
	Heating film three-terminal fuse blown, heating function unavailable	Please contact the after-sales service center.
	Software model, Cell Type, hardware model mismatch	Check if the software model, SN, Cell Type, and hardware model are consistent. If not, please contact the after-sales service center.
	Thermal management board communication line break	1. Power off and let it sit for 5 minutes, restart and see if the fault persists; 2. If the fault does not recover, contact after-sales to replace the pack.
	Pack fan fault signal triggered	
DCDC fault	Output port voltage too high	Check the output port voltage. If the voltage is normal and the fault does not clear itself after restarting the battery, please contact the after-sales service center.
	DCDC module detects battery voltage exceeding maximum charging voltage	Stop charging, discharge to below 90% SOC or let it sit for 2 hours. If ineffective and the fault persists after restarting, please contact the after-sales service center.
	Heatsink temperature too high	Let the battery sit for 1 hour for heatsink temperature to drop. If ineffective and the fault persists after restarting, please contact the after-sales service center.
	Battery discharge current too high	Check if the load exceeds the battery's discharge capability. Turn off the load or stop PCS operation for 60s. If ineffective and the fault persists after restarting, please contact the after-sales service center.

Fault Name	Fault Cause	Fault Handling Suggestion
	Output port power harness positive/negative reversed with parallel cluster battery or PCS	Turn off the battery manual switch, check if the output port wiring is correct, restart the battery.
	Output power relay cannot close	Check if the output port wiring is correct and if there is a short circuit. If ineffective and the fault persists after restarting, please contact the after-sales service center.
	Power device temperature too high	Let the battery sit for 1 hour for internal power device temperature to drop. If ineffective and the fault persists after restarting, please contact the after-sales service center.
	Relay welded/stuck	If the fault persists after restarting, please contact the after-sales service center.
Battery Rack Circulating Current Failure	1. Cell imbalance 2. First power-on without full charge calibration	Record the fault phenomenon, restart the battery, wait a few minutes, and confirm if the fault disappears. If the problem persists after restarting, please contact the after-sales service center.
BMS1 Other Faults 3 (Large-scale Storage)	Communication abnormal with linux module	1. Check if the communication cable link is normal. 2. Upgrade software, restart the battery and observe if the fault persists. If it persists, please contact the after-sales service center.
	Cell temperature rise too fast	Cell abnormal, contact after-sales to replace the pack.
	SOC below 10%	Charge the battery.

Fault Name	Fault Cause	Fault Handling Suggestion
	SN writing does not comply with rules	Check if the SN digit count is normal. If abnormal, please contact the after-sales service center.
	1. Communication abnormal in battery cluster daisy chain 2. Inconsistent cell aging levels between battery clusters	1. Check the pack contact condition within a single cluster. 2. Confirm the usage of each cluster, such as cumulative charge/discharge capacity, cycle count, etc. 3. Please contact the after-sales service center.
	High humidity inside pack	-
	Fuse blown	Contact after-sales to replace the pack.
	Battery low power	Charge the battery.
BMS1 Other Faults 4 (Large-scale Storage)	Circuit breaker abnormal	Contact after-sales to replace the pack.
	External device abnormal	Contact after-sales to replace the pack.
Contactor Failure 1	-	-
Contactor Failure 2	-	-
Overload Protection (Ksic)	Sustained overload (over 690KVA) for 10s	Please contact the after-sales service center.
Overload protection (Smart port)	Sustained overload (over 690KVA) for 10s	Please contact the after-sales service center.

<b>Fault Name</b>	<b>Fault Cause</b>	<b>Fault Handling Suggestion</b>
Overcurrent protection (Ksic)	-	-
Overcurrent protection (Smart port)	-	-
Master AC On Meter Comm Error	<ol style="list-style-type: none"> <li>1. Possibly the meter is not connected to the master</li> <li>2. Possibly the meter communication cable is loose</li> </ol>	<ol style="list-style-type: none"> <li>1. Check if the meter is connected to the master</li> <li>2. Check if the meter communication cable is loose</li> </ol>
Parallel Slave Meter Error	Meter connected to slave unit	Set the machine with the meter as the master
Slave AC On Timeout with Master	<ol style="list-style-type: none"> <li>1. Slave address setting error</li> <li>2. Slave communication cable loose</li> </ol>	<ol style="list-style-type: none"> <li>1. Check for duplicate slave addresses</li> <li>2. Check if the parallel communication cable is loose</li> </ol>

### 8.5.2.2 Batteryfault

No.	fault name	fault cause	Troubleshooting Recommendation
1	BMS1 Cluster 1 Total voltage Over WARNING /BMS1 RACK1 Total voltage is too high warning	<ol style="list-style-type: none"> <li>1. Battery systemvoltage too high</li> <li>2. Abnormal collection line</li> </ol>	<ol style="list-style-type: none"> <li>1. Perform Discharge on Battery to check if fault persists.</li> <li>2. If the fault is not restored, contact the after-sales service center.</li> </ol>
2	BMS1 Cluster 1 Total voltage Too Low WARNING /BMS1 RACK1 Total voltage is too low warning	<ol style="list-style-type: none"> <li>1. Battery systemvoltage too low</li> <li>2. Abnormal data collection line</li> </ol>	<ol style="list-style-type: none"> <li>1. Perform Charge on Battery, and observe whether fault persists after standing;</li> <li>2. Determine the working condition of Inverter, check if it fails to supply power to Battery charge due to issues such as working mode, and attempt to supply power to Battery charge via Inverter, observing whether fault is restored.</li> <li>3. If the fault is not restored, contact the after-sales service center.</li> </ol>

No.	fault name	fault cause	Troubleshooting Recommendation
3	BMS1 Cluster 1 Cell voltage Overvoltage WARNING /BMS1 RACK1 Cell voltage is too high warning	1. Single cell voltage too high 2. Abnormal collection line	1. Perform Discharge on Battery, and observe whether fault persists after standing. 2. If fault is not restored, contact the after-sales service center.
4	BMS1 Cluster 1 Cell voltage Undervoltage WARNING /BMS1 RACK1 Cell voltage is too low warning	1. Single cell voltage too low 2. voltage collection line abnormality	1. Perform Charge on Battery, and observe whether fault persists after standing; 2. Determine the working condition of Inverter, check if it is not supplying power to Battery charge due to issues such as working mode, and attempt to supply power to Battery charge via Inverter, observing whether fault is restored. 3. If fault is not restored, contact after-sales service.

No.	fault name	fault cause	Troubleshooting Recommendation
5	BMS1 Cluster 1 Charge Over Temperature WARNING /BMS1 RACK1 Charging temperature is too high warning	<ol style="list-style-type: none"> <li>1. Ambient Overtemperature</li> <li>2. Temperature sensor abnormality</li> </ol>	<ol style="list-style-type: none"> <li>1. Stop charging and observe whether the Discharge persists during rest;</li> <li>2. If the fault is not restored, contact the after-sales service center.</li> </ol>
6	BMS1 Cluster 1 Discharge Over Temperature WARNING /BMS1 RACK1 Discharging temperature is too high warning	<ol style="list-style-type: none"> <li>1. Ambient Overtemperature</li> <li>2. Temperature sensor abnormality</li> </ol>	<ol style="list-style-type: none"> <li>1. Stop charging, let it stand and observe whether the fault persists;</li> <li>2. If the fault is not restored, contact after-sales service.</li> </ol>

No.	fault name	fault cause	Troubleshooting Recommendation
7	BMS1 Cluster 1 Charge Temperature Too Low WARNING /BMS1 RACK1 Charging temperature is too low warning	<ol style="list-style-type: none"> <li>1. Ambient temperature too low</li> <li>2. Temperature sensor abnormality</li> </ol>	<ol style="list-style-type: none"> <li>1. Check the cell temperature in the background. If the minimum temperature is higher than -20°C, set Battery discharge to increase the cell temperature.</li> <li>2. If the temperature is below -20°C, shut down the Battery and place it in a warm environment. Use it only after the battery cell temperature has recovered.</li> <li>3. If none of the above works, contact the after-sales service center.</li> </ol>

No.	fault name	fault cause	Troubleshooting Recommendation
8	BMS1 cluster 1 Discharge temperature too low WARNING/ BMS1 RACK1 Discharging temperature is too low warning	<ol style="list-style-type: none"> <li>1. Ambient temperature too low</li> <li>2. Temperature sensor abnormality</li> </ol>	<ol style="list-style-type: none"> <li>1. Check the cell temperature in the background. If the minimum temperature is higher than -20°C, set Battery discharge to increase the cell temperature.</li> <li>2. If the temperature is below -20°C, shut down the Battery and place it in a warm environment. Use it only after the battery cell temperature has recovered.</li> <li>3. If none of the above works, contact the after-sales service center.</li> </ol>
9	BMS1 Cluster 1 Overcurrent BMS1 RACK1 Charge overcurrent warning	<ol style="list-style-type: none"> <li>1. Charging Current is too large, Battery current limiting is abnormal: temperature and voltage value mutation</li> <li>2. Inverter response anomaly</li> </ol>	<ol style="list-style-type: none"> <li>1. Stop Charge and observe whether fault persists;</li> <li>2. Check if the Inverter is set with an excessively large Power, causing it to exceed the rated operating current of the Battery;</li> <li>3. If continuous overcurrent occurs, contact the after-sales service center.</li> </ol>

No.	fault name	fault cause	Troubleshooting Recommendation
10	BMS1 Cluster 1 Overcurrent BMS1 RACK1 Discharge overcurrent warning	<ol style="list-style-type: none"> <li>1. Discharge and current are too large, Battery current limiting is abnormal: temperature and voltage values have changed abruptly.</li> <li>2. Inverter response anomaly</li> </ol>	<ol style="list-style-type: none"> <li>1. Stop Discharge, let it stand and observe whether fault persists;</li> <li>2. Check if the Inverter is set with an excessively large Power, causing it to exceed the rated operating current of the Battery;</li> <li>3. If continuous overcurrent occurs, contact the after-sales service center.</li> </ol>
11	BMS1 Cluster 1 Insulation Resistance Low WARNING/ BMS1 RACK1 Insulation resistance is too low warning	Insulation resistance damage or abnormal contact	Check if the ground wire is properly connected and restart the Battery. If the issue persists after restarting, please contact the after-sales service center.

No.	fault name	fault cause	Troubleshooting Recommendation
12	BMS1 Cluster 1 Single Cell Temperature Difference Exceeds Limit WARNING BMS1 RACK1 Cell excessive temperature differentials warning	<ol style="list-style-type: none"> <li>1. Excessive temperature difference at different stages will result in Battery limiting the Battery Power, specifically restricting the charging Discharge current. Therefore, this issue is generally unlikely to occur.</li> <li>2. Cell capacity degradation leads to excessive internal resistance, resulting in significant temperature rise and large temperature differences during Overcurrent.</li> <li>3. Poor welding of the cell tabs leads to excessive heating of the Overcurrent cell.</li> <li>4. Temperature sampling issue;</li> <li>5. Loose connection of power cable</li> </ol>	Shut down, restart Battery, and wait for 2 hours. If the issue persists, contact the after-sales service center.

No.	fault name	fault cause	Troubleshooting Recommendation
13	BMS1 Cluster 1 Pole Temperature Too High WARNING BMS1 RACK1 Post temperature is too high warning	Pole temperature too high	1. Stop charging, let it stand and observe whether the fault persists; 2. If fault is not restored, contact the after-sales service center.
14	BMS1 cluster 1 cell voltage difference too highWARNING/ BMS1 RACK1 Cell excessive voltage differentials warning	<ol style="list-style-type: none"> <li>1. Inconsistent aging levels of battery cells</li> <li>2. Issues with the board chip can also lead to excessive voltage differences between battery cells.</li> <li>3. Cell imbalance can also lead to excessive voltage differences between cells.</li> <li>4. Harness issue causing</li> </ol>	<ol style="list-style-type: none"> <li>1. Stop charging, let it stand and observe whether the fault persists;</li> <li>2. If fault is not restored, contact the after-sales service center.</li> </ol>
15	BMS1 Cluster 1PCS Comm LossWARNING/ BMS1 RACK1 PCS communication loss warning	BMS and PCS communication abnormality	Check whether the communication line connection between Battery and Inverter is intact.

No.	fault name	fault cause	Troubleshooting Recommendation
16	BMS1 Cluster 1 DCDCWARNING/ BMS1 RACK1 DCDC warning	There is an abnormality in the voltage or current inside the DCDC.	Upgrade the software and restart the Battery. If the issue persists after restarting, please contact the after-sales service center.
17	BMS1 Cluster 1 Heating Film MOS Adhesion WARNING BMS1 RACK1 Heat film MOS adhesion warning	Heating film MOS damage	Please contact the after-sales service center.
18	BMS1 Cluster 1 Heating Film MOS Open Circuit WARNING/ BMS1 RACK1 Heat film MOS open warning	Heating circuit abnormality	Please contact the after-sales service center.
19	BMS1 Cluster 1 Total voltage Over fault/ BMS1 RACK1 Total voltage is too high fault	1. Battery systemvoltage too high 2. voltage collection line abnormality	1. Perform Discharge on Battery to check if fault persists. 2. If fault is not restored, please contact the after-sales service center.

No.	fault name	fault cause	Troubleshooting Recommendation
20	BMS1 Cluster 1 Total voltage Too Low fault/ BMS1 RACK1 Total voltage is too low fault	<ol style="list-style-type: none"> <li>1. Battery system voltage too low</li> <li>2. voltage collection line abnormality</li> </ol>	<ol style="list-style-type: none"> <li>1. Perform Charge on Battery, and observe whether fault persists after standing;</li> <li>2. Determine the working condition of Inverter, check if it fails to supply power to Battery charge due to issues such as working mode, and attempt to supply power to Battery charge via Inverter, observing whether fault is restored.</li> <li>3. If the fault is not restored, please contact the after-sales service center.</li> </ol>
21	BMS1 Cluster 1 Cell voltage Overvoltage fault BMS1 RACK1 Cell voltage is too high fault	<ol style="list-style-type: none"> <li>1. Single cell voltage too high</li> <li>2. voltage collection line abnormality</li> </ol>	<ol style="list-style-type: none"> <li>1. Perform Discharge on Battery, and observe whether fault persists after standing.</li> <li>2. If fault is not restored, please contact the after-sales service center.</li> </ol>

No.	fault name	fault cause	Troubleshooting Recommendation
22	BMS1 Cluster 1 Monomer voltage Undervoltage fault/ BMS1 RACK1 Cell voltage is too low fault	<ol style="list-style-type: none"> <li>1. Single cell voltage too low</li> <li>2. Abnormal voltage collection line</li> </ol>	<ol style="list-style-type: none"> <li>1. Perform Charge on Battery, and observe whether fault persists after standing;</li> <li>2. Determine the working condition of Inverter, check if it fails to supply power to Battery charge due to issues such as working mode, and attempt to supply power to Battery charge via Inverter, observing whether fault is restored.</li> <li>3. If the fault is not restored, please contact the after-sales service center.</li> </ol>
23	BMS1 Cluster 1 Charge Over Temperature fault/ BMS1 RACK1 Charging temperature is too high fault	<ol style="list-style-type: none"> <li>1. Ambient Overtemperature</li> <li>2. Temperature sensor abnormality</li> </ol>	<ol style="list-style-type: none"> <li>1. Place the Battery in a cool place, let it shut down and rest for 30 minutes, then restart it to see if the fault persists.</li> <li>2. If the fault persists, please contact the after-sales service center.</li> </ol>

No.	fault name	fault cause	Troubleshooting Recommendation
24	BMS1 Cluster 1 Discharge Over Temperature fault/ BMS1 RACK1 Discharging temperature is too high fault	<ol style="list-style-type: none"> <li>1. Ambient Overtemperature</li> <li>2. Temperature sensor abnormality</li> </ol>	<ol style="list-style-type: none"> <li>1. Place the Battery in a cool place, let it shut down and rest for 30 minutes, then restart it to see if the fault persists;</li> <li>2. If the fault persists, please contact the after-sales service center.</li> </ol>
25	BMS1 Cluster 1 Charge Temperature Too Low fault/ BMS1 RACK1 Charging temperature is too low fault	<ol style="list-style-type: none"> <li>1. Ambient temperature too low</li> <li>2. Temperature sensor abnormality</li> </ol>	<ol style="list-style-type: none"> <li>1. Check the cell temperature in the background. If the minimum temperature is higher than -20°C, set Battery discharge to increase the cell temperature.</li> <li>2. If the temperature is below -20°C, shut down the Battery and place it in a warm environment. Use it only after the battery cell temperature has recovered.</li> <li>3. If none of the above works, contact the after-sales service center.</li> </ol>

No.	fault name	fault cause	Troubleshooting Recommendation
26	BMS1 Cluster 1 Discharge Temperature Too Low fault BMS1 RACK1 Discharging temperature is too low fault	<ol style="list-style-type: none"> <li>1. Ambient temperature too low</li> <li>2. Temperature sensor abnormality</li> </ol>	<ol style="list-style-type: none"> <li>1. Check the cell temperature in the background. If the minimum temperature is higher than -20°C, set Battery discharge to increase the cell temperature.</li> <li>2. If the temperature is below -20°C, shut down the Battery and place it in a warm environment. Use it only after the battery cell temperature has recovered.</li> <li>3. If none of the above works, contact the after-sales service center.</li> </ol>
27	BMS1 Cluster 1 Overcurrent BMS1 RACK1 Charge overcurrent fault	<ol style="list-style-type: none"> <li>1. Charging Current is too large, Battery current limiting is abnormal: temperature and voltage value mutation</li> <li>2. Inverter response anomaly</li> </ol>	<ol style="list-style-type: none"> <li>Let the system stand and shut down for 5 minutes, then restart to check if fault persists.</li> <li>2. Check if the Inverter is set with an excessively large Power, causing it to exceed the rated operating current of the Battery;</li> <li>3. If continuous overcurrent occurs, contact the after-sales service center.</li> </ol>

No.	fault name	fault cause	Troubleshooting Recommendation
28	BMS1 Cluster 1 Discharge Overcurrent fault / BMS1 RACK1 Discharge overcurrent fault	<ol style="list-style-type: none"> <li>1. Discharge and current are too large, Battery current limiting is abnormal: temperature and voltage values have changed abruptly.</li> <li>2. Inverter response anomaly</li> </ol>	<ol style="list-style-type: none"> <li>1. Let the system remain powered off for 5 minutes, then restart and check if fault persists;</li> <li>2. Check if the Inverter is set with an excessively large Power, causing it to exceed the rated operating current of the Battery;</li> <li>3. If continuous overcurrent occurs, contact the after-sales service center.</li> </ol>
29	BMS1 Cluster 1 Insulation Resistance Low fault BMS1 RACK1 Insulation resistance is too low fault	Insulation resistance damage or abnormal contact	<ol style="list-style-type: none"> <li>1. Check if the ground wire is properly connected and restart the Battery,</li> <li>2. Upgrade the software. If the problem persists, please contact the after-sales service center.</li> </ol>

No.	fault name	fault cause	Troubleshooting Recommendation
30	BMS1 Cluster 1 Single Cell Temperature Difference Exceeds Limit fault BMS1 RACK1 Cell excessive temperature differentials fault	<ol style="list-style-type: none"> <li>1. Excessive temperature difference at different stages will result in Battery limiting the Battery Power, specifically restricting the charging Discharge current. Therefore, this issue is generally unlikely to occur.</li> <li>2. Cell capacity degradation leads to excessive internal resistance, resulting in significant temperature rise and large temperature differences during Overcurrent.</li> <li>3. Poor welding of the cell tabs leads to excessive heating of the Overcurrent cell.</li> <li>4. Temperature sampling issue;</li> <li>5. Loose connection of power cable</li> </ol>	Shutdown, restart Battery, wait for 2 hours. If the issue persists, contact the after-sales service center.

No.	fault name	fault cause	Troubleshooting Recommendation
31	BMS1 Cluster 1 Pole Temperature Too High fault BMS1 RACK1 Post temperature is too high fault	Pole temperature too high	<ol style="list-style-type: none"> <li>1. Let the system remain powered off and idle for 30 minutes, then restart to check if fault persists;</li> <li>2. If the fault persists, please contact the after-sales service center.</li> </ol>
32	BMS1 Cluster 1 Excessive Cell Voltage Difference fault/ BMS1 RACK1 Cell excessive voltage differentials fault	<ol style="list-style-type: none"> <li>1. Inconsistent aging levels of battery cells</li> <li>2. Issues with the board chip can also lead to excessive voltage differences between battery cells.</li> <li>3. Cell imbalance issues can also lead to excessive voltage differences between cells.</li> <li>4. Harness issue causing</li> </ol>	Shut down, restart Battery, and wait for 2 hours. If the issue persists, contact the after-sales service center.

No.	fault name	fault cause	Troubleshooting Recommendation
33	BMS1 Cluster 1 Relay or MOS Short Circuit fault BMS1 RACK1 Relay or MOS short-circuit fault	MOS short circuit	1. Upgrade the software, power off and let it sit for 5 minutes, then check if fault persists after restarting. 2. If the issue persists, contact the after-sales service center.
34	BMS1 Cluster 1 relay or MOS open circuit fault/ BMS1 RACK1 Relay or MOS open-circuit fault	MOS open circuit	1. Upgrade the software, power off and let it sit for 5 minutes, then check if fault persists after restarting. 2. If the issue persists, contact the after-sales service center.
35	BMS1 Cluster 1Pre-charging Failurefault/ BMS1 RACK1 The precharge failed fault	The voltage across the precharge MOS voltage consistently exceeds the specified threshold.	1. Upgrade the software, power off and let it stand for 5 minutes, then check if fault persists after restarting. 2. If the issue persists, contact the after-sales service center.

No.	fault name	fault cause	Troubleshooting Recommendation
36	BMS1 Cluster 1 Acquisition Line fault/ BMS1 RACK1 Acquisition line fault	Battery acquisition line poor contact or disconnected	Power off, check the wiring, re-stack the Battery, and restart. If the issue persists, please contact the after-sales service center.
37	BMS1 Cluster 1 relay or MOS temperature too high fault BMS1 RACK1 Relay or MOS temperature is too high fault	Relay or MOSFET overtemperature	<ol style="list-style-type: none"> <li>1. Upgrade the software, power off and let it stand for 30 minutes, then check if fault persists after restarting.</li> <li>2. If the issue persists, contact the after-sales service center.</li> </ol>
38	BMS1 Cluster 1 Shunt Over-temperaturefault/ BMS1 RACK1 Diverter temperature is too high fault	Shunt Over-temperature	<ol style="list-style-type: none"> <li>1. Upgrade the software, power off and let it sit for 30 minutes, then restart to check if fault persists.</li> <li>2. If the issue persists, contact the after-sales service center.</li> </ol>
39	BMS1 Cluster 1 Communication from MCU fault BMS1 RACK1 Slave MCU communication fault	Communication loss between master and slave chips	<ol style="list-style-type: none"> <li>1. Check the wiring and restart the Battery.</li> <li>2. Upgrade the Battery. If the issue persists after restarting, please contact the after-sales service center.</li> </ol>

No.	fault name	fault cause	Troubleshooting Recommendation
40	BMS1 Cluster 1 BMU Communication fault/ BMS1 RACK1 BMU communication fault	Abnormal communication harness between BMS master and slave control	Check the wiring and restart the Battery. 2. Upgrade the Battery. If the problem persists after restarting, please contact the after-sales service center.
41	BMS1 Cluster 1 Microelectronics fault/ BMS1 RACK1 Micro-electronics fault	Internal fault of MCU	Upgrade the software and restart the Battery. If the issue persists after restarting, please contact the after-sales service center.
42	BMS1 Cluster 1 Hardware Overcurrent fault/ BMS1 RACK1 Hardware overcurrent fault	<ol style="list-style-type: none"> <li>1. The software version is too low or the BMS board is damaged.</li> <li>2. The number of parallel units is large, and the impact during pre-charging is excessive.</li> </ol>	<p>Upgrade the software and observe whether fault persists.</p> <ol style="list-style-type: none"> <li>2. In the case of parallel operation, perform a black start on Battery first, then start Inverter.</li> </ol>
43	BMS1 Cluster 1 Application Software Failure/ BMS1 RACK1 Application software fault	MCU self-test failed	Upgrade the software and restart the Battery. If the issue persists after restarting, please contact the after-sales service center.

No.	fault name	fault cause	Troubleshooting Recommendation
44	BMS1 parallel cluster 1 parallel cluster fault/ BMS1 RACK1 Parallel RACK fault	Communication abnormality between the master cluster and slave cluster, or inconsistency of battery cells between clusters.	<ol style="list-style-type: none"> <li>1. Check the Battery information and software version of the slave unit, and verify whether the communication cable connection with the master unit is normal.</li> <li>2. Upgrade software</li> </ol>
45	BMS1 Cluster 1 DCDC Failure/ BMS1 RACK1 DCDC fault	DCDCOverload or excessive heat sink temperature	Upgrade the software and restart the Battery. If the issue persists after restarting, please contact the after-sales service center.
46	BMS1 cluster 1 cell inconsistency fault BMS1 RACK1 Inconsistent cell fault	<ol style="list-style-type: none"> <li>1. Abnormal Cell Identification</li> <li>2. Stacking of different types of battery cells</li> </ol>	Check Cell Type
47	BMS1 Cluster 1 Output port Overtemperature fault/ BMS1 RACK1 The output port over temperature fault	Output port screw loose or poor contact	<ol style="list-style-type: none"> <li>1. Battery Shut down, check wiring and output port screw status</li> <li>2. After confirmation, restart the Battery and observe whether the fault persists. If it does, contact the after-sales service center.</li> </ol>

No.	fault name	fault cause	Troubleshooting Recommendation
48	BMS1 Cluster 1 SOH Too Lowfault/ BMS1 RACK1 SOH too low fault	Battery has been used for too long or the battery cell is severely damaged.	Replace pack
49	BMS1 Cluster 1 Heating Film Three-Terminal fault BMS1 RACK1 Heating film MOS Three-terminal fault	Heating film MOS damage	Please contact the after-sales service center.

# 9 technical parameter

## 9.1 Inverter Parameters

Technical Data	GW5K-ETA-G20	GW6K-ETA-G20	GW8K-ETA-G20
Battery Side			
Battery Type	LFP (LiFePO <sub>4</sub> )	LFP (LiFePO <sub>4</sub> )	LFP (LiFePO <sub>4</sub> )
Nominal Voltage (V)	750	750	750
Voltage Range (V)	700~950	700~950	700~950
Start-up Voltage (V)	720	720	720
Number of Battery Input	1	1	1
Max. Continuous Charging Current (A)	6.7	8.1	10.7
Max. Continuous Discharging Current (A)	7.4	8.9	11.8
Max. Charging Power (kW)	5	6	8
Max. Discharging Power (kW)	5.5	6.6	8.8
PV Side			
Max. Input Power (kW)	10	12	16

<b>Technical Data</b>	<b>GW5K-ETA-G20</b>	<b>GW6K-ETA-G20</b>	<b>GW8K-ETA-G20</b>
Max. Input Voltage (V) <sup>*1</sup>	1000	1000	1000
MPPT Operating Voltage Range (V) <sup>*2</sup>	120~950	120~950	120~950
MPPT Voltage Range at Nominal Power (V)	185~850	225~850	300~850
Start-up Voltage (V)	150	150	150
Nominal Input Voltage (V)	750	750	750
Max. MPPT Current (A)	21/21/21	21/21/21	21/21/21
Max. MPPT Short Circuit Current (A)	26/26/26	26/26/26	26/26/26
Max. Backfeed Current to The Array (A)	0	0	0
Number of MPPTs	3	3	3
Number of Strings per MPPT	1/1/1	1/1/1	1/1/1
<b>AC Side (Grid Port)</b>			
Rated Power (kW)	5	6	8
Max. Power (kW)	5	6	8
Rated Apparent Power to Grid (kVA)	5	6	8

Technical Data	GW5K-ETA-G20	GW6K-ETA-G20	GW8K-ETA-G20
Rated Apparent Power from Grid (kVA)	5	6	8
Max. Apparent Power to Grid (kVA) <sup>*3</sup>	5	6	8
Max. Apparent Power from Grid (kVA)	43.5 <sup>*4</sup>	43.5 <sup>*4</sup>	43.5 <sup>*4</sup>
Nominal Voltage (V)	220/380, 230/400, 3L/N/PE	220/380, 230/400, 3L/N/PE	220/380, 230/400, 3L/N/PE
Voltage Range (V)	180 ~ 260 (According to local standard)	180 ~ 260 (According to local standard)	180 ~ 260 (According to local standard)
Nominal Frequency (Hz)	50/60	50/60	50/60
Frequency Range (Hz)	45~55 / 55~65	45~55 / 55~65	45~55 / 55~65
Rated Current to Grid (A)	7.6 @380V 7.3 @400V	9.1 @380V 8.7 @400V	12.2 @380V 11.6 @400V
Rated Current from Grid (A)	7.6 @380V 7.3 @400V	9.1 @380V 8.7 @400V	12.2 @380V 11.6 @400V
Max. Current to Grid (A) <sup>*6</sup>	7.6 @380V 7.3 @400V	9.1 @380V 8.7 @400V	12.2 @380V 11.6 @400V
Max. Current from Grid (A) <sup>*6</sup>	63.0 <sup>*4</sup>	63.0 <sup>*4</sup>	63.0 <sup>*4</sup>
Max. Output Fault Current (Peak and Duration) (A)	46.7@4μs	46.7@4μs	46.7@4μs

Technical Data	GW5K-ETA-G20	GW6K-ETA-G20	GW8K-ETA-G20
Inrush Current (Peak and Duration) (A)	21.3@5ms	21.3@5ms	21.3@5ms
THDi	<3%	<3%	<3%
Maximum Output Overcurrent Protection (A)	46.7	46.7	46.7
Type of Voltage	a.c.	a.c.	a.c.
AC Side (Back-up Port)			
Rated Apparent Power (kVA)	5	6	8
Max. Apparent Power (kVA) <sup>*7</sup>	Off-grid: 5.5 (10.0, 10s), on-grid: 43.5	Off-grid: 6.6(12, 10s), on-grid: 43.5	Off-grid: 8.8 (16.0, 10s), on-grid: 43.5
Nominal Voltage (V)	220/380, 230/400, 3L/N/PE	220/380, 230/400, 3L/N/PE	220/380, 230/400, 3L/N/PE
Nominal Frequency (Hz)	50/60	50/60	50/60
Frequency Range (Hz)	45~55 / 55~65	45~55 / 55~65	45~55 / 55~65
Rated Current (A)	7.6 @380V 7.3 @400V	9.1 @380V 8.7 @400V	12.2 @380V 11.6 @400V
Max. Current (A) <sup>*7</sup>	Off-grid: 11.4, on-grid: 63	Off-grid: 13.7, on-grid:63	Off-grid: 18.2, on-grid: 63
Max. Fault Current (Peak and Duration) (A)	46.7@4μs	46.7@4μs	46.7@4μs

<b>Technical Data</b>	<b>GW5K-ETA-G20</b>	<b>GW6K-ETA-G20</b>	<b>GW8K-ETA-G20</b>
Inrush Current (Peak and Duration) (A)	21.3@5ms	21.3@5ms	21.3@5ms
Maximum Overcurrent Protection (A)	46.7	46.7	46.7
THDv (@Linear Load)	<3%	<3%	<3%
On/Off-grid Switching Time (ms)	<4	<4	<4
<b>Efficiency</b>			
Max. Efficiency	98.00%	98.00%	98.00%
European Efficiency	96.40%	96.90%	97.10%
Max. Battery to AC Efficiency	98.00%	98.00%	98.00%
<b>Protection</b>			
PV String Current Monitoring	Integrated	Integrated	Integrated
PV Insulation Resistance Detection	Integrated	Integrated	Integrated
Residual Current Monitoring	Integrated	Integrated	Integrated
PV Reverse Polarity Protection	Integrated	Integrated	Integrated

<b>Technical Data</b>	<b>GW5K-ETA-G20</b>	<b>GW6K-ETA-G20</b>	<b>GW8K-ETA-G20</b>
Battery Reverse Polarity Protection	Integrated	Integrated	Integrated
Anti-islanding Protection	Integrated	Integrated	Integrated
AC Overcurrent Protection	Integrated	Integrated	Integrated
AC Short Circuit Protection	Integrated	Integrated	Integrated
AC Overvoltage Protection	Integrated	Integrated	Integrated
DC Switch	Integrated	Integrated	Integrated
DC Surge Protection	Type II(Type I+II optional)	Type II(Type I+II optional)	Type II(Type I+II optional)
AC Surge Protection	Type II	Type II	Type II
Rapid Shutdown	Optional	Optional	Optional
AFCI	Optional	Optional	Optional
Remote Shutdown	Integrated	Integrated	Integrated
<b>General Data</b>			
Power Factor	0.8 leading ... 0.8 lagging	0.8 leading ... 0.8 lagging	0.8 leading ... 0.8 lagging
Operating Temperature Range (°C)	-35~+60	-35~+60	-35~+60
Operating Environment	Indoor/Outdoor	Indoor/Outdoor	Indoor/Outdoor

<b>Technical Data</b>	<b>GW5K-ETA-G20</b>	<b>GW6K-ETA-G20</b>	<b>GW8K-ETA-G20</b>
Relative Humidity	0~100%	0~100%	0~100%
Max. Operating Altitude (m)	4000 (>2000 derating)	4000 (>2000 derating)	4000 (>2000 derating)
Cooling Method	Smart Fan Cooling	Smart Fan Cooling	Smart Fan Cooling
User Interface	LED, WLAN+APP	LED, WLAN+APP	LED, WLAN+APP
Communication with BMS	CAN	CAN	CAN
Communication	RS485, WiFi+LAN+Bluetooth, 4G+Bluetooth(Optional)	RS485, WiFi+LAN+Bluetooth, 4G+Bluetooth(Optional)	RS485, WiFi+LAN+Bluetooth, 4G+Bluetooth(Optional)
Communication Protocols	Modbus-RTU, Modbus-TCP	Modbus-RTU, Modbus-TCP	Modbus-RTU, Modbus-TCP
Weight (kg)	34	34	34
Dimension (W×H×D mm)	800*340*270	800*340*270	800*340*270
Noise Emission (dB)	≤35	≤35	≤35
Topology	Non-isolated	Non-isolated	Non-isolated
Self-consumption at Night (W)	≤10	≤10	≤10
Ingress Protection Rating	IP66	IP66	IP66
DC Connector	MC4, VACONN Terminal	MC4, VACONN Terminal	MC4, VACONN Terminal

<b>Technical Data</b>	<b>GW5K-ETA-G20</b>	<b>GW6K-ETA-G20</b>	<b>GW8K-ETA-G20</b>
AC Connector	VACONN Terminal	VACONN Terminal	VACONN Terminal
Environmental Category	4K4H	4K4H	4K4H
Pollution Degree	III	III	III
Overvoltage Category	DC II / AC III	DC II / AC III	DC II / AC III
Protective Class	I	I	I
Storage Temperature (°C)	-40~+70	-40~+70	-40~+70
The Decisive Voltage Class (DVC)	Battery: C PV: C AC: C Com: A	Battery: C PV: C AC: C Com: A	Battery: C PV: C AC: C Com: A
Mounting Method	Wall/Floor Mounted	Wall/Floor Mounted	Wall/Floor Mounted
Active Anti-islanding Method <sup>*8</sup>	SMS(Slip-mode frequency) +AFD	SMS(Slip-mode frequency) +AFD	SMS(Slip-mode frequency) +AFD
Type of Electrical Supply System	three phase	three phase	three phase
Country of Manufacture	China	China	China
Certification			
Grid Standard	Please refer to the official website		
Safety Regulation			

Technical Data	GW5K-ETA-G20	GW6K-ETA-G20	GW8K-ETA-G20
EMC			

Technical Data	GW9.999K-ETA-G20	GW10K-ETA-G20	GW12K-ETA-G20
Battery Side			
Battery Type	LFP (LiFePO <sub>4</sub> )	LFP (LiFePO <sub>4</sub> )	LFP (LiFePO <sub>4</sub> )
Nominal Voltage (V)	750	750	750
Voltage Range (V)	700~950	700~950	700~950
Start-up Voltage (V)	720	720	720
Number of Battery Input	1	1	1
Max. Continuous Charging Current (A)	13.4	13.4	16.1
Max. Continuous Discharging Current (A)	14.7	14.7	17.7
Max. Charging Power (kW)	10	10	12
Max. Discharging Power (kW)	11	11	13.2
PV Side			
Max. Input Power (kW)	20	20	24

<b>Technical Data</b>	<b>GW9.999K-ETA-G20</b>	<b>GW10K-ETA-G20</b>	<b>GW12K-ETA-G20</b>
Max. Input Voltage (V) <sup>*1</sup>	1000	1000	1000
MPPT Operating Voltage Range (V) <sup>*2</sup>	120~950	120~950	120~950
MPPT Voltage Range at Nominal Power (V)	250~850	250~850	300~850
Start-up Voltage (V)	150	150	150
Nominal Input Voltage (V)	750	750	750
Max. MPPT Current (A)	21/21/21/21	21/21/21/21	21/21/21/21
Max. MPPT Short Circuit Current (A)	26/26/26/26	26/26/26/26	26/26/26/26
Max. Backfeed Current to The Array (A)	0	0	0
Number of MPPTs	4	4	4
Number of Strings per MPPT	1/1/1/1	1/1/1/1	1/1/1/1
<b>AC Side (Grid Port)</b>			
Rated Power (kW)	9.999	10	12
Max. Power (kW)	9.999	10	12
Rated Apparent Power to Grid (kVA)	9.999	10	12

Technical Data	GW9.999K-ETA-G20	GW10K-ETA-G20	GW12K-ETA-G20
Rated Apparent Power from Grid (kVA)	9.999	10	12
Max. Apparent Power to Grid (kVA) <sup>*3</sup>	9.999	10	12
Max. Apparent Power from Grid (kVA)	43.5 <sup>*4</sup>	43.5 <sup>*4</sup>	43.5 <sup>*4</sup>
Nominal Voltage (V)	220/380, 230/400, 3L/N/PE	220/380, 230/400, 3L/N/PE	220/380, 230/400, 3L/N/PE
Voltage Range (V)	180 ~ 260 (According to local standard)	180 ~ 260 (According to local standard)	180 ~ 260 (According to local standard)
Nominal Frequency (Hz)	50/60	50/60	50/60
Frequency Range (Hz)	45~55 / 55~65	45~55 / 55~65	45~55 / 55~65
Rated Current to Grid (A)	15.2 @380V 14.5 @400V	15.2 @380V 14.5 @400V	18.2 @380V 17.4 @400V
Rated Current from Grid (A)	15.2 @380V 14.5 @400V	15.2 @380V 14.5 @400V	18.2 @380V 17.4 @400V
Max. Current to Grid (A) <sup>*6</sup>	15.2 @380V 14.5 @400V	15.2 @380V 14.5 @400V	18.2 @380V 17.4 @400V
Max. Current from Grid (A) <sup>*6</sup>	63.0 <sup>*4</sup>	63.0 <sup>*4</sup>	63.0 <sup>*4</sup>
Max. Output Fault Current (Peak and Duration) (A)	74.6@4μs	74.6@4μs	74.6@4μs

Technical Data	GW9.999K-ETA-G20	GW10K-ETA-G20	GW12K-ETA-G20
Inrush Current (Peak and Duration) (A)	25.4@5ms	25.4@5ms	25.4@5ms
THDi	<3%	<3%	<3%
Maximum Output Overcurrent Protection (A)	74.6	74.6	74.6
Type of Voltage	a.c.	a.c.	a.c.
AC Side (Back-up Port)			
Rated Apparent Power (kVA)	10	10	12
Max. Apparent Power (kVA)*7	Off-grid: 11(20.0, 10s), on-grid: 43.5	Off-grid: 11(20.0, 10s), on-grid: 43.5	Off-grid: 13.2(24, 10s), on-grid: 43.5
Nominal Voltage (V)	220/380, 230/400, 3L/N/PE	220/380, 230/400, 3L/N/PE	220/380, 230/400, 3L/N/PE
Nominal Frequency (Hz)	50/60	50/60	50/60
Frequency Range (Hz)	45~55 / 55~65	45~55 / 55~65	45~55 / 55~65
Rated Current (A)	15.2 @380V 14.5 @400V	15.2 @380V 14.5 @400V	18.2 @380V 17.4 @400V
Max. Current (A)*7	Off-grid: 22.8, on-grid:63	Off-grid: 22.8, on-grid: 63	Off-grid: 27.3, on-grid: 63
Max. Fault Current (Peak and Duration) (A)	74.6@4μs	74.6@4μs	74.6@4μs

<b>Technical Data</b>	<b>GW9.999K-ETA-G20</b>	<b>GW10K-ETA-G20</b>	<b>GW12K-ETA-G20</b>
Inrush Current (Peak and Duration) (A)	25.4@5ms	25.4@5ms	25.4@5ms
Maximum Overcurrent Protection (A)	74.6	74.6	74.6
THDv (@Linear Load)	<3%	<3%	<3%
On/Off-grid Switching Time (ms)	<4	<4	<4
<b>Efficiency</b>			
Max. Efficiency	98.10%	98.10%	98.10%
European Efficiency	97.20%	97.20%	97.20%
Max. Battery to AC Efficiency	98.00%	98.00%	98.00%
<b>Protection</b>			
PV String Current Monitoring	Integrated	Integrated	Integrated
PV Insulation Resistance Detection	Integrated	Integrated	Integrated
Residual Current Monitoring	Integrated	Integrated	Integrated
PV Reverse Polarity Protection	Integrated	Integrated	Integrated

<b>Technical Data</b>	<b>GW9.999K-ETA-G20</b>	<b>GW10K-ETA-G20</b>	<b>GW12K-ETA-G20</b>
Battery Reverse Polarity Protection	Integrated	Integrated	Integrated
Anti-islanding Protection	Integrated	Integrated	Integrated
AC Overcurrent Protection	Integrated	Integrated	Integrated
AC Short Circuit Protection	Integrated	Integrated	Integrated
AC Overvoltage Protection	Integrated	Integrated	Integrated
DC Switch	Integrated	Integrated	Integrated
DC Surge Protection	Type II(Type I+II optional)	Type II(Type I+II optional)	Type II(Type I+II optional)
AC Surge Protection	Type II	Type II	Type II
Rapid Shutdown	Optional	Optional	Optional
AFCI	Optional	Optional	Optional
Remote Shutdown	Integrated	Integrated	Integrated
<b>General Data</b>			
Power Factor	0.8 leading ... 0.8 lagging	0.8 leading ... 0.8 lagging	0.8 leading ... 0.8 lagging
Operating Temperature Range (°C)	-35~+60	-35~+60	-35~+60

<b>Technical Data</b>	<b>GW9.999K-ETA-G20</b>	<b>GW10K-ETA-G20</b>	<b>GW12K-ETA-G20</b>
Operating Environment	Indoor/Outdoor	Indoor/Outdoor	Indoor/Outdoor
Relative Humidity	0~100%	0~100%	0~100%
Max. Operating Altitude (m)	4000 (>2000 derating)	4000 (>2000 derating)	4000 (>2000 derating)
Cooling Method	Smart Fan Cooling	Smart Fan Cooling	Smart Fan Cooling
User Interface	LED, WLAN+APP	LED, WLAN+APP	LED, WLAN+APP
Communication with BMS	CAN	CAN	CAN
Communication	RS485, WiFi+LAN+Bluetooth, 4G+Bluetooth(Optional)	RS485, WiFi+LAN+Bluetooth, 4G+Bluetooth(Optional)	RS485, WiFi+LAN+Bluetooth, 4G+Bluetooth(Optional)
Communication Protocols	Modbus-RTU, Modbus-TCP	Modbus-RTU, Modbus-TCP	Modbus-RTU, Modbus-TCP
Weight (kg)	34	34	34
Dimension (W×H×D mm)	800*340*270	800*340*270	800*340*270
Noise Emission (dB)	≤40	≤40	≤40
Topology	Non-isolated	Non-isolated	Non-isolated
Self-consumption at Night (W)	≤10	≤10	≤10
Ingress Protection Rating	IP66	IP66	IP66

<b>Technical Data</b>	<b>GW9.999K-ETA-G20</b>	<b>GW10K-ETA-G20</b>	<b>GW12K-ETA-G20</b>
DC Connector	MC4, VACONN Terminal	MC4, VACONN Terminal	MC4, VACONN Terminal
AC Connector	VACONN Terminal	VACONN Terminal	VACONN Terminal
Environmental Category	4K4H	4K4H	4K4H
Pollution Degree	III	III	III
Overvoltage Category	DC II / AC III	DC II / AC III	DC II / AC III
Protective Class	I	I	I
Storage Temperature (°C)	-40~+70	-40~+70	-40~+70
The Decisive Voltage Class (DVC)	Battery: C PV: C AC: C Com: A	Battery: C PV: C AC: C Com: A	Battery: C PV: C AC: C Com: A
Mounting Method	Wall/Floor Mounted	Wall/Floor Mounted	Wall/Floor Mounted
Active Anti-islanding Method <sup>*8</sup>	SMS(Slip-mode frequency) +AFD	SMS(Slip-mode frequency) +AFD	SMS(Slip-mode frequency) +AFD
Type of Electrical Supply System	three phase	three phase	three phase
Country of Manufacture	China	China	China
Certification			

Technical Data	GW9.999K-ETA-G20	GW10K-ETA-G20	GW12K-ETA-G20
Grid Standard	Please refer to the official website		
Safety Regulation			
EMC			

Technical Data	GW15K-ETA-G20	GW20K-ETA-G20	GW25K-ETA-G20
Battery Side			
Battery Type	LFP (LiFePO <sub>4</sub> )	LFP (LiFePO <sub>4</sub> )	LFP (LiFePO <sub>4</sub> )
Nominal Voltage (V)	750	750	750
Voltage Range (V)	700~950	700~950	700~950
Start-up Voltage (V)	720	720	720
Number of Battery Input	1	1	1
Max. Continuous Charging Current (A)	20.1	26.7	33.3
Max. Continuous Discharging Current (A)	22.1	29.4	36.7
Max. Charging Power (kW)	15	20	25
Max. Discharging Power (kW)	16.5	22	27.5
PV Side			

<b>Technical Data</b>	<b>GW15K-ETA-G20</b>	<b>GW20K-ETA-G20</b>	<b>GW25K-ETA-G20</b>
Max. Input Power (kW)	30	40	50
Max. Input Voltage (V) <sup>*1</sup>	1000	1000	1000
MPPT Operating Voltage Range (V) <sup>*2</sup>	120~950	120~950	120~950
MPPT Voltage Range at Nominal Power (V)	360~850	400~850	400~850
Start-up Voltage (V)	150	150	150
Nominal Input Voltage (V)	750	750	750
Max. MPPT Current (A)	21/21/21/21	21/21/21/21	21/21/42/42
Max. MPPT Short Circuit Current (A)	26/26/26/26	26/26/26/26	26/26/52/52
Max. Backfeed Current to The Array (A)	0	0	0
Number of MPPTs	4	4	4
Number of Strings per MPPT	1/1/1/1	1/1/1/1	1/1/2/2
AC Side (Grid Port)			
Rated Power (kW)	15	20	25
Max. Power (kW)	15	20	25

Technical Data	GW15K-ETA-G20	GW20K-ETA-G20	GW25K-ETA-G20
Rated Apparent Power to Grid (kVA)	15	20	25
Rated Apparent Power from Grid (kVA)	15	20	25
Max. Apparent Power to Grid (kVA) <sup>*3</sup>	15	20	25
Max. Apparent Power from Grid (kVA)	43.5 <sup>*4</sup>	43.5 <sup>*4</sup>	55.2 <sup>*5</sup>
Nominal Voltage (V)	220/380, 230/400, 3L/N/PE	220/380, 230/400, 3L/N/PE	220/380, 230/400, 3L/N/PE
Voltage Range (V)	180 ~ 260 (According to local standard)	180 ~ 260 (According to local standard)	180 ~ 260 (According to local standard)
Nominal Frequency (Hz)	50/60	50/60	50/60
Frequency Range (Hz)	45~55 / 55~65	45~55 / 55~65	45~55 / 55~65
Rated Current to Grid (A)	22.8 @380V 21.8 @400V	30.4 @380V 29.0 @400V	37.9 @380V 36.3 @400V
Rated Current from Grid (A)	22.8 @380V 21.8 @400V	30.4 @380V 29.0 @400V	37.9 @380V 36.3 @400V
Max. Current to Grid (A) <sup>*6</sup>	22.8 @380V 21.8 @400V	30.4 @380V 29.0 @400V	37.9 @380V 36.3 @400V
Max. Current from Grid (A) <sup>*6</sup>	63.0 <sup>*4</sup>	63.0 <sup>*4</sup>	80.0 <sup>*5</sup>

Technical Data	GW15K-ETA-G20	GW20K-ETA-G20	GW25K-ETA-G20
Max. Output Fault Current (Peak and Duration) (A)	83.3@4μs	83.3@4μs	125@4μs
Inrush Current (Peak and Duration) (A)	29.1@5ms	29.1@5ms	32.3@5ms
THDi	<3%	<3%	<3%
Maximum Output Overcurrent Protection (A)	83.3	83.3	125
Type of Voltage	a.c.	a.c.	a.c.
AC Side (Back-up Port)			
Rated Apparent Power (kVA)	15	20	25
Max. Apparent Power (kVA) <sup>*7</sup>	Off-grid: 16.5(30, 10s), on-grid:43.5	Off-grid: 22(30.0, 10s), on-grid:43.5	Off-grid: 27.5(45.0, 10s), on-grid:55.2
Nominal Voltage (V)	220/380, 230/400, 3L/N/PE	220/380, 230/400, 3L/N/PE	220/380, 230/400, 3L/N/PE
Nominal Frequency (Hz)	50/60	50/60	50/60
Frequency Range (Hz)	45~55 / 55~65	45~55 / 55~65	45~55 / 55~65
Rated Current (A)	22.8 @380V 21.8 @400V	30.4 @380V 29.0 @400V	37.9 @380V 36.3 @400V
Max. Current (A) <sup>*7</sup>	Off-grid: 33.4, on-grid: 63	Off-grid: 33.4, on-grid: 63	Off-grid: 50.0, on-grid: 80

<b>Technical Data</b>	<b>GW15K-ETA-G20</b>	<b>GW20K-ETA-G20</b>	<b>GW25K-ETA-G20</b>
Max. Fault Current (Peak and Duration) (A)	83.3@4μs	83.3@4μs	125@4μs
Inrush Current (Peak and Duration) (A)	29.1@5ms	29.1@5ms	32.3@5ms
Maximum Overcurrent Protection (A)	83.3	83.3	125
THDv (@Linear Load)	<3%	<3%	<3%
On/Off-grid Switching Time (ms)	<4	<4	<4
Efficiency			
Max. Efficiency	98.10%	98.10%	98.20%
European Efficiency	97.30%	97.30%	97.40%
Max. Battery to AC Efficiency	98.00%	98.00%	98.00%
Protection			
PV String Current Monitoring	Integrated	Integrated	Integrated
PV Insulation Resistance Detection	Integrated	Integrated	Integrated
Residual Current Monitoring	Integrated	Integrated	Integrated

<b>Technical Data</b>	<b>GW15K-ETA-G20</b>	<b>GW20K-ETA-G20</b>	<b>GW25K-ETA-G20</b>
PV Reverse Polarity Protection	Integrated	Integrated	Integrated
Battery Reverse Polarity Protection	Integrated	Integrated	Integrated
Anti-islanding Protection	Integrated	Integrated	Integrated
AC Overcurrent Protection	Integrated	Integrated	Integrated
AC Short Circuit Protection	Integrated	Integrated	Integrated
AC Overvoltage Protection	Integrated	Integrated	Integrated
DC Switch	Integrated	Integrated	Integrated
DC Surge Protection	Type II(Type I+II optional)	Type II(Type I+II optional)	Type II(Type I+II optional)
AC Surge Protection	Type II	Type II	Type II
Rapid Shutdown	Optional	Optional	Optional
AFCI	Optional	Optional	Optional
Remote Shutdown	Integrated	Integrated	Integrated
<b>General Data</b>			
Power Factor	0.8 leading ... 0.8 lagging	0.8 leading ... 0.8 lagging	0.8 leading ... 0.8 lagging
Operating Temperature Range (°C)	-35~+60	-35~+60	-35~+60

<b>Technical Data</b>	<b>GW15K-ETA-G20</b>	<b>GW20K-ETA-G20</b>	<b>GW25K-ETA-G20</b>
Operating Environment	Indoor/Outdoor	Indoor/Outdoor	Indoor/Outdoor
Relative Humidity	0~100%	0~100%	0~100%
Max. Operating Altitude (m)	4000 (>2000 derating)	4000 (>2000 derating)	4000 (>2000 derating)
Cooling Method	Smart Fan Cooling	Smart Fan Cooling	Smart Fan Cooling
User Interface	LED, WLAN+APP	LED, WLAN+APP	LED, WLAN+APP
Communication with BMS	CAN	CAN	CAN
Communication	RS485, WiFi+LAN+Bluetooth, 4G+Bluetooth(Optional)	RS485, WiFi+LAN+Bluetooth, 4G+Bluetooth(Optional)	RS485, WiFi+LAN+Bluetooth, 4G+Bluetooth(Optional)
Communication Protocols	Modbus-RTU, Modbus-TCP	Modbus-RTU, Modbus-TCP	Modbus-RTU, Modbus-TCP
Weight (kg)	34	34	38
Dimension (W×H×D mm)	800*340*270	800*340*270	800*340*270
Noise Emission (dB)	≤40	≤40	≤45
Topology	Non-isolated	Non-isolated	Non-isolated
Self-consumption at Night (W)	≤10	≤10	≤10
Ingress Protection Rating	IP66	IP66	IP66

<b>Technical Data</b>	<b>GW15K-ETA-G20</b>	<b>GW20K-ETA-G20</b>	<b>GW25K-ETA-G20</b>
DC Connector	MC4, VACONN Terminal	MC4, VACONN Terminal	MC4, VACONN Terminal
AC Connector	VACONN Terminal	VACONN Terminal	VACONN Terminal
Environmental Category	4K4H	4K4H	4K4H
Pollution Degree	III	III	III
Overvoltage Category	DC II / AC III	DC II / AC III	DC II / AC III
Protective Class	I	I	I
Storage Temperature (°C)	-40~+70	-40~+70	-40~+70
The Decisive Voltage Class (DVC)	Battery: C PV: C AC: C Com: A	Battery: C PV: C AC: C Com: A	Battery: C PV: C AC: C Com: A
Mounting Method	Wall/Floor Mounted	Wall/Floor Mounted	Wall/Floor Mounted
Active Anti-islanding Method*8	SMS(Slip-mode frequency) +AFD	SMS(Slip-mode frequency) +AFD	SMS(Slip-mode frequency) +AFD
Type of Electrical Supply System	three phase	three phase	three phase
Country of Manufacture	China	China	China
Certification			
Grid Standard			

Technical Data	GW15K-ETA-G20	GW20K-ETA-G20	GW25K-ETA-G20
Safety Regulation	Please refer to the official website		
EMC			

Technical Data	GW29.999K-ETA-G20	GW30K-ETA-G20
Battery Side		
Battery Type	LFP (LiFePO <sub>4</sub> )	LFP (LiFePO <sub>4</sub> )
Nominal Voltage (V)	750	750
Voltage Range (V)	700~950	700~950
Start-up Voltage (V)	720	720
Number of Battery Input	1	1
Max. Continuous Charging Current (A)	40.0	40.0
Max. Continuous Discharging Current (A)	44.1	44.1
Max. Charging Power (kW)	30	30
Max. Discharging Power (kW)	33	33
PV Side		
Max. Input Power (kW)	60	60
Max. Input Voltage (V) <sup>*1</sup>	1000	1000
MPPT Operating Voltage Range (V) <sup>*2</sup>	120~950	120~950

<b>Technical Data</b>	<b>GW29.999K-ETA-G20</b>	<b>GW30K-ETA-G20</b>
MPPT Voltage Range at Nominal Power (V)	450~850	450~850
Start-up Voltage (V)	150	150
Nominal Input Voltage (V)	750	750
Max. MPPT Current (A)	21/21/42/42	21/21/42/42
Max. MPPT Short Circuit Current (A)	26/26/52/52	26/26/52/52
Max. Backfeed Current to The Array (A)	0	0
Number of MPPTs	4	4
Number of Strings per MPPT	1/1/2/2	1/1/2/2
AC Side (Grid Port)		
Rated Power (kW)	29.999	30
Max. Power (kW)	29.999	30
Rated Apparent Power to Grid (kVA)	29.999	30
Rated Apparent Power from Grid (kVA)	29.999	30
Max. Apparent Power to Grid (kVA) <sup>*3</sup>	29.999	30
Max. Apparent Power from Grid (kVA)	55.2 <sup>*5</sup>	55.2 <sup>*5</sup>
Nominal Voltage (V)	220/380, 230/400, 3L/N/PE	220/380, 230/400, 3L/N/PE

<b>Technical Data</b>	<b>GW29.999K-ETA-G20</b>	<b>GW30K-ETA-G20</b>
Voltage Range (V)	180 ~ 260 (According to local standard)	180 ~ 260 (According to local standard)
Nominal Frequency (Hz)	50/60	50/60
Frequency Range (Hz)	45~55 / 55~65	45~55 / 55~65
Rated Current to Grid (A)	45.5 @380V 43.5 @400V	45.5 @380V 43.5 @400V
Rated Current from Grid (A)	45.5 @380V 43.5 @400V	45.5 @380V 43.5 @400V
Max. Current to Grid (A)*6	45.5 @380V 43.5 @400V	45.5 @380V 43.5 @400V
Max. Current from Grid (A)*6	80.0*5	80.0*5
Max. Output Fault Current (Peak and Duration) (A)	125@4μs	125@4μs
Inrush Current (Peak and Duration) (A)	32.3@5ms	32.3@5ms
THDi	<3%	<3%
Maximum Output Overcurrent Protection (A)	125	125
Type of Voltage	a.c.	a.c.
AC Side (Back-up Port)		
Rated Apparent Power (kVA)	30	30
Max. Apparent Power (kVA)*7	Off-grid: 33(45.0, 10s), on-grid: 55.2	Off-grid: 33(45.0, 10s), on-grid:55.2

<b>Technical Data</b>	<b>GW29.999K-ETA-G20</b>	<b>GW30K-ETA-G20</b>
Nominal Voltage (V)	220/380, 230/400, 3L/N/PE	220/380, 230/400, 3L/N/PE
Nominal Frequency (Hz)	50/60	50/60
Frequency Range (Hz)	45~55 / 55~65	45~55 / 55~65
Rated Current (A)	45.5 @380V 43.5 @400V	45.5 @380V 43.5 @400V
Max. Current (A)*7	Off-grid: 50.0, on-grid: 80	Off-grid: 50.0, on-grid: 80
Max. Fault Current (Peak and Duration) (A)	125@4 $\mu$ s	125@4 $\mu$ s
Inrush Current (Peak and Duration) (A)	32.3@5ms	32.3@5ms
Maximum Overcurrent Protection (A)	125	125
THDv (@Linear Load)	<3%	<3%
On/Off-grid Switching Time (ms)	<4	<4
Efficiency		
Max. Efficiency	98.20%	98.20%
European Efficiency	97.40%	97.40%
Max. Battery to AC Efficiency	98.00%	98.00%
Protection		
PV String Current Monitoring	Integrated	Integrated

<b>Technical Data</b>	<b>GW29.999K-ETA-G20</b>	<b>GW30K-ETA-G20</b>
PV Insulation Resistance Detection	Integrated	Integrated
Residual Current Monitoring	Integrated	Integrated
PV Reverse Polarity Protection	Integrated	Integrated
Battery Reverse Polarity Protection	Integrated	Integrated
Anti-islanding Protection	Integrated	Integrated
AC Overcurrent Protection	Integrated	Integrated
AC Short Circuit Protection	Integrated	Integrated
AC Overvoltage Protection	Integrated	Integrated
DC Switch	Integrated	Integrated
DC Surge Protection	Type II(Type I+II optional)	Type II(Type I+II optional)
AC Surge Protection	Type II	Type II
Rapid Shutdown	Optional	Optional
AFCI	Optional	Optional
Remote Shutdown	Integrated	Integrated
<b>General Data</b>		
Power Factor	0.8 leading ... 0.8 lagging	0.8 leading ... 0.8 lagging
Operating Temperature Range (°C)	-35~+60	-35~+60

<b>Technical Data</b>	<b>GW29.999K-ETA-G20</b>	<b>GW30K-ETA-G20</b>
Operating Environment	Indoor/Outdoor	Indoor/Outdoor
Relative Humidity	0~100%	0~100%
Max. Operating Altitude (m)	4000 (>2000 derating)	4000 (>2000 derating)
Cooling Method	Smart Fan Cooling	Smart Fan Cooling
User Interface	LED, WLAN+APP	LED, WLAN+APP
Communication with BMS	CAN	CAN
Communication	RS485, WiFi+LAN+Bluetooth, 4G+Bluetooth(Optional )	RS485, WiFi+LAN+Bluetooth, 4G+Bluetooth(Optional )
Communication Protocols	Modbus-RTU, Modbus-TCP	Modbus-RTU, Modbus-TCP
Weight (kg)	38	38
Dimension (W×H×D mm)	800*340*270	800*340*270
Noise Emission (dB)	≤45	≤45
Topology	Non-isolated	Non-isolated
Self-consumption at Night (W)	≤10	≤10
Ingress Protection Rating	IP66	IP66
DC Connector	MC4, VACONN Terminal	MC4, VACONN Terminal
AC Connector	VACONN Terminal	VACONN Terminal

Technical Data	GW29.999K-ETA-G20	GW30K-ETA-G20
Environmental Category	4K4H	4K4H
Pollution Degree	III	III
Overvoltage Category	DC II / AC III	DC II / AC III
Protective Class	I	I
Storage Temperature (°C)	-40~+70	-40~+70
The Decisive Voltage Class (DVC)	Battery: C PV: C AC: C Com: A	Battery: C PV: C AC: C Com: A
Mounting Method	Wall/Floor Mounted	Wall/Floor Mounted
Active Anti-islanding Method*8	SMS(Slip-mode frequency) +AFD	SMS(Slip-mode frequency) +AFD
Type of Electrical Supply System	three phase	three phase
Country of Manufacture	China	China
Certification		
Grid Standard	Please refer to the official website	
Safety Regulation		
EMC		

\*1: When the input voltage ranges from 950V to 1000V, the inverter will enter the standby mode, and the voltage returns to 950V to enter the normal operation state.

\*2: Please refer to the user manual for the MPPT Voltage Range at nominal Power.

\*3: According to the local grid regulation.

\*4: GOODWE ESA series has internal bypass 63A passthrough ability to support whole

home backup solution. If the customer don't want to do any breaker upgrade, the main breaker size in GoodWe commissioning APP can be set as previous breaker size.

\*5: GOODWE ESA series has internal bypass 80A passthrough ability to supprt whole home backup solution. If the customer don't want to do any breaker upgrade, the main breaker size in GoodWe commissioning APP can be set as previous breaker size.

\*6: If the backup port is not used, select an appropriate circuit breaker based on the AC maximum output current.

\*7:"Off grid"means the energy of backup output only comes from PV and battery. "On grid"means the energy of the backup output includes the energy from grid or generator(on-grid) side.

\*8: AFDPF: Active Frequency Drift with Positive Feedback

<b>Technical Data</b>	<b>GW5K-BTA-G20</b>	<b>GW6K-BTA-G20</b>	<b>GW8K-BTA-G20</b>	<b>GW9.999K-BTA-G20</b>
Battery Side				
Battery Type	Li-Ion	Li-Ion	Li-Ion	Li-Ion
Nominal Voltage (V)	750	750	750	750
Voltage Range (V)	700-950	700-950	700-950	700-950
Start-up Voltage (V)	720	720	720	720
Number of Battery Inputs	1	1	1	1
Max. Continuous Charging Current (A)	6.7	8.1	10.7	13.4

<b>Technical Data</b>	<b>GW5K-BTA-G20</b>	<b>GW6K-BTA-G20</b>	<b>GW8K-BTA-G20</b>	<b>GW9.999K-BTA-G20</b>
Max. Continuous Discharging Current (A)	7.4	8.9	11.8	14.7
Max. Charging Power (kW)	5	6	8	10
Max. Discharging Power (kW)	5.5	6.6	8.8	11
<b>AC Side (On-Grid)</b>				
Rated Power (kW)	5	6	8	9.999
Max. Power (kW)	5	6	8	9.999
Rated Apparent Power to Grid (kVA)	5	6	8	9.999
Rated Apparent Power from Grid (kVA)	5	6	8	9.999
Max. Apparent Power to Grid (kVA)	5	6	8	9.999
Max. Apparent Power from Grid (kVA)	43.5	43.5	43.5	43.5

<b>Technical Data</b>	<b>GW5K-BTA-G20</b>	<b>GW6K-BTA-G20</b>	<b>GW8K-BTA-G20</b>	<b>GW9.999K-BTA-G20</b>
Nominal Voltage (V)	220/380, 230/400, 3L/N/PE	220/380, 230/400, 3L/N/PE	220/380, 230/400, 3L/N/PE	220/380, 230/400, 3L/N/PE
Voltage Range (V)	180 ~ 260 (According to local standard)	180 ~ 260 (According to local standard)	180 ~ 260 (According to local standard)	180 ~ 260 (According to local standard)
Nominal Frequency (Hz)	50/60	50/60	50/60	50/60
Frequency Range (Hz)	45~55 / 55~65	45~55 / 55~65	45~55 / 55~65	45~55 / 55~65
Rated Current to Grid (A)	7.6 at 380V 7.3 at 400V	9.1 at 380V 8.7 at 400V	12.2 at 380V 11.6 at 400V	15.2 at 380V 14.5 at 400V
Rated Current from Grid (A)	7.6 at 380V 7.3 at 400V	9.1 at 380V 8.7 at 400V	12.2 at 380V 11.6 at 400V	15.2 at 380V 14.5 at 400V
Max. Current to Grid (A)	7.6 at 380V 7.3 at 400V	9.1 at 380V 8.7 at 400V	12.2 at 380V 11.6 at 400V	15.2 at 380V 14.5 at 400V
Max. Current from Grid (A)	63.0	63.0	63.0	63.0
Max. Output Fault Current (Peak and Duration) (A)	46.7@4μs	46.7@4μs	46.7@4μs	74.6@4μs
Inrush Current (Peak and Duration) (A)	21.3@5ms	21.3@5ms	21.3@5ms	25.4@5ms
THDi	<3%	<3%	<3%	<3%

<b>Technical Data</b>	<b>GW5K-BTA-G20</b>	<b>GW6K-BTA-G20</b>	<b>GW8K-BTA-G20</b>	<b>GW9.999K-BTA-G20</b>
Maximum Output Overcurrent Protection (A)	46.7	46.7	46.7	74.6
Type of Voltage	a.c.	a.c.	a.c.	a.c.
<b>Back-up Side</b>				
Rated Output Apparent Power (kVA)	5	6	8	10
Max. Output Apparent Power (kVA)	Off-grid: 5.5 (10.0, 10s), on-grid: 43.5	Off-grid: 6.6(12, 10s), on-grid: 43.5	Off-grid: 8.8 (16.0, 10s), on-grid: 43.5	Off-grid: 11(20.0, 10s), on-grid: 43.5
Nominal Output Voltage (V)	220/380, 230/400, 3L/N/PE	220/380, 230/400, 3L/N/PE	220/380, 230/400, 3L/N/PE	220/380, 230/400, 3L/N/PE
Nominal Output Frequency (Hz)	50/60	50/60	50/60	50/60
Frequency Range (Hz)	45~55 / 55~65	45~55 / 55~65	45~55 / 55~65	45~55 / 55~65
Rated Output Current (A)	7.6 at 380V 7.3 at 400V	9.1 at 380V 8.7 at 400V	12.2 at 380V 11.6 at 400V	15.2 at 380V 14.5 at 400V
Max. Output Current (A) <sup>*3</sup>	Off-grid: 11.4, on-grid: 63	Off-grid: 13.7, on-grid:63	Off-grid: 18.2, on-grid: 63	Off-grid: 22.8, on-grid:63
Max. Output Fault Current (Peak and Duration) (A)	46.7@4μs	46.7@4μs	46.7@4μs	74.6@4μs

<b>Technical Data</b>	<b>GW5K-BTA-G20</b>	<b>GW6K-BTA-G20</b>	<b>GW8K-BTA-G20</b>	<b>GW9.999K-BTA-G20</b>
Inrush Current (Peak and Duration) (A)	21.3@5ms	21.3@5ms	21.3@5ms	25.4@5ms
Maximum Overcurrent Protection (A)	46.7	46.7	46.7	74.6
THDv (@Linear Load)	<3%	<3%	<3%	<3%
On/Off-grid Switching Time (ms)	<4	<4	<4	<4
<b>Efficiency</b>				
Max. Efficiency	98.00%	98.00%	98.00%	98.10%
European Efficiency	96.40%	96.90%	97.10%	97.20%
CEC Efficiency	NA	NA	NA	NA
Max. Battery to AC Efficiency	98.00%	98.00%	98.00%	98.00%
<b>Protection</b>				
Residual Current Monitoring	Integrated	Integrated	Integrated	Integrated
Battery Reverse Polarity Protection	Integrated	Integrated	Integrated	Integrated

<b>Technical Data</b>	<b>GW5K-BTA-G20</b>	<b>GW6K-BTA-G20</b>	<b>GW8K-BTA-G20</b>	<b>GW9.999K-BTA-G20</b>
Anti-islanding Protection	Integrated	Integrated	Integrated	Integrated
AC Overcurrent Protection	Integrated	Integrated	Integrated	Integrated
AC Short Circuit Protection	Integrated	Integrated	Integrated	Integrated
AC Overvoltage Protection	Integrated	Integrated	Integrated	Integrated
AC Surge Protection	Type II	Type II	Type II	Type II
Remote Shutdown	Integrated	Integrated	Integrated	Integrated
<b>General Data</b>				
Power Factor	0.8 leading ... 0.8 lagging	0.8 leading ... 0.8 lagging	0.8 leading ... 0.8 lagging	0.8 leading ... 0.8 lagging
Operating Temperature Range (°C)	-35~+60	-35~+60	-35~+60	-35~+60
Operating Environment	Indoor/Outdoor or	Indoor/Outdoor or	Indoor/Outdoor or	Indoor/Outdoor or
Relative Humidity	0~100%	0~100%	0~100%	0~100%
Max. Operating Altitude (m)	4000 (>2000 derating)	4000 (>2000 derating)	4000 (>2000 derating)	4000 (>2000 derating)

<b>Technical Data</b>	<b>GW5K-BTA-G20</b>	<b>GW6K-BTA-G20</b>	<b>GW8K-BTA-G20</b>	<b>GW9.999K-BTA-G20</b>
Cooling Method	Smart Fan Cooling	Smart Fan Cooling	Smart Fan Cooling	Smart Fan Cooling
User Interface	LED, WLAN+APP	LED, WLAN+APP	LED, WLAN+APP	LED, WLAN+APP
Communication with BMS	CAN	CAN	CAN	CAN
Communication	RS485, WiFi+LAN+Bluetooth, 4G+Bluetooth(Optional)	RS485, WiFi+LAN+Bluetooth, 4G+Bluetooth(Optional)	RS485, WiFi+LAN+Bluetooth, 4G+Bluetooth(Optional)	RS485, WiFi+LAN+Bluetooth, 4G+Bluetooth(Optional)
Communication Protocols	Modbus-RTU, Modbus-TCP	Modbus-RTU, Modbus-TCP	Modbus-RTU, Modbus-TCP	Modbus-RTU, Modbus-TCP
Weight (kg)	30	30	30	30
Dimension (W×H×D mm)	800*340*270	800*340*270	800*340*270	800*340*270
Noise Emission (dB)	≤35	≤35	≤35	≤35
Topology	Non-isolated	Non-isolated	Non-isolated	Non-isolated
Self-consumption at Night (W)	≤10	≤10	≤10	≤10
Conditional Short-circuit Current (A)	6000	6000	6000	6000
Ingress Protection Rating	IP66	IP66	IP66	IP66

<b>Technical Data</b>	<b>GW5K-BTA-G20</b>	<b>GW6K-BTA-G20</b>	<b>GW8K-BTA-G20</b>	<b>GW9.999K-BTA-G20</b>
DC Connector	MC4, VACONN Terminal	MC4, VACONN Terminal	MC4, VACONN Terminal	MC4, VACONN Terminal
AC Connector	VACONN Terminal	VACONN Terminal	VACONN Terminal	VACONN Terminal
Environmental Category	4K4H	4K4H	4K4H	4K4H
Pollution Degree	III	III	III	III
Overvoltage Category	DC II / AC III	DC II / AC III	DC II / AC III	DC II / AC III
Protective Class	I	I	I	I
Storage Temperature (°C)	-40~+70	-40~+70	-40~+70	-40~+70
The Decisive Voltage Class (DVC)	Battery: C	Battery: C	Battery: C	Battery: C
	AC: C	AC: C	AC: C	AC: C
	Com: A	Com: A	Com: A	Com: A
Mounting Method	Wall/Floor Mounted	Wall/Floor Mounted	Wall/Floor Mounted	Wall/Floor Mounted
Active Anti-islanding Method	SMS(Slip-mode frequency) +AFD <sup>*4</sup>	SMS(Slip-mode frequency) +AFD <sup>*4</sup>	SMS(Slip-mode frequency) +AFD <sup>*4</sup>	SMS(Slip-mode frequency) +AFD <sup>*4</sup>
Type of Electrical Supply System	three phase	three phase	three phase	three phase
Country of Manufacture	China	China	China	China

<b>Technical Data</b>	<b>GW5K-BTA-G20</b>	<b>GW6K-BTA-G20</b>	<b>GW8K-BTA-G20</b>	<b>GW9.999K-BTA-G20</b>
Certification				
Grid Standard	Please refer to the official website			
Safety Regulation				
EMC				

<b>Technical Data</b>	<b>GW10K-BTA-G20</b>	<b>GW12K-BTA-G20</b>	<b>GW15K-BTA-G20</b>	<b>GW20K-BTA-G20</b>
Battery Side				
Battery Type	Li-Ion	Li-Ion	Li-Ion	Li-Ion
Nominal Voltage (V)	750	750	750	750
Voltage Range (V)	700-950	700-950	700-950	700-950
Start-up Voltage (V)	720	720	720	720
Number of Battery Inputs	1	1	1	1
Max. Continuous Charging Current (A)	13.4	16.1	20.1	26.7
Max. Continuous Discharging Current (A)	14.7	17.7	22.1	29.4
Max. Charging Power (kW)	10	12	15	20

<b>Technical Data</b>	<b>GW10K-BTA-G20</b>	<b>GW12K-BTA-G20</b>	<b>GW15K-BTA-G20</b>	<b>GW20K-BTA-G20</b>
Max. Discharging Power (kW)	11	13.2	16.5	22
AC Side (On-Grid)				
Rated Power (kW)	10	12	15	20
Max. Power (kW)	10	12	15	20
Rated Apparent Power to Grid (kVA)	10	12	15	20
Rated Apparent Power from Grid (kVA)	10	12	15	20
Max. Apparent Power to Grid (kVA)	10	12	15	20
Max. Apparent Power from Grid (kVA)	43.5	43.5	43.5	43.5
Nominal Voltage (V)	220/380, 230/400, 3L/N/PE	220/380, 230/400, 3L/N/PE	220/380, 230/400, 3L/N/PE	220/380, 230/400, 3L/N/PE
Voltage Range (V)	180 ~ 260 (According to local standard)	180 ~ 260 (According to local standard)	180 ~ 260 (According to local standard)	180 ~ 260 (According to local standard)
Nominal Frequency (Hz)	50/60	50/60	50/60	50/60

<b>Technical Data</b>	<b>GW10K-BTA-G20</b>	<b>GW12K-BTA-G20</b>	<b>GW15K-BTA-G20</b>	<b>GW20K-BTA-G20</b>
Frequency Range (Hz)	45~55 / 55~65	45~55 / 55~65	45~55 / 55~65	45~55 / 55~65
Rated Current to Grid (A)	15.2 at 380V 14.5 at 400V	18.2 at 380V 17.4 at 400V	22.8 at 380V 21.8 at 400V	30.4 at 380V 29.0 at 400V
Rated Current from Grid (A)	15.2 at 380V 14.5 at 400V	18.2 at 380V 17.4 at 400V	22.8 at 380V 21.8 at 400V	30.4 at 380V 29.0 at 400V
Max. Current to Grid (A)	15.2 at 380V 14.5 at 400V	18.2 at 380V 17.4 at 400V	22.8 at 380V 21.8 at 400V	30.4 at 380V 29.0 at 400V
Max. Current from Grid (A)	63.0	63.0	63.0	63.0
Max. Output Fault Current (Peak and Duration) (A)	74.6@4μs	74.6@4μs	83.3@4μs	83.3@4μs
Inrush Current (Peak and Duration) (A)	25.4@5ms	25.4@5ms	29.1@5ms	29.1@5ms
THDi	<3%	<3%	<3%	<3%
Maximum Output Overcurrent Protection (A)	74.6	74.6	83.3	83.3
Type of Voltage	a.c.	a.c.	a.c.	a.c.
<b>Back-up Side</b>				
Rated Output Apparent Power (kVA)	10	12	15	20

<b>Technical Data</b>	<b>GW10K-BTA-G20</b>	<b>GW12K-BTA-G20</b>	<b>GW15K-BTA-G20</b>	<b>GW20K-BTA-G20</b>
Max. Output Apparent Power (kVA)*6	Off-grid: 11(20.0, 10s), on-grid: 43.5	Off-grid: 13.2(24, 10s), on-grid: 43.5	Off-grid: 16.5(30, 10s), on-grid: 43.5	Off-grid: 22(30.0, 10s), on-grid: 43.5
Nominal Output Voltage (V)	220/380, 230/400, 3L/N/PE	220/380, 230/400, 3L/N/PE	220/380, 230/400, 3L/N/PE	220/380, 230/400, 3L/N/PE
Nominal Output Frequency (Hz)	50/60	50/60	50/60	50/60
Frequency Range (Hz)	45~55 / 55~65	45~55 / 55~65	45~55 / 55~65	45~55 / 55~65
Rated Output Current (A)	15.2 at 380V 14.5 at 400V	18.2 at 380V 17.4 at 400V	22.8 at 380V 21.8 at 400V	30.4 at 380V 29.0 at 400V
Max. Output Current (A)*3	Off-grid: 22.8, on-grid: 63	Off-grid: 27.3, on-grid: 63	Off-grid: 33.4, on-grid: 63	Off-grid: 33.4, on-grid: 63
Max. Output Fault Current (Peak and Duration) (A)	74.6@4μs	74.6@4μs	83.3@4μs	83.3@4μs
Inrush Current (Peak and Duration) (A)	25.4@5ms	25.4@5ms	29.1@5ms	29.1@5ms
Maximum Overcurrent Protection (A)	74.6	74.6	83.3	83.3
THDv (@Linear Load)	<3%	<3%	<3%	<3%

<b>Technical Data</b>	<b>GW10K-BTA-G20</b>	<b>GW12K-BTA-G20</b>	<b>GW15K-BTA-G20</b>	<b>GW20K-BTA-G20</b>
On/Off-grid Switching Time (ms)	<4	<4	<4	<4
Efficiency				
Max. Efficiency	98.10%	98.10%	98.10%	98.10%
European Efficiency	97.20%	97.20%	97.30%	97.30%
CEC Efficiency	NA	NA	NA	NA
Max. Battery to AC Efficiency	98.00%	98.00%	98.00%	98.00%
MPPT Efficiency	NA	NA	NA	NA
Protection				
Residual Current Monitoring	Integrated	Integrated	Integrated	Integrated
Battery Reverse Polarity Protection	Integrated	Integrated	Integrated	Integrated
Anti-islanding Protection	Integrated	Integrated	Integrated	Integrated
AC Overcurrent Protection	Integrated	Integrated	Integrated	Integrated

<b>Technical Data</b>	<b>GW10K-BTA-G20</b>	<b>GW12K-BTA-G20</b>	<b>GW15K-BTA-G20</b>	<b>GW20K-BTA-G20</b>
AC Short Circuit Protection	Integrated	Integrated	Integrated	Integrated
AC Overvoltage Protection	Integrated	Integrated	Integrated	Integrated
AC Surge Protection	Type II	Type II	Type II	Type II
Remote Shutdown	Integrated	Integrated	Integrated	Integrated
<b>General Data</b>				
Power Factor	0.8 leading ... 0.8 lagging	0.8 leading ... 0.8 lagging	0.8 leading ... 0.8 lagging	0.8 leading ... 0.8 lagging
Operating Temperature Range (°C)	-35~+60	-35~+60	-35~+60	-35~+60
Operating Environment	Indoor/Outdoor	Indoor/Outdoor	Indoor/Outdoor	Indoor/Outdoor
Relative Humidity	0~100%	0~100%	0~100%	0~100%
Max. Operating Altitude (m)	4000 (>2000 derating)	4000 (>2000 derating)	4000 (>2000 derating)	4000 (>2000 derating)
Cooling Method	Smart Fan Cooling	Smart Fan Cooling	Smart Fan Cooling	Smart Fan Cooling
User Interface	LED, WLAN+APP	LED, WLAN+APP	LED, WLAN+APP	LED, WLAN+APP

<b>Technical Data</b>	<b>GW10K-BTA-G20</b>	<b>GW12K-BTA-G20</b>	<b>GW15K-BTA-G20</b>	<b>GW20K-BTA-G20</b>
Communication with BMS	CAN	CAN	CAN	CAN
Communication	RS485, WiFi+LAN+Bluetooth, 4G+Bluetooth(Optional)	RS485, WiFi+LAN+Bluetooth, 4G+Bluetooth(Optional)	RS485, WiFi+LAN+Bluetooth, 4G+Bluetooth(Optional)	RS485, WiFi+LAN+Bluetooth, 4G+Bluetooth(Optional)
Communication Protocols	Modbus-RTU, Modbus-TCP	Modbus-RTU, Modbus-TCP	Modbus-RTU, Modbus-TCP	Modbus-RTU, Modbus-TCP
Weight (kg)	30	30	30	30
Dimension (W×H×D mm)	800*340*270	800*340*270	800*340*270	800*340*270
Noise Emission (dB)	≤35	≤35	≤40	≤40
Topology	Non-isolated	Non-isolated	Non-isolated	Non-isolated
Self-consumption at Night (W)	≤10	≤10	≤10	≤10
Conditional Short-circuit Current (A)	6000	6000	6000	6000
Ingress Protection Rating	IP66	IP66	IP66	IP66
DC Connector	MC4, VACONN Terminal	MC4, VACONN Terminal	MC4, VACONN Terminal	MC4, VACONN Terminal
AC Connector	VACONN Terminal	VACONN Terminal	VACONN Terminal	VACONN Terminal

<b>Technical Data</b>	<b>GW10K-BTA-G20</b>	<b>GW12K-BTA-G20</b>	<b>GW15K-BTA-G20</b>	<b>GW20K-BTA-G20</b>
Environmental Category	4K4H	4K4H	4K4H	4K4H
Pollution Degree	III	III	III	III
Overvoltage Category	DC II / AC III	DC II / AC III	DC II / AC III	DC II / AC III
Protective Class	I	I	I	I
Storage Temperature (°C)	-40~+70	-40~+70	-40~+70	-40~+70
The Decisive Voltage Class (DVC)	Battery: C	Battery: C	Battery: C	Battery: C
	AC: C	AC: C	AC: C	AC: C
	Com: A	Com: A	Com: A	Com: A
Mounting Method	Wall/Floor Mounted	Wall/Floor Mounted	Wall/Floor Mounted	Wall/Floor Mounted
Active Anti-islanding Method	SMS(Slip-mode frequency) +AFD*4	SMS(Slip-mode frequency) +AFD*4	SMS(Slip-mode frequency) +AFD*4	SMS(Slip-mode frequency) +AFD*4
Type of Electrical Supply System	three phase	three phase	three phase	three phase
Country of Manufacture	China	China	China	China
Certification				
Grid Standard				

Technical Data	GW10K-BTA-G20	GW12K-BTA-G20	GW15K-BTA-G20	GW20K-BTA-G20
Safety Regulation	Please refer to the official website			
EMC				

Technical Data	GW25K-BTA-G20	GW29.999K-BTA-G20	GW30K-BTA-G20
Battery Side			
Battery Type	Li-Ion	Li-Ion	Li-Ion
Nominal Voltage (V)	750	750	750
Voltage Range (V)	700-950	700-950	700-950
Start-up Voltage (V)	720	720	720
Number of Battery Inputs	1	1	1
Max. Continuous Charging Current (A)	33.3	40.0	40.0
Max. Continuous Discharging Current (A)	36.7	44.1	44.1
Max. Charging Power (kW)	25	30	30
Max. Discharging Power (kW)	27.5	33	33
AC Side (On-Grid)			
Rated Power (kW)	25	29.999	30

<b>Technical Data</b>	<b>GW25K-BTA-G20</b>	<b>GW29.999K-BTA-G20</b>	<b>GW30K-BTA-G20</b>
Max. Power (kW)	25	29.999	30
Rated Apparent Power to Grid (kVA)	25	29.999	30
Rated Apparent Power from Grid (kVA)	25	29.999	30
Max. Apparent Power to Grid (kVA)	25	29.999	30
Max. Apparent Power from Grid (kVA)	55.2	55.2	55.2
Nominal Voltage (V)	220/380, 230/400, 3L/N/PE	220/380, 230/400, 3L/N/PE	220/380, 230/400, 3L/N/PE
Voltage Range (V)	180 ~ 260 (According to local standard)	180 ~ 260 (According to local standard)	180 ~ 260 (According to local standard)
Nominal Frequency (Hz)	50/60	50/60	50/60
Frequency Range (Hz)	45~55 / 55~65	45~55 / 55~65	45~55 / 55~65
Rated Current to Grid (A)	37.9 at 380V 36.3 at 400V	45.5 at 380V 43.5 at 400V	45.5 at 380V 43.5 at 400V
Rated Current from Grid (A)	37.9 at 380V 36.3 at 400V	45.5 at 380V 43.5 at 400V	45.5 at 380V 43.5 at 400V
Max. Current to Grid (A)	37.9 at 380V 36.3 at 400V	45.5 at 380V 43.5 at 400V	45.5 at 380V 43.5 at 400V
Max. Current from Grid (A)	80.0	80.0	80.0

Technical Data	GW25K-BTA-G20	GW29.999K-BTA-G20	GW30K-BTA-G20
Max. Output Fault Current (Peak and Duration) (A)	125@4 $\mu$ s	125@4 $\mu$ s	125@4 $\mu$ s
Inrush Current (Peak and Duration) (A)	32.3@5ms	32.3@5ms	32.3@5ms
THDi	<3%	<3%	<3%
Maximum Output Overcurrent Protection (A)	125	125	125
Type of Voltage	a.c.	a.c.	a.c.
Back-up Side			
Rated Output Apparent Power (kVA)	25	30	30
Max. Output Apparent Power (kVA)*6	Off-grid: 27.5(45.0, 10s), on-grid: 55.2	Off-grid: 33(45.0, 10s), on-grid: 55.2	Off-grid: 33(45.0, 10s), on-grid: 55.2
Nominal Output Voltage (V)	220/380, 230/400, 3L/N/PE	220/380, 230/400, 3L/N/PE	220/380, 230/400, 3L/N/PE
Nominal Output Frequency (Hz)	50/60	50/60	50/60
Frequency Range (Hz)	45~55 / 55~65	45~55 / 55~65	45~55 / 55~65
Rated Output Current (A)	37.9 at 380V 36.3 at 400V	45.5 at 380V 43.5 at 400V	45.5 at 380V 43.5 at 400V
Max. Output Current (A)*3	Off-grid: 50.0, on-grid: 80	Off-grid: 50.0, on-grid: 80	Off-grid: 50.0, on-grid: 80

<b>Technical Data</b>	<b>GW25K-BTA-G20</b>	<b>GW29.999K-BTA-G20</b>	<b>GW30K-BTA-G20</b>
Max. Output Fault Current (Peak and Duration) (A)	125@4 $\mu$ s	125@4 $\mu$ s	125@4 $\mu$ s
Inrush Current (Peak and Duration) (A)	32.3@5ms	32.3@5ms	32.3@5ms
Maximum Overcurrent Protection (A)	125	125	125
THDv (@Linear Load)	<3%	<3%	<3%
On/Off-grid Switching Time (ms)	<4	<4	<4
<b>Efficiency</b>			
Max. Efficiency	98.20%	98.20%	98.20%
European Efficiency	97.40%	97.40%	97.40%
CEC Efficiency	NA	NA	NA
Max. Battery to AC Efficiency	98.00%	98.00%	98.00%
<b>Protection</b>			
Residual Current Monitoring	Integrated	Integrated	Integrated
Battery Reverse Polarity Protection	Integrated	Integrated	Integrated
Anti-islanding Protection	Integrated	Integrated	Integrated

<b>Technical Data</b>	<b>GW25K-BTA-G20</b>	<b>GW29.999K-BTA-G20</b>	<b>GW30K-BTA-G20</b>
AC Overcurrent Protection	Integrated	Integrated	Integrated
AC Short Circuit Protection	Integrated	Integrated	Integrated
AC Overvoltage Protection	Integrated	Integrated	Integrated
AC Surge Protection	Type II	Type II	Type II
Remote Shutdown	Integrated	Integrated	Integrated
<b>General Data</b>			
Power Factor	0.8 leading ... 0.8 lagging	0.8 leading ... 0.8 lagging	0.8 leading ... 0.8 lagging
Operating Temperature Range (°C)	-35~+60	-35~+60	-35~+60
Operating Environment	Indoor/Outdoor	Indoor/Outdoor	Indoor/Outdoor
Relative Humidity	0~100%	0~100%	0~100%
Max. Operating Altitude (m)	4000 (>2000 derating)	4000 (>2000 derating)	4000 (>2000 derating)
Cooling Method	Smart Fan Cooling	Smart Fan Cooling	Smart Fan Cooling
User Interface	LED, WLAN+APP	LED, WLAN+APP	LED, WLAN+APP
Communication with BMS	CAN	CAN	CAN

Technical Data	GW25K-BTA-G20	GW29.999K-BTA-G20	GW30K-BTA-G20
Communication	RS485, WiFi+LAN+Bluetooth, 4G+Bluetooth(Optional)	RS485, WiFi+LAN+Bluetooth, 4G+Bluetooth(Optional)	RS485, WiFi+LAN+Bluetooth, 4G+Bluetooth(Optional)
Communication Protocols	Modbus-RTU, Modbus-TCP	Modbus-RTU, Modbus-TCP	Modbus-RTU, Modbus-TCP
Weight (kg)	32	32	32
Dimension (W×H×D mm)	800*340*270	800*340*270	800*340*270
Noise Emission (dB)	≤45	≤45	≤45
Topology	Non-isolated	Non-isolated	Non-isolated
Self-consumption at Night (W)	≤10	≤10	≤10
Conditional Short-circuit Current (A)	6000	6000	6000
Ingress Protection Rating	IP66	IP66	IP66
DC Connector	MC4, VACONN Terminal	MC4, VACONN Terminal	MC4, VACONN Terminal
AC Connector	VACONN Terminal	VACONN Terminal	VACONN Terminal
Environmental Category	4K4H	4K4H	4K4H
Pollution Degree	IV	IV	IV
Overvoltage Category	DC II / AC III	DC II / AC III	DC II / AC III

Technical Data	GW25K-BTA-G20	GW29.999K-BTA-G20	GW30K-BTA-G20
Protective Class	I	I	I
Storage Temperature (°C)	-40~+70	-40~+70	-40~+70
The Decisive Voltage Class (DVC)	Battery: C	Battery: C	Battery: C
	AC: C	AC: C	AC: C
	Com: A	Com: A	Com: A
Mounting Method	Wall/Floor Mounted	Wall/Floor Mounted	Wall/Floor Mounted
Active Anti-islanding Method	SMS(Slip-mode frequency) +AFD <sup>*4</sup>	SMS(Slip-mode frequency) +AFD <sup>*4</sup>	SMS(Slip-mode frequency) +AFD <sup>*4</sup>
Type of Electrical Supply System	three phase	three phase	three phase
Country of Manufacture	China	China	China
Certification			
Grid Standard	Please refer to the official website		
Safety Regulation			
EMC			

\*1: When the input voltage ranges from 950V to 1000V, the inverter will enter the standby mode, and the voltage returns to 950V to enter the normal operation state.

\*2: Please refer to the user manual for the MPPT Voltage Range at nominal Power.

\*3: The Max. Output Current in off-grid operation accounts for a three-phase maximum 150% unbalanced capability.

\*4: AFDPF: Active Frequency Drift with Positive Feedback, AQDPF: Active Q Drift with Positive Feedback.

## 9.2 Battery Technical Data

Technical Data	GW5.1-BAT-D-G20	GW8.3-BAT-D-G20	GW5.1-BAT-D-G21	GW8.3-BAT-D-G21
Rated Energy (kWh)	5.12	8.32	5.12	8.32
Usable Energy (kWh)*1	5	8	5	8
Battery Type	LFP (LiFePO <sub>4</sub> )			
Operating Voltage Range (V) (single phase system)	350~550			
Operating Voltage Range (V) (three phase system)	700~950			
Max. Input Current (System) (A)	12	19	12	19
Max. Output Current (System) (A)	13.2	21	13.2	21
Max. Input Power (System) (kW)*2	5	8	5	8
Max. Output Power (System) (kW)*2	5	8	5	8
Peak.Output Power (System) (kW)*2	7.5 @10s	12 @10s	7.5 @10s	12 @10s
Charging Temperature Range (°C)	-18~55		2~55	
Discharging Temperature Range (°C)	-20~55		-20~55	
Relative Humidity	5-95%			
Max. Operating Altitude (m)	4000			

Technical Data		GW5.1-BAT-D-G20	GW8.3-BAT-D-G20	GW5.1-BAT-D-G21	GW8.3-BAT-D-G21
Noise Emission (dB)		≤29			
Communication		CAN			
Weight (kg)		57.5±1	79±1	57.5±1	79±1
Dimensions (W×H×D mm)		800*326*270			
Optional Function Configuration		heating		/	
Ingress Protection		IP66			
Storage Temperature (°C)		-20 ~55			
Max. Storage time		12 months (-20°C~35°C)			
		6 months (35°C~45°C)			
Scalability		6 pcs			
Mounting Method		Floor stacked / Wall-mounted			
Cycle Life		≥6000 (25±2°C, 0.5C, 90%DOD, 70%EOL)			
Country of Manufacture		China			
Standard and Certification	Safety	IEC62619, IEC60730, EN62477, IEC63056, IEC62040, CE, CEC, VDE2510			
	EMC	CE, RCM			
	Transportation	UN38.3 ADR			

Technical Data		GW6.0-BAT-D-G20	GW9.0-BAT-D-G20
Battery Type		LFP (LiFePO4)	
Rated Capacity (Ah)		314Ah	
Rated Energy (kWh)		6	9

<b>Technical Data</b>	<b>GW6.0-BAT-D-G20</b>	<b>GW9.0-BAT-D-G20</b>
Usable Energy (kWh) <sup>*1</sup>	5.9	8.85
Nominal Voltage(V) (Battery)	19.2	28.8
Voltage Range(V) (Battery)	16.2~21.9	24.3~32.8
Operating Voltage Range (V) (single phase system)	350~550	
Operating Voltage Range (V) (three phase system)	700~950	
Max. Input Current (System) (A)	7.1	10.7
Max. Output Current (System) (A)	7.9	11.8
Max. Input Power (System) (kW) <sup>*2</sup>	3	4.5
Max. Output Power (System) (kW) <sup>*2</sup>	3	4.5
Peak Output Power (System) (kW) <sup>*2</sup>	4.5 (10s)	6.75 (10s)
Charging Temperature Range(°C)	-20~55	
Discharging Temperature Range (°C)	-20~55	
Relative Humidity	4-100%	
Max. Operating Altitude (m)	4000	
Noise Emission (dB)	≤27	
Communication	CAN&485	
Weight (kg)	61±1kg	77±1kg
Useable Extinguishing Agent	CO2, H2O	
Crucial Material	LiFePO4, C, Cu, LiPF6, Al, (C3H6)n	
Ingress Protection	IP66	
Protective Class	I	
Dimensions (W×H×D mm)	800*326*270	

Technical Data		GW6.0-BAT-D-G20	GW9.0-BAT-D-G20
Function Configuration		Heating (Integrated); Aerosol fire extinguishing (Integrated)	
Storage Temperature (°C)		-20 ~55	
Max. Storage time		12 months (-20°C~35°C) 6 months (35°C~45°C)	
Scalability*3		12P	
Mounting Method		Floor stacked / Wall-mounted / Grounded	
Cycle Life		≥6000 (25±2°C 0.5C 90%DOD 70%EOL )	
Country of Manufacture		China	
Standard and Certification	Safety	IEC62619, IEC60730, EN62477, IEC63056, IEC62040, CE, CEC, Regulation 2023/1542 , VDE2510-50	
	EMC	CE, RCM	
	Transportation	UN38.3 ADR	

\*1: Test conditions, 100% DOD (cell 2.85~3.6V voltage range), 0.2P charge & discharge at 25±2 °C for battery system at the beginning of life. Usable energy is defined by its initial design value. Actual available energy may vary depending on charge/discharge rate, environmental conditions (e.g. temperature), transport and storage factors.

\*2: Max. Input Power /Max. Output Power/Peak.Output Power derating will occur related to Temperature and SOC.

\*3 For single-column stacked installations, the maximum number of parallel units is 6.

## 9.3 Smart Meter Technical Data

### 9.3.1 GM330

model	GM330
Measurement Range	

<b>model</b>	<b>GM330</b>
Supported Grid Types	1P2W/3P3W/3P4W
Operating voltage (Vac)*	3P4W: 100~472 L-N 3P3W: 100~472 L-L
Frequency (Hz)	50/60
CT ratio	nA: 5A
<b>Accuracy Parameters</b>	
voltage/current	Class 0.5
Active Energy	Class 0.5
Reactive Energy	Class 1
<b>Communication Parameters</b>	
Communication Method	RS485
Communication Distance (m)	1000
<b>General Parameters</b>	
Dimensions (W*H*D mm)	72*85*72
Housing	4-module
Weight (g)	240
Mounting Method	DIN Rail
User Interface	4 LEDs, Reset Button
Power Consumption (W)	< 5
<b>Environmental Parameters</b>	
IP Rating	IP20
Operating Temperature Range (°C)	-30-+70

<b>model</b>	<b>GM330</b>
Storage Temperature Range (°C)	-30+70
Relative Humidity (non-condensing)	0-95%
Max. Operating Altitude (m)	3000

\*Supports 1.1 times voltage access.

\*The standard CT for the meter has been uniformly updated to the 120A:40mA specification. Meters equipped with the 200A:50mA specification CT will no longer be sold after June 2026.

### 9.3.2 GMK330

<b>model</b>	<b>GMK330</b>
<b>Measurement Range</b>	
Supported Grid Types	1P2W/3P3W/3P4W
Operating voltage (Vac)*	3P4W: 90~264 L-N 3P3W: 90~264 L-L
Frequency (Hz)	50/60
CT ratio	120A: 40mA 200A: 50mA*
Number of CTs	3
<b>Accuracy Parameters</b>	
voltage/current	Class 0.5
Active Energy	Class 0.5
Reactive Energy	Class 1
<b>Communication Parameters</b>	
Communication Method	RS485

<b>model</b>	<b>GMK330</b>
Communication Distance (m)	1000
<b>General Parameters</b>	
Dimensions (W*H*D mm)	72*85*72
Housing	4-module
Weight (g)	240
Mounting Method	DIN Rail
User Interface	4 LEDs, Reset Button
Power Consumption (W)	< 5
<b>Environmental Parameters</b>	
IP Rating	IP20
Operating Temperature Range (°C)	-30+70
Storage Temperature Range (°C)	-30+70
Relative Humidity (non-condensing)	0-95%
Max. Operating Altitude (m)	3000

\*Supports 1.1 times rated voltage connection.

\*The standard CT for the meter has been uniformly changed to the 120A:40mA specification. Meters equipped with CTs of the 200A:50mA specification will no longer be sold after June 2026.

## 9.4 Smart Dongle Technical Data

### 9.4.1 WiFi/LAN Kit-20

technical parameter		WiFi/LAN Kit-20
Output Voltage (V)		5
Power Consumption (W)		≤2
Communication Interface		USB
Communication Parameters	Ethernet	10M/100Mbps Auto-negotiation
	Wireless	IEEE 802.11 b/g/n @2.4 GHz
	Bluetooth	Bluetooth V4.2 BR/EDR and Bluetooth LE Standard
Mechanical Parameters	Dimensions (W×H×D mm)	48.3*159.5*32.1
	Weight (g)	82
	Ingress Protection Rating	IP65
	Mounting Method	USB Port Plug and Play
Operating Temperature Range (°C)		-30~+60
Storage Temperature Range (°C)		-40~+70
Relative Humidity		0-95%
Max. Operating Altitude (m)		4000

#### 9.4.2 4G Kit-G20

Product Model	4G Kit-G20
Device Management	
Maximum Supported Inverter Quantity	1
Power Parameters	
Input Voltage (V)	5
Power Consumption (W)	≤5
Interface Method	USB
Communication Parameters	
4G/3G/2G	LTE-FDD: B1/2/3/4/5/7/8/12/13/18/19/20/25/26/28/66 LTE-TDD: B34/38/39/40/41 WCDMA: B1/2/4/5/6/8/19 GSM/EDGE: B2/3/5/8
GNSS Positioning	/
Bluetooth	Bluetooth V5.0

<b>Product Model</b>	<b>4G Kit-G20</b>
<b>Mechanical Parameters</b>	
Dimensions (Width × Height × Thickness mm)	48.3*328*32.3 (Including external antenna)
Weight (g)	100 (Including external antenna)
indicator	LED* 2
Mounting Method	Plug and Play
SIM Card Size	Micro sim, 15mm*12mm
<b>Environmental Parameters</b>	
Operating Temperature Range (°C)	-30~+65
Storage Temperature Range (°C)	-40~+70
Relative Humidity	0-100%
IP Rating	IP66
Max. Operating Altitude (m)	4000
<b>Standards Met</b>	
Certification	CE-RED (EN18031), RCM

# 10 Appendix

## 10.1 FAQ

### 10.1.1 How to conduct auxiliary detection for smart meters/CT?

The meter detection function can detect whether the meter CT is connected correctly and the current operating status of the meter and CT.

1. Navigate to the detection page via **[Home]** > **[Settings]** > **[Meter/CT Auxiliary Detection]**.
2. Click Start Detection, wait for the detection to complete, and then view the detection results.

### 10.1.2 How to Upgrade the Device Version

Through firmware information, you can view or upgrade:

The inverter's DSP version, ARM version, communication module software version, battery's BMS version, DCDC version, etc.

- **Prompt Upgrade:**

When the user opens the App, an upgrade prompt pops up on the home page. The user can choose whether to upgrade. If they choose to upgrade, they can complete the upgrade by following the on-screen instructions.

- **Regular Upgrade:**

Go to **[Home]** > **[Settings]** > **[Firmware Information]** to enter the firmware information viewing interface.

Click "Check for Updates". If a new version is available, complete the upgrade by following the on-screen instructions.

- **Forced Upgrade:**

The App pushes upgrade information. The user must upgrade according to the prompts; otherwise, the App cannot be used. Complete the upgrade by following the

on-screen instructions.

## Inverter Software Version Upgrade

- The inverter supports software upgrade via a USB drive.
- Before using a USB drive to upgrade the device, please contact the after-sales service center to obtain the software upgrade package and upgrade method.

## 10.2 Explanation of Terms

- **Definition of Overvoltage Categories**
  - **Overvoltage Category I:** Equipment connected to circuits where measures are taken to limit transient overvoltages to a suitably low level.
  - **Overvoltage Category II:** Energy-consuming equipment supplied from a fixed electrical installation. This category includes appliances, portable tools, and other household and similar loads. If special requirements for reliability and suitability of such equipment exist, Overvoltage Category III applies.
  - **Overvoltage Category III:** Equipment in fixed electrical installations where special requirements for reliability and suitability must be met. This includes switching devices in fixed installations and industrial equipment permanently connected to fixed electrical installations.
  - **Overvoltage Category IV:** Equipment used at the origin of the electrical installation. This includes meters and primary overcurrent protection devices, etc.
- **Definition of Damp Location Categories**

Environmental Parameters	Level		
	3K3	4K2	4K4H
Temperature Range	0~+40°C	-33~+40°C	-33~+40°C
Humidity Range	5% to 85%	15% to 100%	4% to 100%

- **Definition of Environmental Categories:**
  - **Outdoor Inverter:** Ambient air temperature range from -25°C to +60°C, suitable for Pollution Degree 3 environments.
  - **Indoor Type II Inverter:** Ambient air temperature range from -25°C to +40°C, suitable for Pollution Degree 3 environments.
  - **Indoor Type I Inverter:** Ambient air temperature range from 0°C to +40°C,

suitable for Pollution Degree 2 environments.

• **Definition of Pollution Degree Categories**

- **Pollution Degree 1:** No pollution or only dry, non-conductive pollution.
- **Pollution Degree 2:** Normally only non-conductive pollution occurs. Temporary conductivity caused by condensation must be expected occasionally.
- **Pollution Degree 3:** Conductive pollution occurs, or dry non-conductive pollution becomes conductive due to condensation.
- **Pollution Degree 4:** Persistent conductive pollution occurs, for example, due to conductive dust, rain, or snow.

### 10.3 Battery SN Code Meaning



The 11th-14th digits

LXD10DSC0002

The 11th to 14th digits of the product SN code represent the production time code. The production date in the above image is 2023-08-08

- The 11th and 12th digits are the last two digits of the production year, e.g., 2023 is represented as 23;
- The 13th digit is the production month, e.g., August is represented as 8; Details are as follows:

Month	Jan-Sep	Oct	Nov	Dec
Month Code	1~9	A	B	C

- The 14th digit is the production date, e.g., the 8th day is represented as 8; Numbers are preferred for representation, e.g., 1~9 represent the 1st to 9th days, A represents the 10th day, and so on. Among them, the letters I and O are not used to avoid confusion. Details are as follows:

Production Day	1	2	3	4	5	6	7	8	9

Code	1	2	3	4	5	6	7	8	9
------	---	---	---	---	---	---	---	---	---

Production Date	10	11	12	13	14	15	16	17	18
-----------------	----	----	----	----	----	----	----	----	----

Code	A	B	C	D	E	F	G	H	J
------	---	---	---	---	---	---	---	---	---

Production Date	21	22	23	24	25	26	27	28	29
-----------------	----	----	----	----	----	----	----	----	----

Code	M	N	P	Q	R	S	T	U	V
------	---	---	---	---	---	---	---	---	---

# 11 Contact Information

GoodWe Technologies Co., Ltd.  
90 Zijin Road, Suzhou New District, China  
400-998-1212  
[www.goodwe.com](http://www.goodwe.com)  
[service@goodwe.com](mailto:service@goodwe.com)